



Local Loop and Radio Electronics

Kathi Covert

Dean Shell

Revised Edition: 2014

ISBN 978-81-323-0946-8

© All rights reserved.

Published by:
Academic Studio
4735/22 Prakashdeep Bldg,
Ansari Road, Darya Ganj,
Delhi - 110002
Email: info@wtbooks.com

Table of Contents

Chapter 1 - CT2 and Fiber to the Telecom Enclosure

Chapter 2 - Fiber to the X

Chapter 3 - Last Mile

Chapter 4 - 110 Block and 66 Block

Chapter 5 - Demarcation Point

Chapter 6 - Digital Loop Carrier and Ethernet over Twisted Pair

Chapter 7 - Leased Line

Chapter 8 - Local-Loop Unbundling

Chapter 9 - Network Interface Device

Chapter 10 - Next Generation Access, Party Line (Telephony) and Remote Concentrator

Chapter 11 - RF Connector

Chapter 12 - Electronic Filter

Chapter 13 - Transmission Line

Chapter 14 - Voltage-Controlled Oscillator

Chapter 15 - Electronic Amplifier

Chapter 16 - Transmitter

Chapter 17 - Antenna

Chapter 18 - Receiver (Radio)

Chapter 19 - Detector

Chapter 1

CT2 and Fiber to the Telecom Enclosure

CT2

CT2 is a cordless telephony standard that was used in the early 1990s to provide short-range proto-mobile phone service in some countries in Europe. It is considered the precursor to the popular DECT system. CT2 is frequently referred to by the marketing name "Telepoint."

Overview

CT2 is a digital FDMA system that uses Time Division Duplexing technology to share carrier frequencies between handsets and base stations. Features of the system are:

- Standardized on 864-868 MHz
- 500 frames/second (alternately base station and handset)
- 100 kHz carriers
- 32 kbit/s ADPCM voice channel compression
- 10 mW maximum power output
- GFSK data encoding
- Up to 100 meter (300 ft) range

Unlike DECT, CT2 was a voice-only system, though like any minimally-compressed voice system, users could deploy analog modems to transfer data. In the early nineties, Apple Computer sold a CT2 modem called the PowerBop to make use of France's Bibop CT2 network. Although CT2 is a microcellular system, fully capable of supporting handoff, unlike DECT it does not support "forward handoff", meaning that it has to drop its former radio link before establishing the subsequent one, leading to a sub-second dropout in the call during the handover.

Deployment and usage



CT2 Rabbit Telephone

PHONE WARS

DIAL 'M' FOR MONEY

The mad dash to build the first mobile phone for everyone has set the adrenaline flowing in technical and marketing man alike. But what was once a one-horse race may well end in a photo finish.



The twisted brains are already calling it a techno-quip, a mixture of communications breakthrough, the ultimate yuppie toy, a British invention to change the world. In fact it's a phone. A new sort of phone, of course, but not a phone you can, as yet, actually make calls with. Not a phone that costs cheap (estimated retail: £200-£300). And not even a phone that you can use anywhere you want.

But talk to the coiled people who designed this thing just outside Cambridge, or talk to its fans over, and it's the discovery of penicillin all over again. They're mad here because they have the five classic ingredients for perfect consumer technology in the late 80s. It's a useful money-making product; it has a sleek, cool appearance; it will ride a wave of surefire marketing hype; it has attracted the funds needed to research, develop, manufacture and launch; and it will plug a gap in a potentially huge market.

That was a gap in the market 20 years ago, when it was in Leicester Square and a cover picture of Dylan — people liked themselves more for not getting there first. The gap that this phone fills — let's call the phone Persephone, because that's the name its engineers gave it — is between the domestic cordless (retail starts at £100), and the prototype cellular phone (retail maybe £1,800). The pros are quoted because they're a major part of the sales pitch; other key factors are speech quality, convenience and accessibility. The new Persephone hopes to have all its rivals comprehensively licked when it arrives on our High Streets at the end of the year.

The Future

The prototype I tried in the lab worked for a bit, but only one way. The engineer in the other room talked to me, but I couldn't talk back because something in the sky, grey, beautifully designed machine was poorly connected. This was the future of communication technology? One-way is clearly no good. I can get that sort of communication from my satellite radio.

"Relax," they told me. "It is the future!" Persephone is a second generation cordless phone. It can be used in those areas: home, office and public places. At home and in the office it replaces the phone cord by using a radio link between the handset and the base station. The base station being connected to the national Telecom system through the standard phone socket. At home you can each have your own handset and dial out on the same base station. At work an entire payroll can use the handsets as they would ordinary phones, wherever they are in the office/factory. For the public area — the sportsground, the lift station, the railway service station, the shopping centre, the airport — will serve as Persephone's sales clincher. Providing you stay within 100-200 metres of the proposed Persephone's essentially public base stations send high on calls, you'll be able to dial out using the same handset you use at home or at work. In all cases you'll be billed later at roughly the cost of a payphone call; it is, in a sense, a permanent portable payphone with no jammed coin slots.

Persephone's advantages over a cellular phone are clear. You'd buy the hardware and make the calls at respectively one-third and one-half of the cost; you'd be able to carry it without the aid of a trunk and, thanks to the digital technology, you'd get clearer speech quality with no annoying power loss phones. No more frequency effects, says one Persephone engineer. Other plus points include increased security and the obvious advantage of being able to use it outside the confines of your back garden.

We'll tackle its position in a moment, but at this point, maybe you're thinking, well, if this is such a breakthrough, and if these Persephones stand to make so much money, then how come no one except this one company near Cambridge — PA Technology — is in, on the act? Actually there are others. British Telecom is there working on it, as is Stone Communications, a firm linked with ubiquitous radio Sir Clive Sinclair. Yes, there are mobile phone users, and this the ones between BT and MIRA. (Persephone for the cellular market. The Cambridge PA people are funded as their research by our own giant Ferranti, and slowly think victory is almost theirs. Over lunch an engineer lets slip that he'll be terribly disappointed if they're beaten to the market by anyone. This seems to be a blatant underestimation. If BT or Shave gets there first, sets its own standards and stakes out the first big market slice, it may not only cost Ferranti several millions (it'll get over that) but it may signal to the engineers that it's time to look for other, but in other fields, in other parts of the world. The only catchword, says one engineer, "would come from going to Dallas and opening up someone else's phone and finding out how the hell they did it."

Military Lasers

The commercial phone appears a strange product for Ferranti to support. A British firm known principally for its defence and computer systems, employing more than 20,000 staff and boasting annual sales in excess of \$1.5 billion, it could claim credit for state-of-the-art and unusual, non-sights, unique military lasers, air and road traffic control systems, and break-through in advanced submarine platform control.

In 1982 it applied, unsuccessfully, for a licence to operate a cellular network (the Saxons went to Gifford and Kierulff) and retained a vision of portable communications for the traveller — a vision strengthened by the realisation that cellular licences were virtually licences to print money. The vision belonged principally to technical director John Pickin, and it was Pickin who forged the link with PA Technology, funding a three-year feasibility study.

PA had previously looked into a similar system, also involving a public base station, for Kierulff and now kept at the drawing board. In early 1987 PA produced its first complete demonstration model for which users had to carry the necessary electronics in rucksacks on their backs. It was enough to win PA the development contract, and enough for Ferranti to commit itself to a new start-up company. Li-bera, to advance the proper further. Li-bera was obviously set up to bring in City finance and expertise, but unofficially confirmed that Ferranti believed the phone too speculative a venture to go it alone. The City provided some £2.5 million (three quarters of the cost so far). One PA engineer recalls how the investors "were like little children — they'd never seen anything like it. They could walk around, and talk to each other on it, and it had no wires. It blew their minds at the time."

What happened then is the stuff of all the best science and technology discovery stories — the endless sleepless nights. PA's knowledge office is only a 15-minute drive from Cambridge's colleges and The Rocks, but a 30-minute away in traffic. Designed by Richard Rogers, the building has a low ceiling, so much as a series of interlocking heavy Perspex tubes on a grid, an elongated open-plan shell of metal function — gal-pony, laminated worktops and shelves arranged in circles, lit from lights and a constant hum of air conditioning that could, if required, speed. In the glow, the workforce is hours. There are also pot plants that say: Yes, there is some real natural life out there, and because you won't see it yourself for the next few months, here's a cut-out or two to remind you. The labs in this building are dogmatically cluttered with hundreds of thousands of pounds worth of testing and measuring equipment, along with keyboards, soldering irons, heat-



The Zone Phone from Ferranti International

BY SIMON GARFIELD

Ferranti ZonePhone

CT2 was deployed in a number of countries, including Britain and France. In Britain, the Ferranti Phonezone system was the first public network to go live in 1989, and the much larger Rabbit network operated from 1992 to 1993. In France, the Bibop network ran from 1991 to 1995. In Finland, Pointer service was available for a short time on the 1980s before being overridden by NMT. Outside of Europe, the system achieved a certain amount of popularity in Hong Kong with three operators offering service until licenses were terminated in 1996. Since 31 December 2008, CTA1 and CTA2 based phones are forbidden in Germany.

Typical CT2 users were sold a handset and base station which they could connect to their own home telephone system. Calls via the home base station would be routed via the

home telephone line and in this configuration, the system was identical to a standard cordless phone. When in range, the user could receive incoming calls.

Once out of range of the home, the CT2 user could find signs indicating a network base station in the area, and make outgoing calls (but not receive calls) using the network base station. Base stations were located in a variety of places, including high-streets and other shopping areas, gas stations, and transportation hubs such as rail stations. In this configuration, callers would be charged a per-minute rate higher than if they made calls from home, but not as high as conventional cellular charges.

The advantages to the user were that the rates were generally lower than cellular, and that the same handset could be used at home and away from home. The disadvantages, compared to cellular, were that many networks did not deliver incoming calls to the phones (Bibop was a notable exception), and that their areas of use were more limited.

There are no known open CT2 networks still running, though CT2 phones are still used by some as cordless phones.

Similar systems

Japan's Personal Handyphone System, another system based upon microcells, is a direct analog of CT2 and has achieved a much greater level of success. PHS is a full microcellular system, with hand-off, with better range and more features.

The DECT system is CT2's successor, and also supports full microcellular service and data. However, to date DECT has been used to provide commercial mobile-phone like service only in Italy in 1997-8 (the FIDO network).

In the US, a system similar to DECT and PHS called PACS was developed but never deployed commercially.

CT-2, as used in Europe and Hong Kong, required adherence to the MPT 1322 and MPT 1334 technical standards. Most striking was the use of TDD (Time division duplex) channels where only one radio channel was used to carry both sides of a duplex telephone conversation. This solved the problem of different propagation paths between two widely separated channels (up to 45 Mhz in some cellular systems), but also placed an upper limit on the range of CT-2 signaling, since the speed of light (and radio signals) prevented long transmission paths. However, the use of TDD made available many frequency bands for CT-2 use, since a "paired" return path was not needed.

An American company, Cellular 21, Inc. (later to become Advanced Cordless Technologies, Inc.) headed by broadcaster Matt Edwards, petitioned the FCC to permit the use of CT-2 technology in the US. ACT built two active test systems which were located in Monticello, NY (outdoor), and outside and inside the South Street Seaport complex in lower Manhattan. The Monticello public field trials used the Timex technology which was incompatible with the trans-European standard, while the South

Street Seaport indoor test used equipment from Ferranti, GPT, and Motorola, which at the time manufactured CT-2 equipment for Singapore and Hong Kong markets. GPT and Motorola both provided CT-2 equipment for the Rabbit system rollout in France (GPT handset and charger shown above). All the testing was under an FCC Experimental license. The ACT/Cellular 21 "Petition for Rulemaking" (RM-7152), along with a later petition by Millicom, became the basis of the FCC's PCS initiative (FCC GEN Docket 90-314) which resulted in the allocation of frequencies in the 1.7 to 2.1 Ghz band as spectrum expansion for the crowded 800 Mhz cellular band. The FCC used the acronym PCS to designate Personal Communications Services, separate and distinct from cellular service which was 800 MHz analog at the time. PCS was to be digital-only, and has progressed through several "generations" (mostly marketing designations) such as G3 and G4.

Fiber to the telecom enclosure

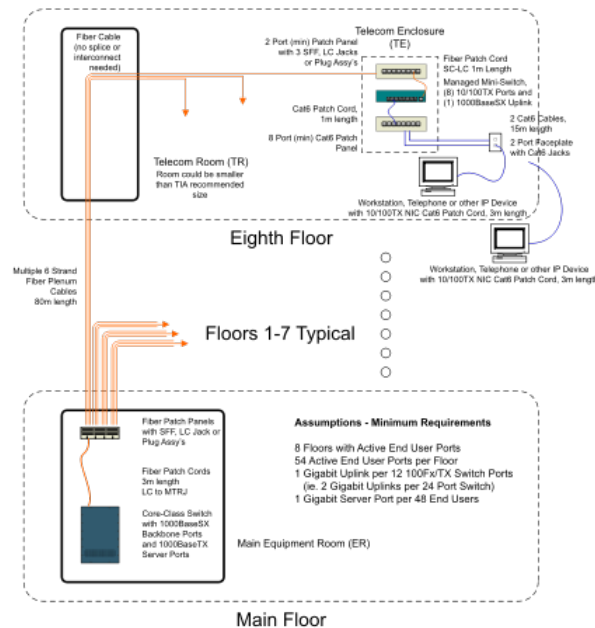

Diagram originally published by the Fiber Optics LAN Section of the Telecommunications Industry Association

Fiber to the telecom enclosure (FTTE), also sometimes called **fiber to the zone (FTTZ)**, is a standards-compliant structured cabling system architecture that extends the optical fiber backbone network from the equipment room, through the telecom room, and directly to a telecommunications enclosure (TE) installed in a common space to serve a

number of users in a work area. Its implementation is based on the TIA/EIA-569-B “Pathways and Spaces” standard, which defines the Telecommunications Enclosure (TE), and TIA/EIA-568-B.1 Addendum 5, which defines the cabling when a TE is used. The FTTE architecture allows for many media choices from the TE to the work area; it may be balanced twisted pair copper, multi-mode optical fiber, or even wireless if an access point is installed in or near the TE.

Depending on the user’s needs, FTTE can be deployed in low-density or high-density configurations. A low-density system might use one or two inexpensive 8-port Ethernet mini-switches as an example (these switches have eight 10/100 Mbit/s Ethernet copper ports and one 1 Gbit/s Ethernet fiber uplink). A high-density FTTE design might use commonly available 24- or 48-port switches (these switches are configured with one 1 Gbit/s uplink port per twelve 100BASE-TX user ports). This relatively high work area-to-backbone port ratio provides better performance than is typically provided to enterprise users. Both low and high-density FTTE architectures provide excellent performance in terms of bandwidth delivered to the work area.

- Advantages
 - Low Cost
 - Non-blocking or low-blocking performance better supports convergence
 - Extremely flexible to deploy; supports Moves, Adds & Changes
 - Enables consolidation of electronics into a centralized Telecommunications Room
 - Allows the use of a variety of media from the TE to the user
- Disadvantages
 - TE location is near the user and must be secured

Chapter 2

Fiber to the X

Fiber to the x (FTTx) is a generic term for any broadband network architecture that uses optical fiber to replace all or part of the usual metal local loop used for last mile telecommunications. The generic term originated as a generalization of several configurations of fiber deployment (FTTN, FTTC, FTTB, FTTH...), all starting by FTT but differentiated by the last letter, which is substituted by an *x* in the generalization.

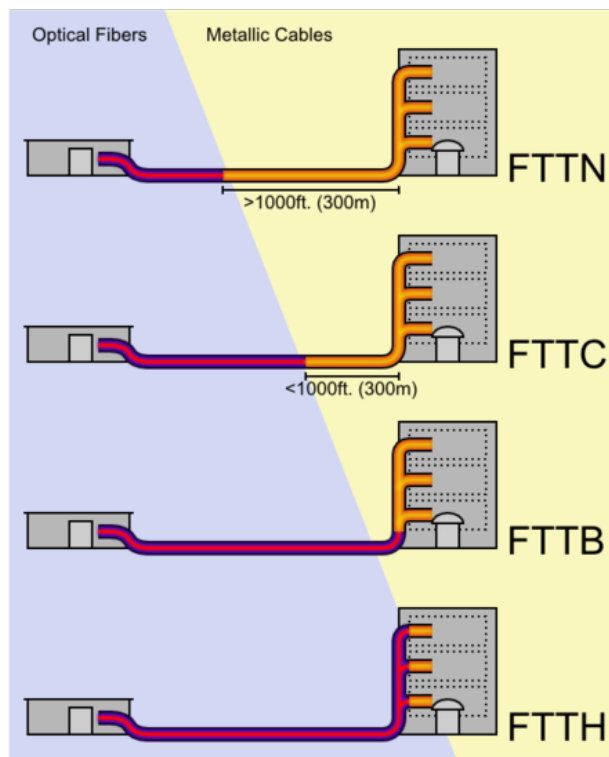

A schematic illustrating how FTTx architectures vary — with regard to the distance between the optical fiber and the end-user. The building on the left is the central office;

that on the right is one of the buildings served by the central office. Dotted rectangles represent separate living or office spaces within the same building.

Definition of terms

The telecommunications industry differentiates between several distinct configurations. The terms in most widespread use today are:

- FTTN - Fiber-to-the-node - fiber is terminated in a street cabinet up to several kilometers away from the customer premises, with the final connection being copper.
- FTTC - Fiber-to-the-cabinet or fiber-to-the-curb - this is very similar to FTTN, but the street cabinet is closer to the user's premises; typically within 300 m.
- FTTB - Fiber-to-the-building or Fiber-to-the-basement - fiber reaches the boundary of the building, such as the basement in a multi-dwelling unit, with the final connection to the individual living space being made via alternative means.
- FTTH - Fiber-to-the-home - fiber reaches the boundary of the living space, such as a box on the outside wall of a home.
- FTTP - Fiber-to-the premises - this term is used in several contexts: as a blanket term for both FTTH and FTTB, or where the fiber network includes both homes and small businesses.

To promote consistency, especially when comparing FTTH penetration rates between countries, the three FTTH Councils of Europe, North America and Asia-Pacific have agreed upon definitions for FTTH and FTTB. The FTTH Councils do not have formal definitions for FTTC and FTTN.

It is worth pointing out that fiber to the telecom enclosure (FTTE) is not considered to be part of the FTTx group of technologies, despite the similarity in name. FTTE is a form of structured cabling typically used in the enterprise local area network, where fiber is used to link the main computer equipment room to an enclosure close to the desk or workstation. Similarly, in fiber-to-the-desk a fiber connection is installed from the main computer room to a terminal at the desk.

Benefits of fiber in the access network

The speeds of fiber optic and copper cables are both limited by length, but copper is much more sharply limited in this respect. For example, gigabit Ethernet runs over relatively economical category 5e, category 6, or augmented category 6 unshielded twisted pair copper cabling but only to 100 meters. However, over the right kind of fiber, gigabit ethernet can easily reach distances of tens of kilometers.

Even in the commercial world, most computers have copper communication cables. But these cables are short, typically tens of meters. Most metropolitan network links (e.g., those based on telephone or cable television services) are several kilometers long, in the

range where fiber significantly outperforms copper. Replacing at least part of these links with fiber shortens the remaining copper segments and allows them to run much faster.

Fiber configurations that bring fiber right into the building can offer the highest speeds since the remaining segments can use standard Ethernet or coaxial cable. Fiber configurations that transition to copper in a street cabinet are generally too far from the users for standard Ethernet configurations over existing copper cabling. They generally use VDSL at (downstream) speeds of several tens of megabits per second.

Fiber is often said to be 'future proof' because the speed of the broadband connection is usually limited by the terminal equipment rather than the fiber itself, permitting at least some speed improvements by equipment upgrades before the fiber itself must be upgraded. Still, the type and length of employed fibers chosen, e.g. multimode vs single mode, are critical for applicability for future high gigabit connections.

Fiber to the node

Fiber to the node (FTTN), also called fiber to the neighborhood or fiber to the cabinet (FTTCab), is a telecommunication architecture based on fiber-optic cables run to a cabinet serving a neighborhood. Customers typically connect to this cabinet using traditional coaxial cable or twisted pair wiring. The area served by the cabinet is usually less than 1,500 m in radius and can contain several hundred customers. (If the cabinet serves an area of less than 300 m in radius then the architecture is typically called fiber to the curb.)

Fiber to the node allows delivery of broadband services such as high speed Internet. High speed communications protocols such as broadband cable access (typically DOCSIS) or some form of DSL are used between the cabinet and the customers. The data rates vary according to the exact protocol used and according to how close the customer is to the cabinet.

Unlike the competing fiber to the premises technology, fiber to the node often uses the existing coaxial or twisted pair infrastructure to provide last mile service. For this reason, fiber to the node is less costly to deploy. In the long-term, however, its bandwidth potential is limited relative to implementations which bring the fiber still closer to the subscriber.

Fiber to the last amplifier

FTTLA are the initials of *Fiber To The Last Amplifier*. Network cables being able to use several amplifiers, FTTLA aims at replacing the coaxial cable to the last amplifier (towards the subscriber) by optical fiber. It acts as a new technology aiming at re-using the network cables existing in particular on the final part while installing of optical fiber more closely to the subscriber while using the coaxial cable of the networks cables for the "last mile" or "last meters" connected with the subscriber.

Fiber to the last amplifier (FtLA) node is an efficient tool to deploy fiber deeper into the CATV network architecture and add most desirable aspects of scalability (performance and reliability) which are necessary when new services (i.e. "triple play", video on demand, gaming) are introduced.

FTTLA is a technology which assists hybrid fiber-coaxial CATV networks to provide to their customers more bandwidth. Using a replacement of all coaxial active equipments by nodes (optical receiver) with high power output (up to 117 dBuV). The coaxial is maintained from the node to the customer without any active equipment in between.

From the optical sender to the node, it uses fiber which is split by 4 or by 8 depending on the distance and on the output power of the optical sender (from 6 to 16 dBm).

Also, IM2, IM3 and C/N are modified for a better network and it also has other benefits such as power saving in the network, as the power consumption is lower than a normal HFC network (up to 40%).

Fiber to the curb

Fiber to the curb (FTTC) is a telecommunications system based on fiber-optic cables run to a platform that serves several customers. Each of these customers has a connection to this platform via coaxial cable or twisted pair.

Fiber to the curb allows delivery of broadband services such as high speed internet. High speed communications protocols such as broadband cable access (typically DOCSIS) or some form of DSL are used between the cabinet and the customers. The data rates vary according to the exact protocol used and according to how close the customer is to the cabinet.

FTTC is subtly distinct from FTTN or FTTP (all are versions of Fiber in the Loop). The main difference is the placement of the cabinet. FTTC will be placed near the "curb" which differs from FTTN which is placed far from the customer and FTTP which is placed right at the serving location.

Unlike the competing fiber to the premises (FTTP) technology, fiber to the curb can use the existing coaxial or twisted pair infrastructure to provide last mile service. For this reason, fiber to the curb costs less to deploy. However, it also has lower bandwidth potential than fiber to the premises.

In the United States of America and Canada, the largest deployment of FTTC was carried out by BellSouth Telecommunications. With the acquisition of BellSouth by AT&T, deployment of FTTC will end. Future deployments will be based on either FTTN or FTTP. Existing FTTC plant may be removed and replaced with FTTP.

Fiber to the premises

Fiber to the premises is a form of fiber-optic communication delivery in which an optical fiber is run from the central office all the way to the premises occupied by the subscriber. Fiber to the premises is often abbreviated with the acronym FTTP. However, this acronym has become ambiguous and may instead refer to a form of fiber to the curb where the fiber terminates at a utility pole without reaching the premises.

FTTH vs. FTTB

Fiber to the premises can be categorized according to where the optical fiber ends:

- FTTH (fiber to the home) is a form of fiber optic communication delivery in which the fiber extends from the central office to the subscriber's living or working space. Once at the subscriber's living or working space, the signal may be conveyed throughout the space using any means, including twisted pair, coaxial cable, wireless, power line communication, or optical fiber.
- FTTB (fiber to the building, also called fiber to the basement) is a form of fiber optic communication delivery in which the optical fiber terminates before actually reaching the subscribers living or working space itself, but does extend to the property containing that living or working space. The signal is conveyed the final distance using any non-optical means, including twisted pair, coaxial cable, wireless, or power line communication. By definition, FTTB necessarily applies only to those properties which contain multiple living or working spaces.

An apartment building may provide an example of the distinction between FTTH and FTTB. If a fiber is run to a panel at each subscriber's apartment, this is FTTH. If instead the fiber goes only as far as the apartment building's shared electrical room, then this is FTTB.

Direct fiber

The simplest optical distribution network can be called direct fiber. In this architecture, each fiber leaving the central office goes to exactly one customer. Such networks can provide excellent bandwidth since each customer gets their own dedicated fiber extending all the way to the central office. However, this approach is about 10% more costly due to the amount of fiber and central office machinery required. The approach is generally favored by new entrants and competitive operators. A benefit of this approach is that it doesn't exclude any layer 2 networking technologies, be they Passive optical network, Active Optical Network, etc. From a regulatory point of view it leads to least implications as any form of regulatory remedy is still possible using this topology.

Shared fiber

More commonly each fiber leaving the central office is actually shared by many customers. It is not until such a fiber gets relatively close to the customers that it is split into individual customer-specific fibers. There are two competing optical distribution network architectures which achieve this split: active optical networks (AONs) and passive optical networks (PONs).

Active optical network

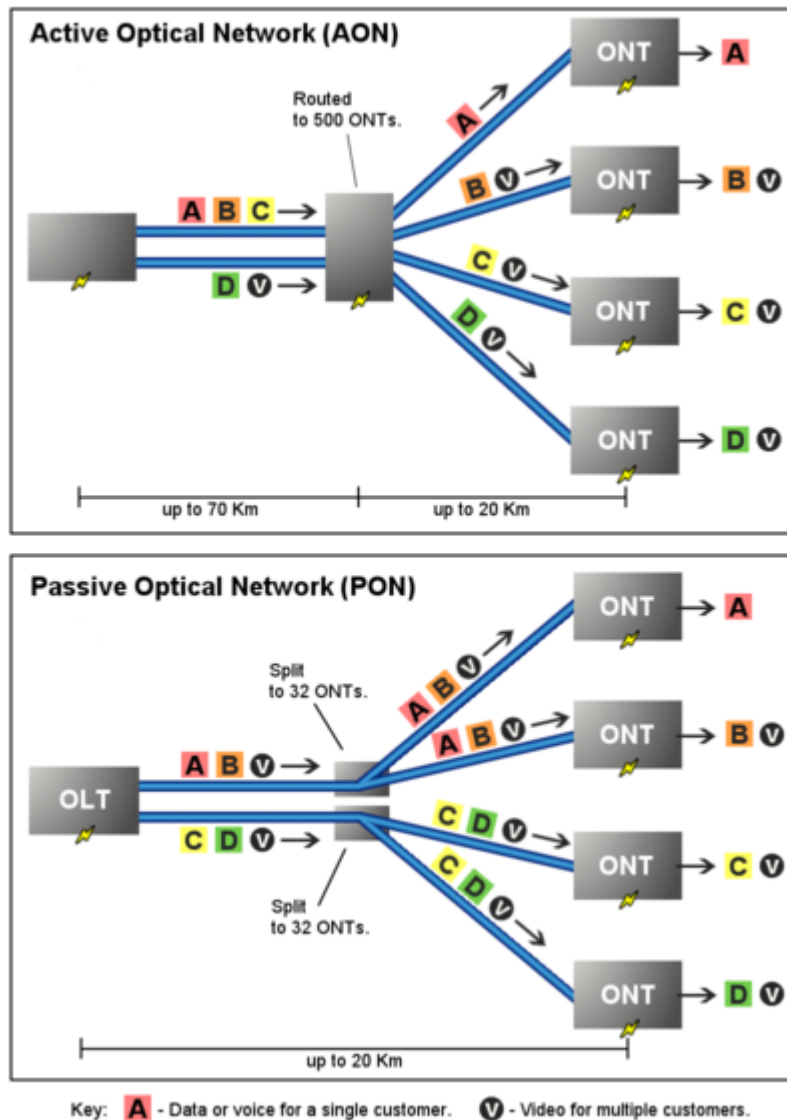

Comparison showing how a typical active optical network handles downstream traffic differently than a typical passive optical network. The type of active optical network

shown is a star network capable of multicasting. The type of passive optical network shown is a star network having multiple splitters housed in the same cabinet.

Active optical networks rely on some sort of electrically powered equipment in Optical Distribution Network(ODN) to distribute the signal, such as a switch or router. Normally, optical signals need O-E-O transformation in ODN. Each signal leaving the central office is directed only to the customer for which it is intended. Incoming signals from the customers avoid colliding at the intersection because the powered equipment there provides buffering.

As of 2007, the most common type of active optical networks are called active Ethernet, a type of Ethernet in the first mile (EFM). Active Ethernet uses optical Ethernet switches to distribute the signal, thus incorporating the customers' premises and the central office into one giant switched Ethernet network. Such networks are identical to the Ethernet computer networks used in businesses and academic institutions, except that their purpose is to connect homes and buildings to a central office rather than to connect computers and printers within a campus. Each switching cabinet can handle up to 1,000 customers, although 400-500 is more typical. This neighborhood equipment performs layer 2/layer 3 switching and routing, offloading full layer 3 routing to the carrier's central office. The IEEE 802.3ah standard enables service providers to deliver up to 100 Mbit/s full-duplex over one single-mode optical fiber to the premises depending on the provider. Speeds of 1Gbit/s are becoming commercially available.

Passive optical network

A passive optical network (PON) is a point-to-multipoint, fiber to the premises network architecture in which unpowered optical splitters are used to enable a single optical fiber to serve multiple premises, typically 32-128. A PON configuration reduces the amount of fiber and central office equipment required compared with point to point architectures.

Downstream signal coming from the central office is broadcast to each customer premises sharing a fiber. Encryption is used to prevent eavesdropping.

Upstream signals are combined using a multiple access protocol, invariably time division multiple access (TDMA). The OLTs "range" the ONUs in order to provide time slot assignments for upstream communication.

Electrical portion

Once on private property, the signal typically travels the final distance to the end user's equipment using an electrical format.

A device called an Optical Network Terminal (ONT), also called an Optical Network Unit (ONU), converts the optical signal into an electrical signal. (ONT is an ITU-T term, whereas ONU is an IEEE term, but the two terms mean exactly the same thing.) Optical network terminals require electrical power for their operation, so some providers connect

them to back-up batteries in case of power outages. Optical network units use thin film filter technology to convert between optical and electrical signals.

For fiber to the home and for some forms of fiber to the building, it is common for the building's existing phone systems, local area networks, and cable TV systems to connect directly to the ONT.

If all three systems cannot directly reach the ONT, it is possible to combine signals and transport them over a common medium. Once closer to the end-user, equipment such as a router, modem, and/or network interface module can separate the signals and convert them into the appropriate protocol. For example, one solution for apartment buildings uses VDSL to combine data (and / or video) with voice. With this approach, the combined signal travels through the building over the existing telephone wiring until it reaches the end-user's living space. Once there, a VDSL modem copies the data and video signals and converts them into Ethernet protocol. These are then sent over the end user's category 5 cable. A network interface module can then separate out the video signal and convert it into an RF signal that is sent over the end-user's coaxial cable. The voice signal continues to travel over the phone wiring and is sent through DSL filters to remove the video and data signals. An alternative strategy allows data and / or voice to be transmitted over coaxial cable. In yet another strategy, some office buildings dispense with the telephone wiring altogether, instead using voice over Internet Protocol phones that can plug directly into the local area network.

Chapter 3

Last Mile

The "**last mile**" or "**last kilometer**" is the final leg of delivering connectivity from a communications provider to a customer. The phrase is therefore often used by the telecommunications and cable television industries. The actual distance of this leg may be considerably more than a mile, especially in rural areas. It is typically seen as an expensive challenge because "fanning out" wires and cables is a considerable physical undertaking. Because the last mile of a network to the user is also the first mile from the user to the world in regards to sending data (such as uploading), the term "*first mile*" is sometimes used.

To solve the problem of providing enhanced services over the last mile, some firms have been mixing networks for decades. One example is Fixed Wireless Access, where a wireless network is used instead of wires to connect a stationary terminal to the wireline network.

Various solutions are being developed which are seen as an alternative to the "last mile" of standard incumbent local exchange carriers: these include WiMAX and BPL (Broadband over Power Line) applications.

Business "last mile"

Connectivity from the local telephone exchanges to the customer premises is also called the "last mile". In many countries this is often an ISDN30 connection, delivered through either a copper or fibre cable. This ISDN30 can carry 30 simultaneous telephone calls and many direct dial telephone numbers, (DDI's).

When leaving the telephone exchange, the ISDN30 cable can be buried in the ground, usually in ducting, at very little depth. This makes any business telephone lines vulnerable to being dug up during streetworks, liable to flooding during heavy storms and general wear and tear due to natural elements. Loss, therefore, of the "last mile" will cause the failure to deliver any calls to the business affected. Business continuity planning often provides for this type of technical failure.

Any business with ISDN30 type of connectivity should provide for this failure within its business continuity planning. There are many ways to achieve this, as documented CPNI:

1. **Dual Parenting** is where the telephone carrier provides the same numbers from two different telephone exchanges. If the cable is damaged from one telephone exchange to the customer premises most of the calls can be delivered from the surviving route to the customer.
2. **Diverse Routing** is where the carrier can provide more than one route to bring the ISDN 30's from the exchange, or exchanges, (as in dual parenting), but they may share underground ducting and cabinets.
3. **Separacy** is where the carrier can provide more than one route to bring the ISDN 30's from the exchange, or exchanges, (as in dual parenting), but they may not share underground ducting and cabinets, and therefore should be absolutely separate from the telephone exchange to the customer premises.
4. **Exchange-based solutions** is where a specialist company working in association with the carriers offers an enhancement the to ability to divert ISDN30's upon failure to any other number or group of numbers. Carrier diversions are usually limited to all of the ISDN30 DDI numbers being delivered to 1 single number. In the UK, GemaTech offers this service in association with all of the carriers other than Verizon. By being in the exchanges, the GemaTech version offers a part diversion service if required and voice recording of calls if required.
5. **Non-exchange based diversion services** is where a specialist company working in association with BT offers an enhancement to the ability to divert ISDN30's upon failure to any other number or group of numbers. Carrier diversions are usually limited to all of the ISDN30 DDI numbers being delivered to 1 single number. In the UK Teamphone offers this service in association with BT. By not being in the exchanges, the Teamphone version offers an all or nothing diversion service if required and but does not offer voice recording of calls.
6. **Ported number services** is where customers numbers can be ported to a specialist company where the numbers are pointed to the ISDN30 DDI numbers during business as usual and delivered to alternative numbers during a business continuity need. These are generally carrier independent and there are a number of companies offering such solutions in the UK.
7. **Hosted numbers** is where the carriers or specialist companies can host the customers numbers within their own or the carriers networks and deliver calls over an IP network to the customers sites. When a diversion service is required, the calls can be pointed to alternative numbers.
8. **Inbound numbers, (08 type services)** is where the carriers or specialist companies can offer 08/05/03 prefixed numbers to deliver to the ISDN30 DDI numbers and can point them to alternative numbers in the event of a diversion requirement. Both carriers and specialist companies offer this type of service in the UK

Existing delivery system problems

The increasing worldwide demand for rapid, low-latency and high-volume communication of information to homes and businesses has made economical information distribution and delivery increasingly important. As demand has escalated, particularly fueled by the widespread adoption of the Internet, the need for economical high-speed access by end-users located at millions of locations has ballooned as well. As requirements have changed, existing systems and networks which were initially pressed into service for this purpose have proven to be inadequate. To date, although a number of approaches have been tried and used, no single clear solution to this problem has emerged. This problem has been termed "The Last Mile Problem".

As expressed by Shannon's equation for channel information capacity, the omnipresence of noise in information systems sets a minimum signal-to-noise ratio (shortened as S/N) requirement in a channel, even when adequate spectral bandwidth is available. Since the integral of the rate of information transfer with respect to time is information quantity, this requirement leads to a corresponding minimum energy per bit. The problem of sending any given amount of information across a channel can therefore be viewed in terms of sending sufficient Information-Carrying Energy (ICE). For this reason the concept of an ICE "pipe" or "conduit" is relevant and useful for examining existing systems.

The distribution of information to a great number of widely separated end-users can be compared to the distribution of many other resources. Some familiar analogies are:

- blood distribution to a large number of cells over a system of veins, arteries and capillaries
- water distribution by a drip irrigation system to individual plants, including rivers, aqueducts, water mains etc.
- Nourishment to a plants leaves through roots, trunk and branches