

GLOBAL  
EDITION

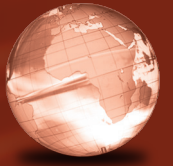

# Introductory Circuit Analysis

Fourteenth Edition

**Robert L. Boylestad**

**Brian A. Olivari**



Summary of Equations to Accompany  
**INTRODUCTORY CIRCUIT ANALYSIS, Fourteenth Edition, Global Edition**

by Robert L. Boylestad/Brian A. Olivari

© Copyright 2024 by Pearson Education, Ltd. All Rights Reserved.

ac

**Sinusoidal Alternating Waveforms**

**Sine wave**  $v = V_m \sin \alpha$ ,  $\alpha = \omega t = 2\pi ft$ ,  $f = 1/T$ , 1 radian = 57.3°, radians =  $(\pi/180^\circ) \times (\text{degrees})$ , degrees =  $(180^\circ/\pi) \times (\text{radians})$

**Identities**  $\sin(\omega t + 90^\circ) = \cos \omega t$ ,  $\sin \omega t = \cos(\omega t - (\pi/2))$ ,  $\sin(-\alpha) = -\sin \alpha$ ,  $\cos(-\alpha) = \cos \alpha$

**Average value**  $G =$  algebraic sum of areas/length of curve

**Effective (rms) value**  $I_{\text{rms}} = 0.707 I_m$ ,  $I_m = \sqrt{2} I_{\text{rms}}$

$$I_{\text{rms}} = \sqrt{\text{area}[i(t)]^2/T}$$

$$V_{\text{rms}} = 0.707 V_m$$

$$V_m = \sqrt{2} V_{\text{rms}}$$

$$V_{\text{rms}} = \sqrt{\text{area}[v(t)]^2/T}$$

**The Basic Elements and Phasors**

**R:**  $I_m = V_m/R$ , in phase **L:**  $X_L = \omega L$ ,  $v_L$  leads  $i_L$  by 90°

**C:**  $X_C = 1/\omega C$ ,  $i_C$  leads  $v_C$  by 90° **Power**  $P = (V_m I_m/2) \cos \theta =$

$$V_{\text{rms}} I_{\text{rms}} \cos \theta$$
 **R:**  $P = V_{\text{rms}} I_{\text{rms}} = I_{\text{rms}}^2 R = V_{\text{rms}}^2/R$

**Power factor**  $F_p = \cos \theta = P/V_{\text{rms}} I_{\text{rms}}$  **Rectangular form**  $C = A \pm jB$

**Polar form**  $C = C \angle \theta$  **Conversions**  $C = \sqrt{A^2 + B^2}$ ,  $\theta =$

$$\tan^{-1}(B/A)$$
,  $A = C \cos \theta$ ,  $B = C \sin \theta$  **Operations**  $j = \sqrt{-1}$ ,  $j^2 = -1$ ,  $1/j = -j$ ,  $C_1 \pm C_2 = (\pm A_1 \pm A_2) + j(\pm B_1 \pm B_2)$ ,

$$C_1 \cdot C_2 = C_1 C_2 \angle (\theta_1 + \theta_2)$$
,  $C_1/C_2 = (C_1/C_2) \angle (\theta_1 - \theta_2)$

**Series and Parallel ac Circuits**

**Elements**  $R \angle 0^\circ$ ,  $X_L \angle 90^\circ$ ,  $X_C \angle -90^\circ$

**Series**  $Z_T = Z_1 + Z_2 + Z_3 + \dots + Z_N$ ,  $I_s = E/Z_T$ ,  $F_p = R/Z_T$

**Voltage divider rule**  $V_x = Z_x E/Z_T$  **Parallel**  $Y_T = Y_1 + Y_2 +$

$$Y_3 + \dots + Y_N$$
,  $Z_T = Z_1 Z_2 / (Z_1 + Z_2)$ ,  $G \angle 0^\circ$ ,  $B_L \angle -90^\circ$ ,

$B_C \angle 90^\circ$ ,  $F_p = \cos \theta_T = G/Y_T$  **Current divider rule**  $I_1 =$

$$Z_2 I_T / (Z_1 + Z_2)$$
,  $I_2 = Z_1 I_T / (Z_1 + Z_2)$

**Equivalent circuits**  $R_s = R_p X_p^2 / (X_p^2 + R_p^2)$ ,  $X_s = R_p^2 X_p / (X_p^2 + R_p^2)$ ,

$$R_p = (R_s^2 + X_s^2)/R_s$$
,  $X_p = (R_s^2 + X_s^2)/X_s$

**Series-Parallel ac Networks**

Employ block impedances and obtain general solution for reduced network. Then substitute numerical values. General approach similar to that for dc networks.

**Methods of Analysis and Selected Topics (ac)**

**Source conversion**  $E = I Z_p$ ,  $Z_s = Z_p$ ,  $I = E/Z_s$

**Bridge networks**  $Z_1/Z_3 = Z_2/Z_4$

**Δ-Y, Y-Δ conversions** See dc coverage, replacing R by Z.

**Network Theorems (ac)**

Review dc content on other side.

**Thévenin's theorems** (dependent sources)  $E_{OC} = E_{Th}$ ,  $Z_{Th} = E_{OC}/I_{SC}$ ,

$Z_{Th} = E_g/I_g$  **Norton's theorems** (dependent sources)  $I_{SC} = I_N$ ,

$Z_N = E_{OC}/I_{SC}$ ,  $Z_N = E_g/I_g$  **Maximum power transfer theorem**

$$Z_L = Z_{Th}$$
,  $\theta_L = -\theta_{Th}$ ,  $P_{\text{max}} = E_{Th}^2/4R_{Th}$

**Power (ac)**

**R:**  $P = VI = V_m I_m/2 = I^2 R = V^2/R$  **Apparent power**  $S = VI$ ,

$P = S \cos \theta$ ,  $F_p = \cos \theta = P/S$  **Reactive power**  $Q = VI \sin \theta$

**L:**  $Q_L = VI = I^2 X_L = V^2/X_L$ , **C:**  $Q_C = VI = I^2 X_C = V^2/X_C$ ,

$$S_T = \sqrt{P_T^2 + Q_T^2}$$
,  $F_p = P_T/S_T$

**Resonances**

**Series**  $X_L = X_C$ ,  $f_s = 1/(2\pi\sqrt{LC})$ ,  $Z_{TS} = R$ ,  $Q_L = X_L/R$ ,  $Q_S = X_L/R =$

$$(1/R)\sqrt{L/C}$$
,  $V_L = Q_S E$ ,  $V_C = Q_S E$ ,  $P_{\text{HPF}} = (1/2)P_{\text{max}}$ ,

$$f_1 = (1/2\pi)[-R/2L + (1/2)\sqrt{(R/L)^2 + 4/LC}]$$
,  $f_2$  (use  $-R/2L$ ),

$$BW = f_2 - f_1 = R/2\pi L = f_s/Q_S$$
 **Parallel**  $X_{Lp} = X_C$ ,  $X_{Lp} =$

$$(R_L^2 + X_L^2)/X_L$$
,  $f_p = [1/(2\pi\sqrt{LC})]\sqrt{1 - (R_L^2 C/L)}$ ,  $Z_{TP} = R_s \parallel R_p$ ,

$$R_p = (R_L^2 + X_L^2)/R_L$$
,  $Q_p = (R_s \parallel R_p)/X_{Lp}$ ,  $BW = f_2 - f_1 = f_p/Q_p$

$$Q \geq 10$$
:  $Z_{Tp} \cong R_s \parallel Q^2 R_L$ ,  $X_{Lp} \cong X_L$ ,  $X_L = X_C$ ,  $f_p \cong 1/(2\pi\sqrt{LC})$ ,

$$Q_p = Q_L$$
,  $I_L = I_C \cong Q I_T$ ,  $BW = f_p/Q_p = R_L/2\pi L$

**Decibels, Filters, and Bode Plots**

**Logarithms**  $N = b^x$ ,  $x = \log_b N$ ,  $\log_e x = 2.3 \log_{10} x$ ,  $\log_{10} ab =$

$$\log_{10} a + \log_{10} b$$
,  $\log_{10} a/b = \log_{10} a - \log_{10} b$ ,  $\log_{10} a^n = n \log_{10} a$ ,

$$\text{dB} = 10 \log_{10} P_2/P_1$$
,  $\text{dB}_v = 20 \log_{10} V_2/V_1$

**R-C filters** (high-pass)  $f_c = 1/(2\pi RC)$ ,

$$V_o/V_i = R/\sqrt{R^2 + X_C^2} \angle \tan^{-1}(X_C/R)$$

$$\text{(low-pass)} f_c = 1/(2\pi RC)$$
,

$$V_o/V_i = X_C/\sqrt{R^2 + X_C^2} \angle -\tan^{-1} \frac{R}{X_C}$$

**Octave** 2 : 1, 6 dB/octave **Decade** 10 : 1, 20 dB/decade

**Transformers**

**Mutual inductance**  $M = k\sqrt{L_p L_s}$  **Iron-core**  $E_p = 4.44 f N_p \Phi_m$ ,

$$E_s = 4.44 f N_s \Phi_m$$
,  $E_p/E_s = N_p/N_s$ ,  $a = N_p/N_s$ ,  $I_p/I_s = N_s/N_p$ ,

$$Z_p = a^2 Z_L$$
,  $E_p I_p = E_s I_s$ ,  $P_i = P_o$  (ideal)

**Air-core**  $Z_i = Z_p + (\omega M)^2/(Z_s + Z_L)$

**Polyphase Systems**

**Y-Y system**  $I_{\phi g} = I_L = I_{\phi L}$ ,  $V_{\phi} = E_{\phi}$ ,  $E_L = \sqrt{3} V_{\phi}$  **Y-Δ system**

$$V_{\phi} = E_L$$
,  $I_L = \sqrt{3} I_{\phi}$  **Δ-Δ system**  $V_{\phi} = E_L = E_{\phi}$ ,  $I_L = \sqrt{3} I_{\phi}$

**Δ-Y system**  $E_L = \sqrt{3} V_{\phi}$ ,  $I_{\phi} = I_L$ ,  $E_L = E_{\phi}$  **Power**  $P_T = 3P_{\phi}$ ,

$$Q_T = 3Q_{\phi}$$
,  $S_T = 3S_{\phi} = \sqrt{3} E_L I_L$ ,  $F_p = P_T/S_T$

**Pulse Waveforms and the R-C Response**

**% tilt** =  $[(V_1 - V_2)/V] \times 100\%$  with  $V = (V_1 + V_2)/2$

**Pulse repetition frequency** (prf) =  $1/T$

**Duty cycle** =  $(t_p/T) \times 100\%$

$$V_{\text{av}} = (\text{duty cycle})(\text{peak value}) + (1 - \text{duty cycle}) \times (V_b)$$

**R-C circuits**  $v_C = V_i + (V_f - V_i)(1 - e^{-t/RC})$

**Compensated attenuator**  $R_p C_p = R_s C_s$

**Nonsinusoidal Circuits**

**Fourier series**  $f(\alpha) = A_0 + A_1 \sin \omega t + A_2 \sin 2\omega t + \dots +$

$$A_n \sin n\omega t + B_1 \cos \omega t + B_2 \cos 2\omega t + \dots + B_n \cos n\omega t$$

**Even function**  $f(\alpha) = f(-\alpha)$ , no  $B_n$  terms **Odd function**  $f(\alpha) =$

$$-f(-\alpha)$$
, no  $A_n$  terms, no odd harmonics if  $f(t) = f[(T/2) + t]$ , no even harmonics if  $f(t) = -f[(T/2) + t]$

**Effective (rms) value**

$$V_{(\text{rms})} = \sqrt{V_0^2 + (V_1^2 + \dots + V_m^2 + V_{m+1}^2 + \dots + V_n^2)/2}$$

$$\text{Power } P_T = V_0 I_0 + V_1 I_1 \cos \theta + \dots + V_n I_n \cos \theta_n = I_{\text{rms}}^2 R = V_{\text{rms}}^2/R$$

**Standard Resistor Values**

Ohms			Kilohms			Megohms	
(Ω)			(kΩ)			(MΩ)	
0.10	1.0	10	100	1000	10	100	1.0 10.0
0.11	1.1	11	110	1100	11	110	1.1 11.0
0.12	1.2	12	120	1200	12	120	1.2 12.0
0.13	1.3	13	130	1300	13	130	1.3 13.0
0.15	1.5	15	150	1500	15	150	1.5 15.0
0.16	1.6	16	160	1600	16	160	1.6 16.0
0.18	1.8	18	180	1800	18	180	1.8 18.0
0.20	2.0	20	200	2000	20	200	2.0 20.0
0.22	2.2	22	220	2200	22	220	2.2 22.0
0.24	2.4	24	240	2400	24	240	2.4 24.0
0.27	2.7	27	270	2700	27	270	2.7 27.0
0.30	3.0	30	300	3000	30	300	3.0 30.0
0.33	3.3	33	330	3300	33	330	3.3 33.0
0.36	3.6	36	360	3600	36	360	3.6 36.0
0.39	3.9	39	390	3900	39	390	3.9 39.0
0.43	4.3	43	430	4300	43	430	4.3 43.0
0.47	4.7	47	470	4700	47	470	4.7 47.0
0.51	5.1	51	510	5100	51	510	5.1 51.0
0.56	5.6	56	560	5600	56	560	5.6 56.0
0.62	6.2	62	620	6200	62	620	6.2 62.0
0.68	6.8	68	680	6800	68	680	6.8 68.0
0.75	7.5	75	750	7500	75	750	7.5 75.0
0.82	8.2	82	820	8200	82	820	8.2 82.0
0.91	9.1	91	910	9100	91	910	9.1 91.0

# INTRODUCTORY CIRCUIT ANALYSIS

Fourteenth Edition

Global Edition

**Robert L. Boylestad**  
**Brian A. Olivari**



**Product Management:** K. K. Neelakantan  
**Content Strategy:** Moasenla Jamir and Shahana  
Bhattacharya  
**Supplements:** Nitin Shankar, Nikhil Rakshit, and Tooba  
Shafique

**Production and Digital Studio:** Vikram Medepalli, Naina  
Singh, and Niharika Thapa  
**Rights and Permissions:** Anjali Singh and Ashish Vyas

Cover image: Vasylychenko / Shutterstock

Please contact <https://support.pearson.com/getsupport/s/> with any queries on this content.

*Pearson Education Limited*

KAO Two  
KAO Park  
Hockham Way  
Harlow, Essex  
CM17 9SR  
United Kingdom

and Associated Companies throughout the world

Visit us on the World Wide Web at: [www.pearsonglobaleditions.com](http://www.pearsonglobaleditions.com)

© Pearson Education Limited 2024

The rights of Robert L. Boylestad and Brian A. Olivari to be identified as the authors of this work have been asserted by them in accordance with the Copyright, Designs and Patents Act 1988.

*Authorized adaptation from the United States edition, entitled Introductory Circuit Analysis, 14th Edition, ISBN 978-0-13-759411-5 by Robert L. Boylestad and Brian A. Olivari published by Pearson Education © 2023.*

All rights reserved. No part of this publication may be reproduced, stored in a retrieval system, or transmitted in any form or by any means, electronic, mechanical, photocopying, recording or otherwise, without either the prior written permission of the publisher or a license permitting restricted copying in the United Kingdom issued by the Copyright Licensing Agency Ltd, Saffron House, 6–10 Kirby Street, London EC1N 8TS. For information regarding permissions, request forms and the appropriate contacts within the Pearson Education Global Rights & Permissions department, please visit [www.pearsoned.com/permissions/](http://www.pearsoned.com/permissions/).

Acknowledgments of third-party content appear on the appropriate page within the text.

PEARSON and ALWAYS LEARNING are exclusive trademarks owned by Pearson Education, Inc. or its affiliates in the U.S. and/or other countries.

Unless otherwise indicated herein, any third-party trademarks that may appear in this work are the property of their respective owners and any references to third-party trademarks, logos or other trade dress are for demonstrative or descriptive purposes only. Such references are not intended to imply any sponsorship, endorsement, authorization, or promotion of Pearson's products by the owners of such marks, or any relationship between the owner and Pearson Education, Inc. or its affiliates, authors, licensees, or distributors. This eBook may be available as a standalone product or integrated with other Pearson digital products like MyLab and Mastering. This eBook may or may not include all assets that were part of the print version. The publisher reserves the right to remove any material in this eBook at any time.

**ISBN 10 (print):** 1-292-72030-1

**ISBN 13 (print):** 978-1-292-72030-2

**ISBN 13 (uPDF eBook):** 978-1-292-45199-2

**British Library Cataloguing-in-Publication Data**

A catalogue record for this book is available from the British Library

eBook formatted by B2r Technologies Pvt. Ltd.

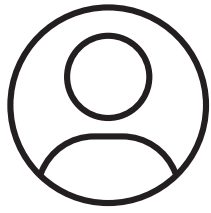

# Pearson's Commitment to Diversity, Equity, and Inclusion

**Pearson is dedicated to creating bias-free content that reflects the diversity, depth, and breadth of all learners' lived experiences.**

We embrace the many dimensions of diversity, including but not limited to race, ethnicity, gender, sex, sexual orientation, socioeconomic status, ability, age, and religious or political beliefs.

Education is a powerful force for equity and change in our world. It has the potential to deliver opportunities that improve lives and enable economic mobility. As we work with authors to create content for every product and service, we acknowledge our responsibility to demonstrate inclusivity and incorporate diverse scholarship so that everyone can achieve their potential through learning. As the world's leading learning company, we have a duty to help drive change and live up to our purpose to help more people create a better life for themselves and to create a better world.

## **Our ambition is to purposefully contribute to a world where:**

- Everyone has an equitable and lifelong opportunity to succeed through learning.
- Our educational content accurately reflects the histories and lived experiences of the learners we serve.
- Our educational products and services are inclusive and represent the rich diversity of learners.
- Our educational content prompts deeper discussions with students and motivates them to expand their own learning (and worldview).

## **Accessibility**

We are also committed to providing products that are fully accessible to all learners. As per Pearson's guidelines for accessible educational Web media, we test and retest the capabilities of our products against the highest standards for every release, following the WCAG guidelines in developing new products for copyright year 2022 and beyond.



You can learn more about Pearson's commitment to accessibility at

<https://www.pearson.com/uk/accessibility.html>

## **Contact Us**

While we work hard to present unbiased, fully accessible content, we want to hear from you about any concerns or needs with this Pearson product so that we can investigate and address them.



Please contact us with concerns about any potential bias at

<https://www.pearson.com/report-bias.html>.



For accessibility-related issues, such as using assistive technology with Pearson products, alternative text requests, or accessibility

documentation, email the Pearson Disability Support team at [disability.support@pearson.com](mailto:disability.support@pearson.com)



**Pearson**

*This page is intentionally left blank*

***Robert L. Boylestad***

*In loving memory of my wife Else  
and our children Eric, Alison and Stacey  
and our grandchildren Kelcy, Morgan,  
Britt, Samantha, Codie, Skylar, Lindsey  
and Aspen.*

***Brian A. Olivari***

*To my wife Margie  
and our children Jenny, Brittany,  
Meredith and Ben.*

*This page is intentionally left blank*

# Acknowledgments



The author would like to thank Don Johnson, an entrepreneur, author, and educator for his contribution.

## **CURRENT AND PREVIOUS EDITION REVIEWERS**

Kathleen Annis—AEMC Instruments  
Geno Anderson—Taitung Onesiphorus Children’s Home  
Jen Brophy—Red River Camps, Portage, Maine  
Tom Brown—LRAD Corporation  
Professor Leon Chua—University of California, Berkeley  
Professor Timothy Cochran—Alfred State College  
Professor Kenneth Cook—Lawrence Technological University  
Professor Raymond Cwieka—Essex College  
Professor Raj Desai—Midwestern State University  
Iulian Dobre—IMSAT Maritime  
Jessica Fiui—Honda Corporation  
Ron Forbes—B+K Precision, Inc.  
Felician Frentiu—IMSAT Maritime  
F. Halkiadakis—California University of Pennsylvania  
Professor Gerald Herder—Cal Poly Pomona  
Don Johnson—Professional Photographer  
Professor Ron Kalin—Penn State University  
Cara Kugler—Texas Instruments, Inc.  
Professor Ohbong Kwon—New York City College of Technology  
Professor David Malooly—Indiana State University  
Professor Don Mccann—Maine Maritime Academy, Castine, Maine  
Professor Kristen Dagan McGee—Naugatuck Valley Community College

Cheryl Mendenhall—Cadence Design Systems, Inc  
Professor Henry C. Miller—Bluefield State College  
Professor Mack Mofidi—DeVry University  
Professor Mostafa Mortezaie—DeVry University  
Rajashree Narendra—Dayananda Sagar University, Bangalore, India  
Professor Louis Nashelsky—CUNY  
Todd R. Nelson—Author and Educator  
Professor Brian Norton—Oklahoma State University  
Katie Parker—EarthRoamer Corp.  
Professor Alireza Rahrooh—Daytona State College  
Professor Gilberto Medeiros Ribeiro—Universidade Federal de Minas Gerais, Brazil  
Professor Patrick Riley—California University of Pennsylvania  
Peter Sanburn—Itron, Inc.  
Professor William Shepherd—Owens Community College  
Peggy Suggs—Edison Electric Institute  
Don Szymanski—Owens Community College  
Professor William Tefft—Maine Maritime Academy, Castine, Maine  
Mark Walters—National Instruments, Inc.  
Stanley Williams—Hewlett Packard, Inc.  
Professor Chen Xijou—Dalian University of Technology  
Professor Jianhua Joshua Yang—University of Massachusetts

## **ACKNOWLEDGMENTS FOR THE GLOBAL EDITION**

Pearson would like to acknowledge and thank the following for the Global Edition:

### **CONTRIBUTORS**

D. C. Meena—Delhi Technological University  
Nalan Özkurt—Yaşar University

### **REVIEWERS**

Gokhan Bora Esmer—Marmara University  
V. Jagadeesh Kumar—Indian Institute of Technology Madras  
Ha Pham—University of Technology Sydney

*This page is intentionally left blank*

# Brief Contents



<b>Chapter 1</b> <b>Introduction</b>	21	<b>Chapter 15</b> <b>Series ac Circuits</b>	641
<b>Chapter 2</b> <b>Voltage and Current</b>	55	<b>Chapter 16</b> <b>Parallel ac Circuits</b>	685
<b>Chapter 3</b> <b>Resistance</b>	89	<b>Chapter 17</b> <b>Series-Parallel ac Networks</b>	725
<b>Chapter 4</b> <b>Ohm's Law, Power, and Energy</b>	127	<b>Chapter 18</b> <b>Methods of Analysis and Selected Topics (ac)</b>	747
<b>Chapter 5</b> <b>Series dc Circuits</b>	153	<b>Chapter 19</b> <b>Network Theorems (ac)</b>	787
<b>Chapter 6</b> <b>Parallel dc Circuits</b>	207	<b>Chapter 20</b> <b>Power (ac)</b>	831
<b>Chapter 7</b> <b>Series-Parallel Circuits</b>	261	<b>Chapter 21</b> <b>Resonance</b>	865
<b>Chapter 8</b> <b>Methods of Analysis and Selected Topics (dc)</b>	305	<b>Chapter 22</b> <b>Decibels, Filters, and Bode Plots</b>	909
<b>Chapter 9</b> <b>Network Theorems</b>	367	<b>Chapter 23</b> <b>Transformers</b>	973
<b>Chapter 10</b> <b>Capacitors</b>	415	<b>Chapter 24</b> <b>Polyphase Systems</b>	1015
<b>Chapter 11</b> <b>Inductors</b>	475	<b>Chapter 25</b> <b>Pulse Waveforms and the R-C Response</b>	1055
<b>Chapter 12</b> <b>Magnetic Circuits</b>	519	<b>Chapter 26</b> <b>Nonsinusoidal Circuits</b>	1081
<b>Chapter 13</b> <b>Sinusoidal Alternating Waveforms</b>	545	<b>Appendices</b>	1105
<b>Chapter 14</b> <b>The Basic Elements and Phasors</b>	595	<b>Index</b>	1130

*This page is intentionally left blank*

# Contents



## Chapter 1

### Introduction 21

- 1.1 The Electrical/Electronics Industry 21
- 1.2 A Brief History 23
- 1.3 Units of Measurement 28
- 1.4 Systems of Units 29
- 1.5 Significant Figures, Accuracy, and Rounding Off 32
- 1.6 Powers of Ten 34
- 1.7 Fixed-Point, Floating-Point, Scientific, and Engineering Notation 38
- 1.8 Conversion Between Levels of Powers of Ten 40
- 1.9 Conversion Within and Between Systems of Units 42
- 1.10 Symbols 44
- 1.11 Conversion Tables 44
- 1.12 Calculators 45
- 1.13 Computer Analysis 49

## Chapter 2

### Voltage and Current 55

- 2.1 Introduction 55
- 2.2 Atoms and Their Structure 55
- 2.3 Voltage 58
- 2.4 Current 61
- 2.5 Voltage Sources 64
- 2.6 Ampere-Hour Rating 74
- 2.7 Battery Life Factors 75
- 2.8 Conductors and Insulators 77
- 2.9 Semiconductors 78
- 2.10 Ammeters and Voltmeters 78
- 2.11 Applications 81

## Chapter 3

### Resistance 89

- 3.1 Introduction 89
- 3.2 Resistance: Circular Wires 90
- 3.3 Wire Tables 93
- 3.4 Temperature Effects 96
- 3.5 Conductors and the Inferred Absolute Temperature ( $T_i$ ) 96
- 3.6 Temperature Coefficient of Resistance 98
- 3.7 PPM/ $^{\circ}$ C 99
- 3.8 Types of Resistors 99
- 3.9 Color Coding and Standard Resistor Values 104
- 3.10 Surface Mount Resistors 108
- 3.11 Conductance 109
- 3.12 Ohmmeters 110
- 3.13 Resistance: Metric Units 111
- 3.14 The Fourth Element—The Memristor 113
- 3.15 Superconductors 114
- 3.16 Thermistors 116
- 3.17 Photoconductive Cell 117
- 3.18 Varistors 117
- 3.19 Applications 118

## Chapter 4

### Ohm's Law, Power, and Energy 127

- 4.1 Introduction 127
- 4.2 Ohm's Law 127
- 4.3 Plotting Ohm's Law 130
- 4.4 Power 133
- 4.5 Energy 135
- 4.6 Efficiency 139
- 4.7 Circuit Breakers, GFCIs, and Fuses 142
- 4.8 Applications 143

## Chapter 5

### Series dc Circuits 153

- 5.1 Introduction 153
- 5.2 Series Resistors 154
- 5.3 Series Circuits 157
- 5.4 Power Distribution in a Series Circuit 163
- 5.5 Voltage Sources in Series 164
- 5.6 Kirchhoff's Voltage Law 166
- 5.7 Voltage Division in a Series Circuit 170
- 5.8 Interchanging Series Elements 174
- 5.9 Notation 175
- 5.10 Ground Connection Awareness 180
- 5.11 Voltage Regulation and the Internal Resistance of Voltage Sources 181
- 5.12 Loading Effects of Instruments 186
- 5.13 Protoboards (Breadboards) 188
- 5.14 Applications 190

## Chapter 6

### Parallel dc Circuits 207

- 6.1 Introduction 207
- 6.2 Parallel Resistors 207
- 6.3 Parallel Circuits 217
- 6.4 Power Distribution in a Parallel Circuit 223
- 6.5 Kirchhoff's Current Law 225
- 6.6 Current Divider Rule 229
- 6.7 Voltage Sources in Parallel 235
- 6.8 Open and Short Circuits 236
- 6.9 Voltmeter Loading Effects 239
- 6.10 Summary Table 241
- 6.11 Troubleshooting Techniques 242
- 6.12 Protoboards (Breadboards) 243
- 6.13 Applications 244

## Chapter 7

### Series-Parallel Circuits 261

- 7.1 Introduction 261
- 7.2 Series-Parallel Networks 262
- 7.3 Reduce and Return Approach 263
- 7.4 Block Diagram Approach 265

- 7.5 Descriptive Examples 269
- 7.6 Ladder Networks 277
- 7.7 Voltage Divider Supply (Unloaded and Loaded) 279
- 7.8 Potentiometer Loading 282
- 7.9 Impact of Shorts and Open Circuits 284
- 7.10 Ammeter, Voltmeter, and Ohmmeter Design 287
- 7.11 Applications 291

## Chapter 8

### Methods of Analysis and Selected Topics (dc) 305

- 8.1 Introduction 305
- 8.2 Current Sources 306
- 8.3 Branch-Current Analysis 312
- 8.4 Mesh Analysis (General Approach) 319
- 8.5 Mesh Analysis (Format Approach) 326
- 8.6 Nodal Analysis (General Approach) 330
- 8.7 Nodal Analysis (Format Approach) 338
- 8.8 Bridge Networks 342
- 8.9 Y- $\Delta$  (T- $\pi$ ) and  $\Delta$ -Y ( $\pi$ -T) Conversions 346
- 8.10 Applications 351

## Chapter 9

### Network Theorems 367

- 9.1 Introduction 367
- 9.2 Superposition Theorem 367
- 9.3 Thévenin's Theorem 375
- 9.4 Norton's Theorem 387
- 9.5 Maximum Power Transfer Theorem 391
- 9.6 Millman's Theorem 400
- 9.7 Substitution Theorem 403
- 9.8 Reciprocity Theorem 405

## Chapter 10

### Capacitors 415

- 10.1 Introduction 415
- 10.2 The Electric Field 415
- 10.3 Capacitance 417

- 10.4 Capacitors 421
- 10.5 Transients in Capacitive Networks:  
The Charging Phase 434
- 10.6 Transients in Capacitive Networks:  
The Discharging Phase 442
- 10.7 Initial Conditions 448
- 10.8 Instantaneous Values 451
- 10.9 Thévenin Equivalent:  $\tau = R_{TH}C$  452
- 10.10 The Current  $i_C$  455
- 10.11 Capacitors in Series and in Parallel 457
- 10.12 Energy Stored by a Capacitor 461
- 10.13 Stray Capacitances 461
- 10.14 Applications 462

## Chapter 11

### Inductors 475

- 11.1 Introduction 475
- 11.2 Magnetic Field 475
- 11.3 Inductance 480
- 11.4 Induced Voltage  $v_L$  486
- 11.5  $R$ - $L$  Transients: The Storage Phase 488
- 11.6 Initial Conditions 491
- 11.7  $R$ - $L$  Transients: The Release Phase 493
- 11.8 Thévenin Equivalent:  $\tau = L/R_{Th}$  498
- 11.9 Instantaneous Values 500
- 11.10 Average Induced Voltage:  $v_{L_{av}}$  501
- 11.11 Inductors in Series and in Parallel 503
- 11.12 Steady-State Conditions 504
- 11.13 Energy Stored by an Inductor 506
- 11.14 Applications 507

## Chapter 12

### Magnetic Circuits 519

- 12.1 Introduction 519
- 12.2 Magnetic Field 519
- 12.3 Reluctance 520
- 12.4 Ohm's Law for Magnetic Circuits 521
- 12.5 Magnetizing Force 521
- 12.6 Hysteresis 522
- 12.7 Ampère's Circuital Law 526
- 12.8 Flux  $\Phi$  527
- 12.9 Series Magnetic Circuits: Determining  $NI$  527

- 12.10 Air Gaps 531
- 12.11 Series-Parallel Magnetic Circuits 533
- 12.12 Determining  $\Phi$  535
- 12.13 Applications 537

## Chapter 13

### Sinusoidal Alternating Waveforms 545

- 13.1 Introduction 545
- 13.2 Sinusoidal ac Voltage Characteristics and  
Definitions 546
- 13.3 Frequency Spectrum 549
- 13.4 The Sinusoidal Waveform 553
- 13.5 General Format for the Sinusoidal Voltage or  
Current 557
- 13.6 Phase Relations 560
- 13.7 Average Value 566
- 13.8 Effective (rms) Values 572
- 13.9 Converters and Inverters 578
- 13.10 ac Meters and Instruments 581
- 13.11 Applications 584

## Chapter 14

### The Basic Elements and Phasors 595

- 14.1 Introduction 595
- 14.2 Response of Basic  $R$ ,  $L$ , and  $C$  Elements to a  
Sinusoidal Voltage or Current 598
- 14.3 Frequency Response of the Basic Elements 605
- 14.4 Average Power and Power Factor 611
- 14.5 Complex Numbers 617
- 14.6 Rectangular Form 617
- 14.7 Polar Form 618
- 14.8 Conversion Between Forms 619
- 14.9 Mathematical Operations with Complex  
Numbers 621
- 14.10 Calculator Methods with Complex Numbers 627
- 14.11 Phasors 629

## Chapter 15

### Series ac Circuits 641

- 15.1 Introduction 641
- 15.2 Resistive Elements 642

- 15.3 Inductive Elements 643
- 15.4 Capacitive Elements 645
- 15.5 Impedance Diagram 647
- 15.6 Series Configuration 648
- 15.7 Voltage Divider Rule 655
- 15.8 Frequency Response for Series ac Circuits 658
- 15.9 Summary: Series ac Circuits 671
- 15.10 Phase Measurements 671
- 15.11 Applications 674

## Chapter 16

### Parallel ac Circuits 685

- 16.1 Introduction 685
- 16.2 Total Impedance 685
- 16.3 Total Admittance 687
- 16.4 Parallel ac Networks 691
- 16.5 Current Divider Rule (CDR) 698
- 16.6 Frequency Response of Parallel Elements 698
- 16.7 Summary: Parallel ac Networks 708
- 16.8 Equivalent Circuits 709
- 16.9 Applications 714

## Chapter 17

### Series-Parallel ac Networks 725

- 17.1 Introduction 725
- 17.2 Illustrative Examples 725
- 17.3 Ladder Networks 735
- 17.4 Grounding 736
- 17.5 Applications 739

## Chapter 18

### Methods of Analysis and Selected Topics (ac) 747

- 18.1 Introduction 747
- 18.2 Independent Versus Dependent (Controlled) Sources 747
- 18.3 Source Conversions 748
- 18.4 Mesh Analysis 751
- 18.5 Nodal Analysis 759

- 18.6 Bridge Networks (ac) 770
- 18.7  $\Delta$ -Y, Y- $\Delta$  Conversions 775

## Chapter 19

### Network Theorems (ac) 787

- 19.1 Introduction 787
- 19.2 Superposition Theorem 787
- 19.3 Thévenin's Theorem 795
- 19.4 Norton's Theorem 807
- 19.5 Maximum Power Transfer Theorem 813
- 19.6 Substitution, Reciprocity, and Millman's Theorems 817
- 19.7 Application 818

## Chapter 20

### Power (ac) 831

- 20.1 Introduction 831
- 20.2 General Equation 831
- 20.3 Resistive Circuit 832
- 20.4 Apparent Power 834
- 20.5 Inductive Circuit and Reactive Power 836
- 20.6 Capacitive Circuit 839
- 20.7 The Power Triangle 841
- 20.8 The Total  $P$ ,  $Q$ , and  $S$  843
- 20.9 Power-Factor Correction 848
- 20.10 Power Meters 853
- 20.11 Effective Resistance 853
- 20.12 Applications 856

## Chapter 21

### Resonance 865

- 21.1 Introduction 865
- 21.2 Series Resonant Circuit 867
- 21.3 The Quality Factor ( $Q$ ) 870
- 21.4  $Z_T$  Versus Frequency 872
- 21.5 Selectivity 873
- 21.6  $V_R$ ,  $V_L$ , and  $V_C$  876
- 21.7 Practical Considerations 878
- 21.8 Summary 878
- 21.9 Examples (Series Resonance) 879

- 21.10 Parallel Resonant Circuit 881
- 21.11 Selectivity Curve for Parallel Resonant Circuits 885
- 21.12 Effect of  $Q_l \geq 10$  888
- 21.13 Summary Table 891
- 21.14 Examples (Parallel Resonance) 892
- 21.15 Applications 899

## Chapter 22

### Decibels, Filters, and Bode Plots 909

- 22.1 Introduction 909
- 22.2 Properties of Logarithms 914
- 22.3 Decibels 915
- 22.4 Filters 921
- 22.5 *R-C* Low-Pass Filter 922
- 22.6 *R-C* High-Pass Filter 927
- 22.7 Band-Pass Filters 930
- 22.8 Band-Stop Filters 934
- 22.9 Double-Tuned Filter 936
- 22.10 Other Filter Configurations 938
- 22.11 Bode Plots 941
- 22.12 Sketching the Bode Response 948
- 22.13 Additional Properties of Bode Plots 953
- 22.14 Crossover Networks 960
- 22.15 Applications 961

## Chapter 23

### Transformers 973

- 23.1 Introduction 973
- 23.2 Basic Operation 973
- 23.3 Reflected Impedance and Power 979
- 23.4 Impedance Matching, Isolation, and Displacement 981
- 23.5 Equivalent Circuit (Iron-Core Transformer) 986
- 23.6 Frequency Considerations 989
- 23.7 Series Connection of Mutually Coupled Coils 990
- 23.8 Air-Core Transformer 993
- 23.9 Nameplate Data 995
- 23.10 Types of Transformers 997

- 23.11 Tapped and Multiple-Load Transformers 999
- 23.12 Networks with Magnetically Coupled Coils 1000
- 23.13 Current Transformers 1001
- 23.14 Applications 1002

## Chapter 24

### Polyphase Systems 1015

- 24.1 Introduction 1015
- 24.2 Three-Phase Generator 1016
- 24.3 Y-Connected Generator 1017
- 24.4 Phase Sequence (Y-Connected Generator) 1019
- 24.5 Y-Connected Generator with a Y-Connected Load 1021
- 24.6 Y- $\Delta$  System 1023
- 24.7  $\Delta$ -Connected Generator 1025
- 24.8 Phase Sequence ( $\Delta$ -Connected Generator) 1026
- 24.9  $\Delta$ - $\Delta$   $\Delta$ -Y Three-Phase Systems 1026
- 24.10 Power 1028
- 24.11 Three-Wattmeter Method 1034
- 24.12 Two-Wattmeter Method 1035
- 24.13 Unbalanced, Three-Phase, Four-Wire, Y-Connected Load 1038
- 24.14 Unbalanced, Three-Phase, Three-Wire, Y-Connected Load 1040
- 24.15 Residential and Industrial Service Distribution Systems 1043

## Chapter 25

### Pulse Waveforms and the *R-C* Response 1055

- 25.1 Introduction 1055
- 25.2 Ideal Versus Actual 1055
- 25.3 Pulse Repetition Rate and Duty Cycle 1059
- 25.4 Average Value 1062
- 25.5 Transient *R-C* Networks 1063
- 25.6 *R-C* Response to Square-Wave Inputs 1066
- 25.7 Oscilloscope Attenuator and Compensating Probe 1073
- 25.8 Application 1075

## Chapter 26

### **Nonsinusoidal circuits** 1081

- 26.1 Introduction 1081
- 26.2 Fourier Series 1082
- 26.3 Fourier Expansion of a Square Wave 1089
- 26.4 Fourier Expansion of a Half-Wave Rectified Waveform 1091
- 26.5 Fourier Spectrum 1092
- 26.6 Circuit Response to a Nonsinusoidal Input 1093
- 26.7 Addition and Subtraction of Nonsinusoidal Waveforms 1099

## **Appendices** 1105

### **Appendix A**

Conversion Factors 1106

### **Appendix B**

Determinants 1109

### **Appendix C**

Greek Alphabet 1117

### **Appendix D**

Magnetic Parameter Conversions 1118

### **Appendix E**

Maximum Power Transfer Conditions 1119

### **Appendix F**

Answers to Selected Odd-Numbered Problems 1121

### **Index**

**1130**

# Preface



Welcome to the fourteenth edition. Over the fifty plus years since the first edition in 1968, the revisions have typically involved adding additional content based on the changes in curriculum. This new fourteenth edition is more about refining and updating content to provide a revision that ensures that the most current and relevant content is provided.

We are also excited about the ways students can purchase this textbook to ensure that they have the most effective and affordable options.

Students can choose from the print book or eText options. With the Pearson eText, students can search the text, use the study tools such as flashcards, make notes online, print out reading assignments that incorporate the notes they take during lectures, and bookmark important passages for later review.

The most notable changes include the following:

- The over 2000 images are as current as possible with many new or modified for this edition.
- The overall design of the text has been updated and enhanced for a more modern, accessible layout.
- The Multisim and PSpice computer material has been removed based on the vast majority of reviewers stating it was not covered. This valuable feedback indicated the importance of covering fundamental theories clearly rather than focusing on the mechanics of applying computer methods.
- Topics requiring a solid understanding of power factor, lead, and lag concepts have been significantly enhanced throughout the text.
- Laboratory experiments and summary of equations to accompany the text have been carefully reviewed for accuracy and changes made where required.
- Problems were carefully reviewed to ensure that they progressed from the simple to the more complex in each section.
- All solutions were checked carefully to ensure accuracy.

The TI 89 Titanium calculator continues to be the choice for this text, and we have provided sufficient detail in the text to perform all the mathematical techniques required

without having to refer to the calculator manual provided. In some cases, short-cut methods are introduced that are helpful in what they can perform in the shortest of time. In every respect we feel the TI-89 will serve the student well in their current studies and those to follow.

The feedback we have received from users of the thirteenth edition has been very helpful in defining areas that needed additional explanation and coverage. We always consider the effort to share feedback to be extraordinary since the instructor has so many other obligations in today's teaching environment. The comments we have received directly from users regarding potential errors in the solutions were taken seriously; and we reviewed their comments carefully to ensure that the content is correct and clarified. However, if you have questions about any of the content or solutions, we welcome your comments and will respond to any inquiry as soon as possible.

We realize there is always room for improvement, and while not as obvious as it was in earlier editions, there is always something you can do to take the text one step higher.

Robert L. Boylestad  
Brian A. Olivari

## SUPPLEMENTS

To enhance the learning process, a full supplements package accompanies this text and is available to instructors using the text for a course.

### *Instructor Resources*

Instructor Resources can be downloaded at [www.pearsonglobaleditions.com](http://www.pearsonglobaleditions.com). If you don't already have a username and password for access, you can request access at [www.pearsonglobaleditions.com](http://www.pearsonglobaleditions.com).

- **Instructor's Resource Manual**, containing text solutions.
- **PowerPoint Lecture Notes**.
- **TestGen**, a computerized test bank.

*This page is intentionally left blank*

# About the Authors



## **ROBERT L. BOYLESTAD**

The original contract for *Introductory Circuit Analysis* was signed in 1965 resulting in a publishing date of 1968—a current life history of some 60 years. The first 13 editions were written by me with an average time interval between editions of some 4.5 years. Upon completion of each edition, I felt that I had done all I can to make it the best available. However, as the years passed, there was always something that could withstand some improvement. For the 14th edition, I felt it wise to join hands with Professor Brian Olivari (Maine Maritime Academy) to be sure that I was fully aware of recent trends in the scope and depth of coverage in various subject areas. I feel it has been a wonderful union in developing the content of this edition.

My history in the educational field includes some 45 years at various professorial ranks in the City University, New York. There was also a period of some 10 years as assistant dean at the Thayer School of Engineering at Dartmouth. During my teaching career, I was fortunate enough to find the time to write some seven texts related to the electrical/electronics field. The two most successful are *Introductory Circuit Analysis* and *Electronic Devices and Circuit Theory* (co-authored with Professor Louis Nashelsky). The first one is in its 14th edition now, and the latter is in its 11th edition. Both texts have been translated into foreign languages with the ICA text translated into seven languages: Arabic, Chinese, French, Korean, Portuguese, Spanish, and Taiwanese. In addition to *Introductory Circuit Analysis*, a number of manuals and texts related to computer languages such as *BASIC Applied to Circuit Analysis*, *Manual for the IBM PC jr.*, and *BASIC for Electronics and Computer Technologies* were also published.

I look forward to any response from users of this 14th edition to ensure that the text remains current in the years to come.

## **BRIAN A. OLIVARI**

I was honored to have been asked by Professor Boylestad to collaborate on the 14th edition of *Introductory Circuit Analysis*. I could never have imagined being co-author on the latest edition when I first used Professor Boylestad's *Electronic Devices and Circuit Theory* textbook as a student back in 1977, and then the 11th edition of *Introductory Circuit Analysis* as a professor in 2008.

As a faculty member at Maine Maritime Academy for over 15 years, my teaching has focused on both electrical engineering and mathematics. In engineering, my primary interest has been in circuit analysis and electronics. In mathematics, I have been committed to preparing my math students to be successful at solving engineering problems.

Prior to teaching at Maine Maritime Academy, much of my professional experience came from working in the telecommunications industry at Western Electric, Rochester Telephone, and, most notably, Bell Labs where I was part of a team of engineers (systems, mechanical, electrical, and software) that developed the first-of-its-kind, stored-program-controlled D5 Digital Channel Bank System. Additionally, I served as an associate editor for the IEEE Solid-State Circuits Conference Digest of Technical Papers and taught briefly at Rochester Institute of Technology.

*This page is intentionally left blank*

# Introduction

# 1

## Objectives

- *Become aware of the rapid growth of the electrical/electronics industry over the past century.*
- *Understand the importance of applying a unit of measurement to a result or measurement and to ensure that the numerical values substituted into an equation are consistent with the unit of measurement of the various quantities.*
- *Become familiar with the International System of Units (SI) also referred to as the metric system.*
- *Understand the importance of powers of ten and how to work with them in any numerical calculation.*
- *Be able to convert any quantity, in any system of units, to another system with confidence.*

## 1.1 THE ELECTRICAL/ELECTRONICS INDUSTRY

Over the past few decades, technology has been changing at an ever-increasing rate. The pressure to develop new products, improve the performance and reliability of existing systems, and create new markets will only accelerate that rate. This pressure, however, is also what makes this field so exciting. New ways of storing and manipulating information, manufacturing integrated circuits, and developing software-embedded hardware systems that can “think” on their own based on input data are only a few possibilities.

Change has always been part of the human experience, but in the past, it was gradual. In recent years, however, the rate at which change in the electrical/electronics industry has been taking place is mind-boggling. Just think, for example, it was only a few years ago that “flatscreen” TVs, with wide, flat screens were introduced. Already, these have been eclipsed by much wider 4K ultra high definition (UHD) and 3D models.

Miniaturization has resulted in huge advances in electronic systems. For example, advancement in this technology has allowed cell phones that originally were the size of notebooks to now be smaller than a deck of playing cards. These so-called smartphones (devices), such as an iPhone 12 (2020), provide a multitude of extremely desirable features, in addition to being able to make simple telephone calls. Such features include a multi-touch glass capacitive screen, mp3 music player (iPod capability), web browser, email, text messaging, calendar and contacts, mobile game player, facial recognition (for security purposes), 4K HD video recording, high-resolution camera, video conferencing (FaceTime), GPS, Bluetooth, Wi-Fi, and the ability to run over 2 million software applications “Apps,” to name a few. Remarkably, this iPhone can also simultaneously store in its 256 GB memory: 6000 songs, 30,000 photos, as well as 18 hours of 4K video recorded at 30 fps. The Apple Watch, and other “smartwatches,” provide smartphone users with the ability to extend some of their devices’ capabilities to their wrists. Of course, laptop computers, iPads, and the like, have become ubiquitous in our society, primarily due to rapid technological advances in electronic systems. Nearly invisible and more powerful hearing aids with background noise cancellation features are now available for the hearing impaired. The list of new or improved products



continues to expand because significantly smaller electronic systems have been developed.

Most of us would agree that the computer has revolutionized our daily lives, in ways never imagined not that long ago—and it continues to do so in an accelerated fashion. When we compare the Guidance Computer aboard the Apollo 11 spacecraft, which landed on the moon back in 1969, with a commonly used cell phone in use today (the iPhone), we discover Apollo’s computer weighed 70 pounds and offered 2.3 MHz of processing power. Whereas, the performance data for even a much older generation iPhone 6 (2014) is staggering. At 3.36 billion instructions per second, the iPhone 6’s clock is 32,600 times faster than the best on board computers of the Apollo era and could perform instructions 120,000,000 times faster. You wouldn’t be wrong in saying an iPhone could be used to guide 120,000,000 Apollo-era spacecrafts to the moon, all at the same time. And . . . the iPhone weighs a mere 4.6 ounces!

Spurred on by the continuing process of miniaturization is a serious and growing interest in **artificial intelligence**, a term first used in 1955, as a drive to replicate the brain’s function with a packaged electronic equivalent. Although only about 3 pounds in weight, a size equivalent to about 2.5 pints of liquid with a power drain of about 20 watts (half that of a 40-watt light bulb), the brain contains over 100 billion neurons that have the ability to “fire” 200 times a second. Imagine the number of decisions made per second if all are firing at the same time! This number, however, is undaunting to researchers who feel that an electronic package capable of emulating the human brain is a genuine possibility in the next 10 to 15 years. Of course, including emotional qualities will be the biggest challenge, but otherwise researchers feel the advances of recent years are clear evidence that it is a real possibility. Consider how much of our daily lives is already decided for us with automatic brake control, programmed parallel parking, GPS, Web searching, and so on. The move is obviously strong and on its way. Also, when you consider how far we have come since the development of the first transistor some 67 years ago, who knows what might develop in the next decade or two?

This reduction in size of electronic systems is due primarily to an important innovation introduced in 1958—the **integrated circuit (IC)**. An integrated circuit can now contain features less than 50 nanometers across. The fact that measurements are now being made in nanometers has resulted in the terminology **nanotechnology** to refer to the production of integrated circuits called *nanochips*. To better appreciate the impact of nanometer measurements, consider drawing 100 lines within the boundaries of 1 inch. Then attempt drawing 1000 lines within the same length. Cutting 50-nanometer features would require drawing over 500,000 lines in 1 inch. The integrated circuit shown in Fig. 1.1 is an intel® Core™ i7 6-core processor that has around 3 billion transistors—a number hard to comprehend.

However, before a decision is made on such dramatic reductions in size, the system must be designed and tested to determine if it is worth constructing as an integrated circuit. That design process requires engineers who know the characteristics of each device used in the system, including undesirable characteristics that are part of any electronic element. In other words, there are *no ideal (perfect) elements* in an electronic design. Considering the limitations of each component is necessary

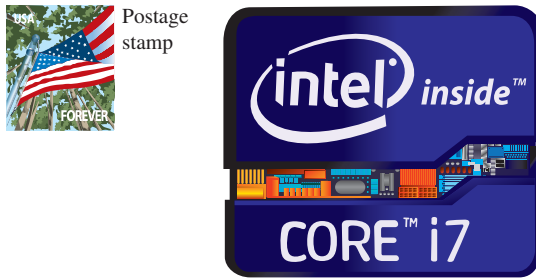

**FIG. 1.1**  
*Intel® Core™ i7 6-core processor.*

to ensure a reliable response under all conditions of temperature, vibration, and effects of the surrounding environment. To develop this awareness requires time and must begin with understanding the basic characteristics of the device, as covered in this text. One of the objectives of this text is to explain how ideal components work and their function in a network. Another is to explain conditions in which components may not be ideal.

One of the very positive aspects of the learning process associated with electric and electronic circuits is that once a concept or procedure is clearly and correctly understood, it will be useful throughout the career of the individual at any level in the industry. Once a law or equation is understood, it will not be replaced by another equation as the material becomes more advanced and complicated. For instance, one of the first laws to be introduced is Ohm's law. This law provides a relationship between forces and components that will always be true, no matter how complicated the system becomes. In fact, it is an equation that will be applied in various forms throughout the design of the entire system. The use of the basic laws may change, but the laws will not change and will always be applicable.

It is vitally important to understand that the learning process for circuit analysis is sequential. That is, the first few chapters establish the foundation for the remaining chapters. Failure to properly understand the opening chapters will only lead to difficulties understanding the material in the chapters to follow. This first chapter provides a brief history of the field followed by a review of mathematical concepts necessary to understand the rest of the material.

## 1.2 A BRIEF HISTORY

In the sciences, once a hypothesis is proven and accepted, it becomes one of the building blocks of that area of study, permitting additional investigation and development. Naturally, the more pieces of a puzzle available, the more obvious is the avenue toward a possible solution. In fact, history demonstrates that a single development may provide the key that will result in a mushrooming effect that brings the science to a new plateau of understanding and impact.

If the opportunity presents itself, read one of the many publications reviewing the history of this field. Space requirements are such that only a brief review can be provided here. There are many more contributors

than could be listed, and their efforts have often provided important keys to the solution of some very important concepts.

Throughout history, some periods were characterized by what appeared to be an explosion of interest and development in particular areas. As you will see from the discussion of the late 1700s and the early 1800s, inventions, discoveries, and theories came fast and furiously. Each new concept broadens the possible areas of application until it becomes almost impossible to trace developments without picking a particular area of interest and following it through. In the review, as you read about the development of radio, television, and computers, keep in mind that similar progressive steps were occurring in the areas of the telegraph, the telephone, power generation, the phonograph, appliances, and so on.

There is a tendency when reading about the great scientists, inventors, and innovators to believe that their contribution was a totally individual effort. In many instances, this was not the case. In fact, many of the great contributors had friends or associates who provided support and encouragement in their efforts to investigate various theories. At the very least, they were aware of one another's efforts to the degree possible in the days when a letter was often the best form of communication. In particular, note the closeness of the dates during periods of rapid development. One contributor seemed to spur on the efforts of the others or possibly provided the key needed to continue with the area of interest.

In the early stages, the contributors were not electrical, electronic, or computer engineers as we know them today. In most cases, they were physicists, chemists, mathematicians, or even philosophers. In addition, they were not from one or two communities of the Old World. The home country of many of the major contributors introduced in the paragraphs to follow is provided to show that almost every established community had some impact on the development of the fundamental laws of electrical circuits.

As you proceed through the remaining chapters of the text, you will find that a number of the units of measurement bear the name of major contributors in those areas—*volt* after Count Alessandro Volta, *ampere* after André Ampère, *ohm* after Georg Ohm, and so forth—fitting recognition for their important contributions to the birth of a major field of study.

Time charts indicating a limited number of major developments are provided in Fig. 1.2, primarily to identify specific periods of rapid development and to reveal how far we have come in the last 40 years. In essence, the current state of the art is a result of efforts that began in earnest some 250 years ago, with progress in the last 100 years being almost exponential.

As you read through the following brief review, try to sense the growing interest in the field and the enthusiasm and excitement that must have accompanied each new revelation. Although you may find some of the terms used in the review new and essentially meaningless, the remaining chapters will explain them thoroughly.

## The Beginning

The phenomenon of **static electricity** has intrigued scholars throughout history. The Greeks called the fossil resin substance so often used to demonstrate the effects of static electricity *elektron*, but no extensive study was made of the subject until William Gilbert researched the phenomenon in 1600. In the years to follow, there was a continuing investigation of electrostatic charge by many individuals, such as Otto von

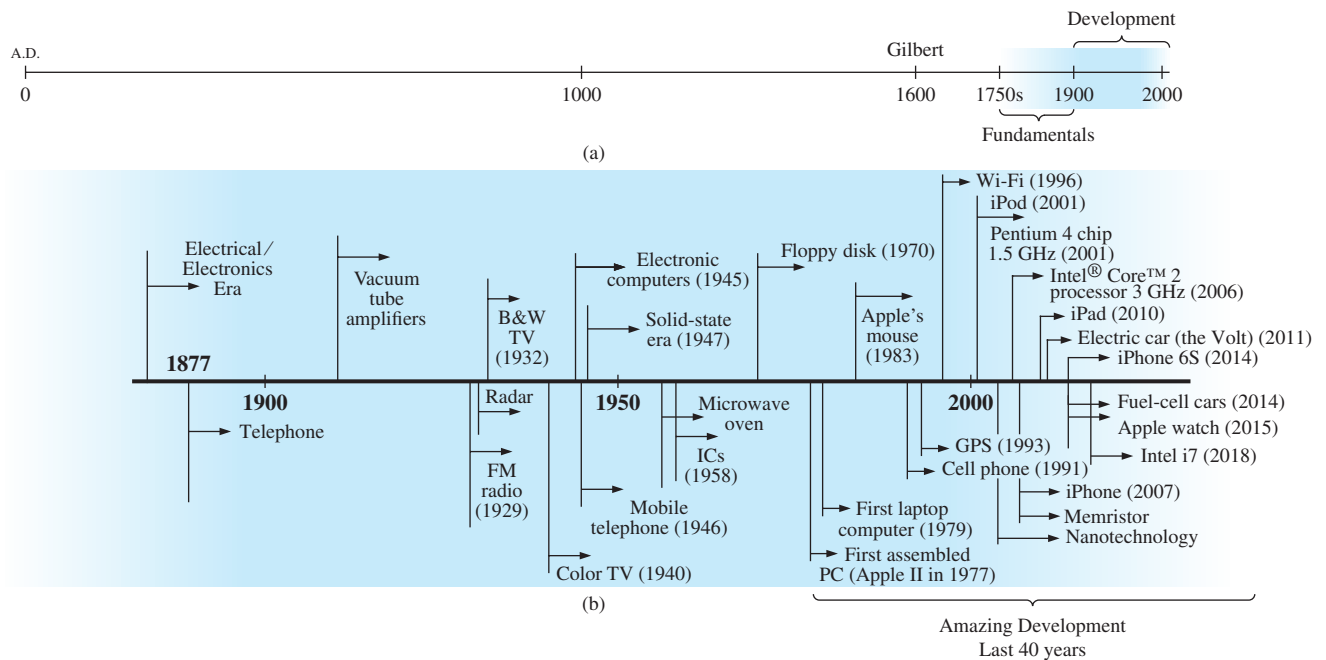

**FIG. 1.2**  
Time charts: (a) long-range, (b) expanded.

Guericke, who developed the first machine to generate large amounts of charge, and Stephen Gray, who was able to transmit electrical charge over long distances on silk threads. Charles DuFay demonstrated that charges either attract or repel each other, leading him to believe that there were two types of charge—a theory we subscribe to today with our defined positive and negative charges.

There are many who believe that the true beginnings of the electrical era lie with the efforts of Pieter van Musschenbroek and Benjamin Franklin. In 1745, van Musschenbroek introduced the **Leyden jar** for the storage of electrical charge (the first capacitor) and demonstrated electrical shock (and therefore the power of this new form of energy). Franklin used the Leyden jar some 7 years later to establish that lightning is simply an electrical discharge, and he expanded on a number of other important theories, including the definition of the two types of charge as *positive* and *negative*. From this point on, new discoveries and theories seemed to occur at an increasing rate as the number of individuals performing research in the area grew.

In 1784, Charles Coulomb demonstrated in Paris that the force between charges is inversely related to the square of the distance between the charges. In 1791, Luigi Galvani, professor of anatomy at the University of Bologna, Italy, performed experiments on the effects of electricity on animal nerves and muscles. The first **voltaic cell**, with its ability to produce electricity through the chemical action of a metal dissolving in an acid, was developed by another Italian, Alessandro Volta, in 1799.

The fever pitch continued into the early 1800s, with Hans Christian Oersted, a Danish professor of physics, announcing in 1820 a relationship between magnetism and electricity that serves as the foundation for the theory of **electromagnetism** as we know it today. In the same year, a French physicist, André Ampère, demonstrated that there are magnetic

effects around every current-carrying conductor and that current-carrying conductors can attract and repel each other just like magnets. In the period 1826 to 1827, a German physicist, Georg Ohm, introduced an important relationship between potential, current, and resistance that we now refer to as *Ohm's law*. In 1831, an English physicist, Michael Faraday, demonstrated his theory of *electromagnetic induction*, whereby a changing current in one coil can induce a changing current in another coil, even though the two coils are not directly connected. Faraday also did extensive work on a storage device he called the condenser, which we refer to today as a *capacitor*. He introduced the idea of adding a dielectric between the plates of a capacitor to increase the storage capacity (Chapter 10). James Clerk Maxwell, a Scottish professor of natural philosophy, performed extensive mathematical analyses to develop what are currently called *Maxwell's equations*, which support the efforts of Faraday linking electric and magnetic effects. Maxwell also developed the *electromagnetic theory of light* in 1862, which, among other things, revealed that electromagnetic waves travel through air at the velocity of light (186,000 miles per second or  $3 \times 10^8$  meters per second). In 1888, a German physicist, Heinrich Rudolph Hertz, through experimentation with lower-frequency electromagnetic waves (microwaves), substantiated Maxwell's predictions and equations. In the mid-1800s, Gustav Robert Kirchhoff introduced a series of laws of voltages and currents that find application at every level and area of this field (Chapters 5 and 6). In 1895, another German physicist, Wilhelm Röntgen, discovered electromagnetic waves of high frequency, commonly called *X-rays* today.

By the end of the 1800s, a significant number of the fundamental equations, laws, and relationships had been established, and various fields of study, including electricity, electronics, power generation and distribution, and communication systems, started to develop in earnest.

## The Age of Electronics

**Radio** The true beginning of the electronics era is open to debate and is sometimes attributed to efforts by early scientists in applying potentials across evacuated glass envelopes. However, many trace the beginning to Thomas Edison, who added a metallic electrode to the vacuum of the tube and discovered that a current was established between the metal electrode and the filament when a positive voltage was applied to the metal electrode. The phenomenon, demonstrated in 1883, was referred to as the **Edison effect**. In the period to follow, the transmission of radio waves and the development of the radio received widespread attention. In 1887, Heinrich Hertz, in his efforts to verify Maxwell's equations, transmitted radio waves for the first time in his laboratory. In 1896, an Italian scientist, Guglielmo Marconi (often called the father of the radio), demonstrated that telegraph signals could be sent through the air over long distances (2.5 kilometers) using a grounded antenna. In the same year, Aleksandr Popov sent what might have been the first radio message some 300 yards. The message was the name "*Heinrich Hertz*" in respect for Hertz's earlier contributions. In 1901, Marconi established radio communication across the Atlantic.

In 1904, John Ambrose Fleming expanded on the efforts of Edison to develop the first diode, commonly called **Fleming's valve**—actually the first of the *electronic devices*. The device had a profound impact on the design of detectors in the receiving section of radios. In 1906, Lee De Forest added a third element to the vacuum structure and created the

first amplifier, the triode. Shortly thereafter, in 1912, Edwin Armstrong built the first regenerative circuit to improve receiver capabilities and then used the same contribution to develop the first nonmechanical oscillator. By 1915, radio signals were being transmitted across the United States, and in 1918 Armstrong applied for a patent for the superheterodyne circuit employed in virtually every television and radio to permit amplification at one frequency rather than at the full range of incoming signals. The major components of the modern-day radio were now in place, and sales in radios grew from a few million dollars in the early 1920s to over \$1 billion by the 1930s. The 1930s were truly the golden years of radio, with a wide range of productions for the listening audience.

**Television (TV)** The 1930s were also the true beginnings of the television era, although development on the picture tube began in earlier years with Paul Nipkow and his *electrical telescope* in 1884 and John Baird and his long list of successes, including the transmission of television pictures over telephone lines in 1927 and over radio waves in 1928, and simultaneous transmission of pictures and sound in 1930. In 1932, NBC installed the first commercial television antenna on top of the Empire State Building in New York City, and RCA began regular broadcasting in 1939. World War II slowed development and sales, but in the mid-1940s the number of TV sets grew from a few thousand to a few million. Color television became popular in the early 1960s.

**Computers** The earliest computer system can be traced back to Blaise Pascal in 1642 with his mechanical machine for adding and subtracting numbers. In 1673, Gottfried Wilhelm von Leibniz used the *Leibniz wheel* to add multiplication and division to the range of operations, and in 1823 Charles Babbage developed the **difference engine** to add the mathematical operations of sine, cosine, logarithms, and several others. In the years to follow, improvements were made, but the system remained primarily mechanical until the 1930s when electromechanical systems using components such as relays were introduced. It was not until the 1940s that totally electronic systems became the new wave. It is interesting to note that, even though IBM was formed in 1924, it did not enter the computer industry until 1937. An entirely electronic system known as **ENIAC** was dedicated at the University of Pennsylvania in 1946. It contained 18,000 tubes and weighed 30 tons but was several times faster than most electromechanical systems. Although other vacuum tube systems were built, it was not until the birth of the solid-state era that computer systems experienced a major change in size, speed, and capability.

## The Solid-State Era

In 1947, physicists William Shockley, John Bardeen, and Walter H. Brattain of Bell Telephone Laboratories demonstrated the point-contact **transistor** (Fig. 1.3), an amplifier constructed entirely of solid-state materials with no requirement for a vacuum, glass envelope, or heater voltage for the filament. Although reluctant at first due to the vast amount of material available on the design, analysis, and synthesis of tube networks, the industry eventually accepted this new technology as the wave of the future. In 1958, the first **integrated circuit (IC)** chip was developed at Texas Instruments, and in 1961 the first commercial



**FIG. 1.3**  
*The first transistor.*  
SSPL/Getty Images

integrated circuit was manufactured by the Fairchild Corporation. Today some one trillion integrated circuits are manufactured each year.

It is impossible to review properly the entire history of the electrical/electronics field in a few pages. The effort here, both through the discussion and the time graphs in Fig. 1.2, was to reveal the amazing progress of this field in the last 50 years. The growth appears to be truly exponential since the early 1900s, raising the interesting question, Where do we go from here? The time chart suggests that the next few decades will probably contain many important innovative contributions that may cause an even faster growth curve than we are now experiencing.

### 1.3 UNITS OF MEASUREMENT

One of the most important rules to remember and apply when working in any field of technology is to use the correct units when substituting numbers into an equation. Too often we are so intent on obtaining a numerical solution that we overlook checking the units associated with the numbers being substituted into an equation. Results obtained, therefore, are often meaningless. Consider, for example, the following very fundamental physics equation:

$$\boxed{v = \frac{d}{t}} \quad \begin{array}{l} v = \text{velocity} \\ d = \text{distance} \\ t = \text{time} \end{array} \quad (1.1)$$

Assume, for the moment, that the following data are obtained for a moving object:

$$\begin{aligned} d &= 4000 \text{ ft} \\ t &= 1 \text{ min} \end{aligned}$$

and  $v$  is desired in miles per hour. Often, without a second thought or consideration, the numerical values are simply substituted into the equation, with the result here that

$$v = \frac{d}{t} = \frac{4000 \text{ ft}}{1 \text{ min}} = \cancel{4000 \text{ mph}}$$

As indicated above, the solution is totally incorrect. If the result is desired in *miles per hour*, the unit of measurement for distance must be *miles*, and that for time, *hours*. In a moment, when the problem is analyzed properly, the extent of the error will demonstrate the importance of ensuring that

***the numerical value substituted into an equation must have the unit of measurement specified by the equation.***

The next question is normally, How do I convert the distance and time to the proper unit of measurement? A method is presented in Section 1.9 of this chapter, but for now it is given that

$$\begin{aligned} 1 \text{ mi} &= 5280 \text{ ft} \\ 4000 \text{ ft} &= 0.76 \text{ mi} \\ 1 \text{ min} &= \frac{1}{60} \text{ h} = 0.017 \text{ h} \end{aligned}$$

Substituting into Eq. (1.1), we have

$$v = \frac{d}{t} = \frac{0.76 \text{ mi}}{0.017 \text{ h}} = \mathbf{44.71 \text{ mph}}$$

which is significantly different from the result obtained before.

To complicate the matter further, suppose the distance is given in kilometers, as is now the case on many road signs. First, we must realize that the prefix *kilo* stands for a multiplier of 1000 (to be introduced in Section 1.5), and then we must find the conversion factor between kilometers and miles. If this conversion factor is not readily available, we must be able to make the conversion between units using the conversion factors between meters and feet or inches, as described in Section 1.9.

Before substituting numerical values into an equation, try to mentally establish a reasonable range of solutions for comparison purposes. For instance, if a car travels 4000 ft in 1 min, does it seem reasonable that the speed would be 4000 mph? Obviously not! This self-checking procedure is particularly important in this day of the handheld calculator, when ridiculous results may be accepted simply because they appear on the digital display of the instrument.

Finally,

***if a unit of measurement is applicable to a result or piece of data, then it should be applied to the numerical value.***

To state that  $v = 44.71$  without including the unit of measurement *mph* is meaningless.

Eq. (1.1) is not a difficult one. A simple algebraic manipulation will result in the solution for any one of the three variables. However, in light of the number of questions arising from this equation, the reader may wonder if the difficulty associated with an equation will increase at the same rate as the number of terms in the equation. In the broad sense, this will not be the case. There is, of course, more room for a mathematical error with a more complex equation, but once the proper system of units is chosen and each term properly found in that system, there should be very little added difficulty associated with an equation requiring an increased number of mathematical calculations.

In review, before substituting numerical values into an equation, be absolutely sure of the following:

- 1. Each quantity has the proper unit of measurement as defined by the equation.***
- 2. The proper magnitude of each quantity as determined by the defining equation is substituted.***
- 3. Each quantity is in the same system of units (or as defined by the equation).***
- 4. The magnitude of the result is of a reasonable nature when compared to the level of the substituted quantities.***
- 5. The proper unit of measurement is applied to the result.***

## 1.4 SYSTEMS OF UNITS

In the past, the *systems of units* most commonly used were the English and metric, as outlined in Table 1.1. Note that while the English system is based on a single standard, the metric is subdivided into two interrelated standards: the **MKS** and the **CGS**. Fundamental quantities of these systems are compared in Table 1.1 along with their abbreviations. The MKS and CGS systems draw their names from the units of measurement used with each system; the MKS system uses *Meters*, *Kilograms*, and *Seconds*, while the CGS system uses *Centimeters*, *Grams*, and *Seconds*.

**TABLE 1.1**  
*Comparison of the English and metric systems of units.*

ENGLISH	METRIC		SI
	MKS	CGS	
<i>Length:</i> Yard (yd) (0.914 m)	Meter (m) (39.37 in.) (100 cm)	Centimeter (cm) (2.54 cm = 1 in.)	<b>Meter (m)</b>
<i>Mass:</i> <b>Slug</b> (14.6 kg)	Kilogram (kg) (1000 g)	Gram (g)	<b>Kilogram (kg)</b>
<i>Force:</i> <b>Pound (lb)</b> (4.45 N)	Newton (N) (100,000 dynes)	Dyne	<b>Newton (N)</b>
<i>Temperature:</i> Fahrenheit (°F) $\left( = \frac{9}{5}^{\circ}\text{C} + 32 \right)$	Celsius or Centigrade (°C) $\left( = \frac{5}{9} (^{\circ}\text{F} - 32) \right)$	Centigrade (°C)	<b>Kelvin (K)</b> $\text{K} = 273.15 + ^{\circ}\text{C}$
<i>Energy:</i> Foot-pound (ft-lb) (1.356 joules)	Newton-meter (N • m) or joule (J) (0.7376 ft-lb)	Dyne-centimeter or erg (1 joule = 10 <sup>7</sup> ergs)	<b>Joule (J)</b>
<i>Time:</i> Second (s)	Second (s)	Second (s)	<b>Second (s)</b>

Understandably, the use of more than one system of units in a world that finds itself continually shrinking in size, due to advanced technical developments in communications and transportation, would introduce unnecessary complications to the basic understanding of any technical data. The need for a standard set of units to be adopted by all nations has become increasingly obvious. The International Bureau of Weights and Measures located at Sèvres, France, has been the host for the General Conference of Weights and Measures, attended by representatives from all nations of the world. In 1960, the General Conference adopted a system called *Le Système International d'Unités* (International System of Units), which has the international abbreviation **SI**. It was adopted by the Institute of Electrical and Electronic Engineers (IEEE) in 1965 and by the United States of America Standards Institute (USASI) in 1967 as a standard for all scientific and engineering literature.

For comparison, the SI units of measurement and their abbreviations appear in Table 1.1. These abbreviations are those usually applied to each unit of measurement, and they were carefully chosen to be the most effective. Therefore, it is important that they be used whenever applicable to ensure universal understanding. Note the similarities of the SI system to the MKS system. This text uses, whenever possible and practical, all of the major units and abbreviations of the SI system in an effort to support the need for a universal system. Those readers requiring additional information on the SI system should contact the information office of the American Society for Engineering Education (ASEE).\*

Fig. 1.4 should help you develop some feeling for the relative magnitudes of the units of measurement of each system of units. Note in the figure the relatively small magnitude of the units of measurement for the CGS system.

\*American Society for Engineering Education (ASEE), 1818 N Street N.W., Suite 600, Washington, D.C. 20036-2479; (202) 331-3500; <http://www.asee.org/>.

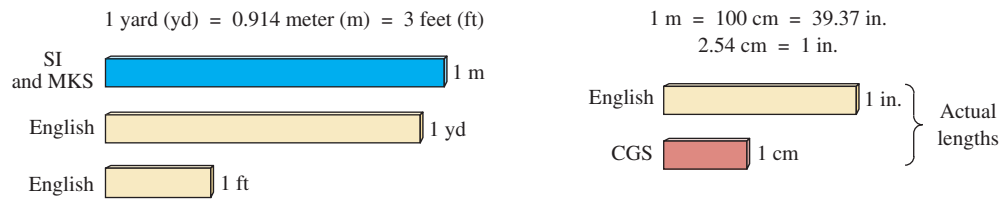
**Length:**

**Mass:**

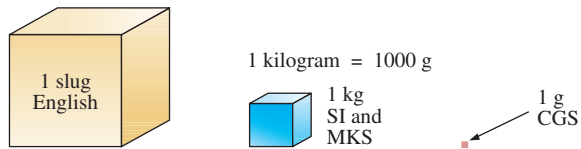
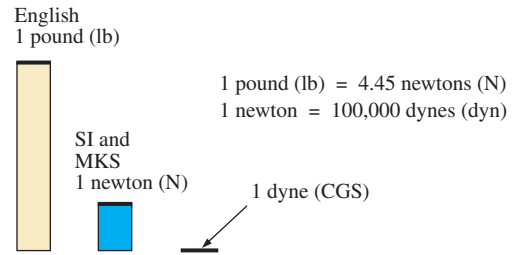
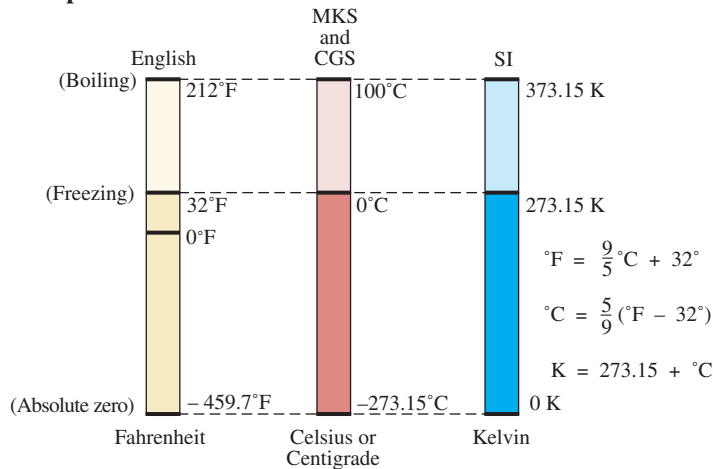
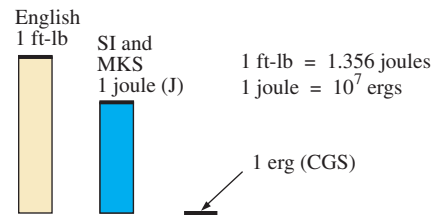
1 slug = 14.6 kilograms

**Force:**

**Temperature:**

**Energy:**

**FIG. 1.4**

Comparison of units of the various systems of units.

A standard exists for each unit of measurement of each system. The standards of some units are quite interesting.

The **meter** was originally defined in 1790 to be 1/10,000,000 the distance between the equator and either pole at sea level, a length preserved on a platinum-iridium bar at the International Bureau of Weights and Measures at Sèvres, France.

*The meter is now defined with reference to the speed of light in a vacuum, which is 299,792,458 m/s.*

*The kilogram is defined as a mass equal to 1000 times the mass of 1 cubic centimeter of pure water at 4°C.*

This standard is preserved in the form of a platinum-iridium cylinder in Sèvres.

The **second** was originally defined as 1/86,400 of the mean solar day. However, since Earth's rotation is slowing down by almost 1 second every 10 years,

*the second was redefined in 1967 as 9,192,631,770 periods of the electromagnetic radiation emitted by a particular transition of the cesium atom.*

## 1.5 SIGNIFICANT FIGURES, ACCURACY, AND ROUNDING OFF

This section emphasizes the importance of knowing the source of a piece of data, how a number appears, and how it should be treated. Too often we write numbers in various forms with little concern for the format used, the number of digits that should be included, and the unit of measurement to be applied.

For instance, measurements of 22.1 in. and 22.10 in. imply different levels of accuracy. The first suggests that the measurement was made by an instrument accurate only to the tenths place; the latter was obtained with instrumentation capable of reading to the hundredths place. The use of zeros in a number, therefore, must be treated with care, and the implications must be understood.

In general, there are two types of numbers: *exact* and *approximate*. Exact numbers are precise to the exact number of digits presented, just as we know that there are 12 apples in a dozen and not 12.1. Throughout the text, the numbers that appear in the descriptions, diagrams, and examples are considered *exact*, so that a battery of 100 V can be written as 100.0 V, 100.00 V, and so on, since it is 100 V at any level of precision. The additional zeros were not included for purposes of clarity. However, in the laboratory environment, where measurements are continually being taken and the level of accuracy can vary from one instrument to another, it is important to understand how to work with the results. Any reading obtained in the laboratory should be considered *approximate*. The analog scales with their pointers may be difficult to read, and even though the digital meter provides only specific digits on its display, it is limited to the number of digits it can provide, leaving us to wonder about the less significant digits not appearing on the display.

The precision of a reading can be determined by the number of *significant figures (digits)* present. Significant digits are those integers (0 to 9) that can be assumed to be accurate for the measurement being made. The result is that all nonzero numbers are considered significant, with zeros being significant in only some cases. For instance, the zeros in 1005 are considered significant because they define the size of the number and are surrounded by nonzero digits. For the number 0.4020, the zero to the left of the decimal point is not significant but clearly defines the location of the decimal point. The other two zeros define the magnitude of the number and the fourth-place accuracy of the reading.

When adding approximate numbers, it is important to be sure that the accuracy of the readings is consistent throughout. To add a quantity accurate only to the tenths place to a number accurate to the thousandths place will result in a total having accuracy only to the tenths place. One cannot expect the reading with the higher level of accuracy to improve the reading with only tenths-place accuracy.

***In the addition or subtraction of approximate numbers, the entry with the lowest level of accuracy determines the level of accuracy of the solution.***

**For the multiplication and division of approximate numbers, the result has the same number of significant figures as the number with the least number of significant figures.**

For approximate numbers (and exact numbers, for that matter), there is often a need to *round off* the result; that is, you must decide on the appropriate level of accuracy and alter the result accordingly. The accepted procedure is simply to note the digit following the last to appear in the rounded-off form, add a 1 to the last digit if it is greater than or equal to 5, and leave it alone if it is less than 5. For example,  $3.186 \cong 3.19 \cong 3.2$ , depending on the level of precision desired. The symbol  $\cong$  means *approximately equal to*.

---

**EXAMPLE 1.1** Perform the indicated operations with the following approximate numbers and round off to the appropriate level of accuracy.

- $532.6 + 4.02 + 0.036 = 536.656 \cong \mathbf{536.7}$  (as determined by 532.6)
- $0.04 + 0.003 + 0.0064 = 0.0494 \cong \mathbf{0.05}$  (as determined by 0.04)

---

**EXAMPLE 1.2** Round off the following numbers to the hundredths place.

- $32.419 = \mathbf{32.42}$
- $0.05328 = \mathbf{0.05}$

---

**EXAMPLE 1.3** Round off the result 5.8764 to

- tenths-place accuracy.
- hundredths-place accuracy.
- thousandths-place accuracy.

**Solution:**

- $\mathbf{5.9}$
- $\mathbf{5.88}$
- $\mathbf{5.876}$

---

For this text the level of accuracy to be carried through a series of calculations will be hundredths place. That is, at each stage of a development, exercise, or problem, the level of accuracy will be set using hundredths-place accuracy. Over a series of calculations this will naturally affect the accuracy of the final result but a limit has to be set or solutions will be carried to unwieldy levels.

For instance, let us examine the following product:

$$(9.64)(0.4896) = 4.68504$$

Clearly, we don't want to carry this level of accuracy through any further calculations in a particular example. Rather, using hundredths-place accuracy, we will write it as 4.69.

The next calculation may be

$$(4.69)(1.096) = 5.14024$$

which to hundredths-place accuracy is **5.14**. However, if we had carried the original product to its full accuracy, we would have obtained

$$(4.68504)(1.096) = 5.1348$$

or, to hundredths-place accuracy, **5.13**.

Obviously, 5.13 is the more accurate solution, so there is a loss of accuracy using rounded-off results. However, as indicated above, this text will round off the final and intermediate results to hundredths place for clarity and ease of comparison.

## 1.6 POWERS OF TEN

It should be apparent from the relative magnitude of the various units of measurement that very large and very small numbers are frequently encountered in the sciences. To ease the difficulty of mathematical operations with numbers of such varying size, *powers of ten* are usually employed. This notation takes full advantage of the mathematical properties of powers of ten. The notation used to represent numbers that are integer powers of ten is as follows:

$$\begin{array}{lll} 1 = 10^0 & 1/10 = & 0.1 = 10^{-1} \\ 10 = 10^1 & 1/100 = & 0.01 = 10^{-2} \\ 100 = 10^2 & 1/1000 = & 0.001 = 10^{-3} \\ 1000 = 10^3 & 1/10,000 = & 0.0001 = 10^{-4} \end{array}$$

In particular, note that  $10^0 = 1$ , and, in fact, any quantity to the zero power is 1 ( $x^0 = 1$ ,  $1000^0 = 1$ , and so on). Numbers in the list *greater than 1 are associated with positive powers of ten*, and numbers in the list *less than 1 are associated with negative powers of ten*.

A quick method of determining the proper power of ten is to place a caret mark to the right of the numeral 1 wherever it may occur; then count from this point to the number of places to the right or left before arriving at the decimal point. Moving to the right indicates a positive power of ten, whereas moving to the left indicates a negative power. For example,

$$\begin{array}{l} 10,000.0 = 1 \underbrace{0,000.}_1 = 10^{+4} \\ 0.00001 = 0.\underbrace{00001}_5 = 10^{-5} \end{array}$$

Some important mathematical equations and relationships pertaining to powers of ten are listed below, along with a few examples. In each case,  $n$  and  $m$  can be any positive or negative real number.

$$\boxed{\frac{1}{10^n} = 10^{-n} \quad \frac{1}{10^{-n}} = 10^n} \quad (1.2)$$

Eq. (1.2) clearly reveals that shifting a power of ten from the denominator to the numerator, or the reverse, requires simply changing the sign of the power.

**EXAMPLE 1.4**

- a.  $\frac{1}{1000} = \frac{1}{10^{+3}} = 10^{-3}$
- b.  $\frac{1}{0.00001} = \frac{1}{10^{-5}} = 10^{+5}$

The product of powers of ten:

$$(10^n)(10^m) = (10)^{(n+m)} \quad (1.3)$$

**EXAMPLE 1.5**

- a.  $(1000)(10,000) = (10^3)(10^4) = 10^{(3+4)} = 10^7$
- b.  $(0.00001)(100) = (10^{-5})(10^2) = 10^{(-5+2)} = 10^{-3}$

The division of powers of ten:

$$\frac{10^n}{10^m} = 10^{(n-m)} \quad (1.4)$$

**EXAMPLE 1.6**

- a.  $\frac{100,000}{100} = \frac{10^5}{10^2} = 10^{(5-2)} = 10^3$
- b.  $\frac{1000}{0.0001} = \frac{10^3}{10^{-4}} = 10^{(3-(-4))} = 10^{(3+4)} = 10^7$

Note the use of parentheses in part (b) to ensure that the proper sign is established between operators.

The power of powers of ten:

$$(10^n)^m = 10^{nm} \quad (1.5)$$

**EXAMPLE 1.7**

- a.  $(100)^4 = (10^2)^4 = 10^{(2)(4)} = 10^8$
- b.  $(1000)^{-2} = (10^3)^{-2} = 10^{(3)(-2)} = 10^{-6}$
- c.  $(0.01)^{-3} = (10^{-2})^{-3} = 10^{(-2)(-3)} = 10^6$

For those of you with the interest, there is a YouTube video, “Powers of Ten,” produced in 1977 that is quite well done. The video presents the subject through the lens of the world we live in. A recommended viewing.

**Basic Arithmetic Operations**

Let us now examine the use of powers of ten to perform some basic arithmetic operations using numbers that are not just powers of ten. The number 5000 can be written as  $5 \times 1000 = 5 \times 10^3$ , and the number 0.0004 can be written as  $4 \times 0.0001 = 4 \times 10^{-4}$ . Of course,  $10^5$  can also be written as  $1 \times 10^5$  if it clarifies the operation to be performed.

**Addition and Subtraction** To perform addition or subtraction using powers of ten, the power of ten *must be the same for each term*; that is,

$$A \times 10^n \pm B \times 10^n = (A \pm B) \times 10^n \quad (1.6)$$

Eq. (1.6) covers all possibilities, but students often prefer to remember a verbal description of how to perform the operation.

Eq. (1.6) states

*when adding or subtracting numbers in a power-of-ten format, be sure that the power of ten is the same for each number. Then separate the multipliers, perform the required operation, and apply the same power of ten to the result.*

---

### EXAMPLE 1.8

$$\begin{aligned} \text{a. } 6300 + 75,000 &= (6.3)(1000) + (75)(1000) \\ &= 6.3 \times 10^3 + 75 \times 10^3 \\ &= (6.3 + 75) \times 10^3 \\ &= \mathbf{81.3 \times 10^3} \\ \text{b. } 0.00096 - 0.000086 &= (96)(0.00001) - (8.6)(0.00001) \\ &= 96 \times 10^{-5} - 8.6 \times 10^{-5} \\ &= (96 - 8.6) \times 10^{-5} \\ &= \mathbf{87.4 \times 10^{-5}} \end{aligned}$$

---

**Multiplication** In general,

$$(A \times 10^n)(B \times 10^m) = (A)(B) \times 10^{n+m} \quad (1.7)$$

revealing that the *operations with the power of ten can be separated from the operation with the multipliers*.

Eq. (1.7) states

*when multiplying numbers in the power-of-ten format, first find the product of the multipliers and then determine the power of ten for the result by adding the power-of-ten exponents.*

---

### EXAMPLE 1.9

$$\begin{aligned} \text{a. } (0.0002)(0.000007) &= [(2)(0.0001)][(7)(0.000001)] \\ &= (2 \times 10^{-4})(7 \times 10^{-6}) \\ &= (2)(7) \times (10^{-4})(10^{-6}) \\ &= \mathbf{14 \times 10^{-10}} \\ \text{b. } (340,000)(0.00061) &= (3.4 \times 10^5)(61 \times 10^{-5}) \\ &= (3.4)(61) \times (10^5)(10^{-5}) \\ &= 207.4 \times 10^0 \\ &= \mathbf{207.4} \end{aligned}$$

---

**Division** In general,

$$\frac{A \times 10^n}{B \times 10^m} = \frac{A}{B} \times 10^{n-m} \quad (1.8)$$

revealing again that the *operations with the power of ten can be separated from the same operation with the multipliers.*

Eq. (1.8) states

**when dividing numbers in the power-of-ten format, first find the result of dividing the multipliers. Then determine the associated power for the result by subtracting the power of ten of the denominator from the power of ten of the numerator.**

---

**EXAMPLE 1.10**

$$\begin{aligned} \text{a. } \frac{0.00047}{0.002} &= \frac{47 \times 10^{-5}}{2 \times 10^{-3}} = \left(\frac{47}{2}\right) \times \left(\frac{10^{-5}}{10^{-3}}\right) = 23.5 \times 10^{-2} \\ \text{b. } \frac{690,000}{0.00000013} &= \frac{69 \times 10^4}{13 \times 10^{-8}} = \left(\frac{69}{13}\right) \times \left(\frac{10^4}{10^{-8}}\right) = 5.31 \times 10^{12} \end{aligned}$$

---

**Powers** In general,

$$(A \times 10^n)^m = A^m \times 10^{nm} \quad (1.9)$$

which again permits the separation of the *operation with the power of ten from the multiplier.*

Eq. (1.9) states

**when finding the power of a number in the power-of-ten format, first separate the multiplier from the power of ten and determine each separately. Determine the power-of-ten component by multiplying the power of ten by the power to be determined.**

---

**EXAMPLE 1.11**

$$\begin{aligned} \text{a. } (0.00003)^3 &= (3 \times 10^{-5})^3 = (3)^3 \times (10^{-5})^3 \\ &= 27 \times 10^{-15} \\ \text{b. } (90,800,000)^2 &= (9.08 \times 10^7)^2 = (9.08)^2 \times (10^7)^2 \\ &= 82.45 \times 10^{14} \end{aligned}$$

---

In particular, remember that the following operations are not the same. One is the product of two numbers in the power-of-ten format, while the other is a number in the power-of-ten format taken to a power. As noted below, the results of each are quite different:

$$\begin{aligned} (10^3)(10^3) &\neq (10^3)^3 \\ (10^3)(10^3) &= 10^6 = 1,000,000 \\ (10^3)^3 &= (10^3)(10^3)(10^3) = 10^9 = 1,000,000,000 \end{aligned}$$

## 1.7 FIXED-POINT, FLOATING-POINT, SCIENTIFIC, AND ENGINEERING NOTATION

When you are using a computer or a calculator, numbers generally appear in one of four ways. If powers of ten are not employed, numbers are written in the **fixed-point** or **floating-point notation**.

*The fixed-point format requires that the decimal point appear in the same place each time. In the floating-point format, the decimal point appears in a location defined by the number to be displayed.*

Most computers and calculators permit a choice of fixed- or floating-point notation. In the fixed format, the user can choose the level of accuracy for the output as tenths place, hundredths place, thousandths place, and so on. Every output will then fix the decimal point to one location, such as the following examples using thousandths-place accuracy:

$$\frac{1}{3} = 0.333 \quad \frac{1}{16} = 0.063 \quad \frac{2300}{2} = 1150.000$$

If left in the floating-point format, the results will appear as follows for the above operations:

$$\frac{1}{3} = 0.333333333333 \quad \frac{1}{16} = 0.0625 \quad \frac{2300}{2} = 1150$$

Powers of ten will creep into the fixed- or floating-point notation if the number is too small or too large to be displayed properly.

**Scientific (also called *standard*) notation and engineering notation** make use of powers of ten, with restrictions on the mantissa (multiplier) or scale factor (power of ten).

*Scientific notation requires that the decimal point appear directly after the first digit greater than or equal to 1 but less than 10.*

A power of ten will then appear with the number (usually following the power notation E), even if it has to be to the zero power. A few examples:

$$\frac{1}{3} = 3.333333333333\text{E}-1 \quad \frac{1}{16} = 6.25\text{E}-2 \quad \frac{2300}{2} = 1.15\text{E}3$$

Within scientific notation, the fixed- or floating-point format can be chosen. In the above examples, floating was employed. If fixed is chosen and set at the hundredths-point accuracy, the following will result for the above operations:

$$\frac{1}{3} = 3.33\text{E}-1 \quad \frac{1}{16} = 6.25\text{E}-2 \quad \frac{2300}{2} = 1.15\text{E}3$$

**Engineering notation** specifies that

*all powers of ten must be 0 or multiples of 3, and the mantissa must be greater than or equal to 1 but less than 1000.*

This restriction on the powers of ten is because specific powers of ten have been assigned prefixes that are introduced in the next few paragraphs.

Using scientific notation in the floating-point mode results in the following for the above operations:

$$\frac{1}{3} = 333.3333333333\text{E}-3 \quad \frac{1}{16} = 62.5\text{E}-3 \quad \frac{2300}{2} = 1.15\text{E}3$$

Using engineering notation with two-place accuracy will result in the following:

$$\frac{1}{3} = 333.33\text{E}-3 \quad \frac{1}{16} = 62.50\text{E}-3 \quad \frac{2300}{2} = 1.15\text{E}3$$

## Prefixes

Specific powers of ten in engineering notation have been assigned prefixes and symbols, as appearing in Table 1.2. They permit easy recognition of the power of ten and an improved channel of communication between technologists.

TABLE 1.2

Multiplication Factors	SI Prefix	SI Symbol
1000 000 000 000 000 000 = $10^{18}$	exa	E
1 000 000 000 000 000 = $10^{15}$	peta	P
1 000 000 000 000 = $10^{12}$	tera	T
1 000 000 000 = $10^9$	giga	G
1 000 000 = $10^6$	mega	M
1 000 = $10^3$	kilo	k
0.001 = $10^{-3}$	milli	m
0.000 001 = $10^{-6}$	micro	$\mu$
0.000 000 001 = $10^{-9}$	nano	n
0.000 000 000 001 = $10^{-12}$	pico	p
0.000 000 000 000 001 = $10^{-15}$	femto	f
0.000 000 000 000 000 001 = $10^{-18}$	atto	a

### EXAMPLE 1.12

- 1,000,000 ohms =  $1 \times 10^6$  ohms  
= **1 megohm = 1 M $\Omega$**
- 100,000 meters =  $100 \times 10^3$  meters  
= **100 kilometers = 100 km**
- 0.0001 second =  $0.1 \times 10^{-3}$  second  
= **0.1 millisecond = 0.1 ms**
- 0.000001 farad =  $1 \times 10^{-6}$  farad  
= **1 microfarad = 1  $\mu$ F**

Here are a few examples with numbers that are not strictly powers of ten.

**EXAMPLE 1.13**

- a. 41,200 m is equivalent to  $41.2 \times 10^3 \text{ m} = 41.2 \text{ kilometers} = \mathbf{41.2 \text{ km}}$ .
- b. 0.00956 J is equivalent to  $9.56 \times 10^{-3} \text{ J} = 9.56 \text{ millijoules} = \mathbf{9.56 \text{ mJ}}$ .
- c. 0.000768 s is equivalent to  $768 \times 10^{-6} \text{ s} = 768 \text{ microseconds} = \mathbf{768 \mu\text{s}}$ .
- d.  $\frac{8400 \text{ m}}{0.06} = \frac{8.4 \times 10^3 \text{ m}}{6 \times 10^{-2}} = \left(\frac{8.4}{6}\right) \times \left(\frac{10^3}{10^{-2}}\right) \text{ m}$   
 $= 1.4 \times 10^5 \text{ m} = 140 \times 10^3 \text{ m}$   
 $= 140 \text{ kilometers} = \mathbf{140 \text{ km}}$
- e.  $(0.0003)^4 \text{ s} = (3 \times 10^{-4})^4 \text{ s} = 81 \times 10^{-16} \text{ s}$   
 $= 0.0081 \times 10^{-12} \text{ s} = 0.0081 \text{ picosecond}$   
 $= \mathbf{0.0081 \text{ ps}}$

**1.8 CONVERSION BETWEEN LEVELS OF POWERS OF TEN**

It is often necessary to convert from one power of ten to another. For instance, if a meter measures kilohertz (kHz—a unit of measurement for the frequency of an ac waveform), it may be necessary to find the corresponding level in megahertz (MHz). If time is measured in milliseconds (ms), it may be necessary to find the corresponding time in microseconds ( $\mu\text{s}$ ) for a graphical plot. The process is not difficult if we simply keep in mind that an increase or a decrease in the power of ten must be associated with the opposite effect on the multiplying factor. The procedure is best described by the following steps:

1. *Replace the prefix by its corresponding power of ten.*
2. *Rewrite the expression, and set it equal to an unknown multiplier and the new power of ten.*
3. *Note the change in power of ten from the original to the new format. If it is an increase, move the decimal point of the original multiplier to the left (smaller value) by the same number. If it is a decrease, move the decimal point of the original multiplier to the right (larger value) by the same number.*

**EXAMPLE 1.14** Convert 20 kHz to megahertz.

**Solution:** In the power-of-ten format:

$$20 \text{ kHz} = 20 \times 10^3 \text{ Hz}$$

The conversion requires that we find the multiplying factor to appear in the space below:

$$20 \times 10^3 \text{ Hz} \Rightarrow \underline{\quad} \times 10^6 \text{ Hz}$$

Increase by 3
Decrease by 3

Since the power of ten will be *increased* by a factor of *three*, the multiplying factor must be *decreased* by moving the decimal point *three* places to the left, as shown below:

$$\underbrace{020}_3 = 0.02$$

and  $20 \times 10^3 \text{ Hz} = 0.02 \times 10^6 \text{ Hz} = \mathbf{0.02 \text{ MHz}}$

**EXAMPLE 1.15** Convert 0.01 ms to microseconds.

**Solution:** In the power-of-ten format:

$$0.01 \text{ ms} = 0.01 \times 10^{-3} \text{ s}$$

and

$$0.01 \times 10^{-3} \text{ s} \Rightarrow \underline{\quad} \times 10^{-6} \text{ s}$$

Decrease by 3  
Increase by 3

Since the power of ten will be *reduced* by a factor of three, the multiplying factor must be *increased* by moving the decimal point three places to the right, as follows:

$$0.010 = 10$$

and  $0.01 \times 10^{-3} \text{ s} = 10 \times 10^{-6} \text{ s} = \mathbf{10 \mu\text{s}}$

There is a tendency when comparing  $-3$  to  $-6$  to think that the power of ten has increased, but keep in mind when making your judgment about increasing or decreasing the magnitude of the multiplier that  $10^{-6}$  is a great deal smaller than  $10^{-3}$ .

**EXAMPLE 1.16** Convert 0.002 km to millimeters.

**Solution:**

$$0.002 \times 10^3 \text{ m} \Rightarrow \underline{\quad} \times 10^{-3} \text{ m}$$

Decrease by 6  
Increase by 6

In this example we have to be very careful because the difference between  $+3$  and  $-3$  is a factor of 6, requiring that the multiplying factor be modified as follows:

$$\underbrace{0.002000}_6 = 2000$$

and  $0.002 \times 10^3 \text{ m} = 2000 \times 10^{-3} \text{ m} = \mathbf{2000 \text{ mm}}$

## 1.9 CONVERSION WITHIN AND BETWEEN SYSTEMS OF UNITS

The conversion within and between systems of units is a process that cannot be avoided in the study of any technical field. It is an operation, however, that is performed incorrectly so often that this section was included to provide one approach that, if applied properly, will lead to the correct result.

There is more than one method of performing the conversion process. In fact, some people prefer to determine mentally whether the conversion factor is multiplied or divided. This approach is acceptable for some elementary conversions, but it is risky with more complex operations.

The procedure to be described here is best introduced by examining a relatively simple problem such as converting inches to meters. Specifically, let us convert 48 in. (4 ft) to meters.

If we multiply the 48 in. by a factor of **1**, the magnitude of the quantity remains the same:

$$48 \text{ in.} = 48 \text{ in.}(\mathbf{1}) \quad (1.10)$$

Let us now look at the conversion factor for this example:

$$1 \text{ m} = 39.37 \text{ in.}$$

Dividing both sides of the conversion factor by 39.37 in. results in the following format:

$$\frac{1 \text{ m}}{39.37 \text{ in.}} = (\mathbf{1})$$

Note that the end result is that the ratio 1 m/39.37 in. equals 1, as it should since they are equal quantities. If we now substitute this factor (**1**) into Eq. (1.10), we obtain

$$48 \text{ in.}(\mathbf{1}) = 48 \text{ in.} \left( \frac{1 \text{ m}}{39.37 \text{ in.}} \right)$$

which results in the cancellation of inches as a unit of measure and leaves meters as the unit of measure. In addition, since the 39.37 is in the denominator, it must be divided into the 48 to complete the operation:

$$\frac{48}{39.37} \text{ m} = \mathbf{1.219 \text{ m}}$$

Let us now review the method:

- 1. Set up the conversion factor to form a numerical value of (1) with the unit of measurement to be removed from the original quantity in the denominator.**
- 2. Perform the required mathematics to obtain the proper magnitude for the remaining unit of measurement.**

---

**EXAMPLE 1.17** Convert 6.8 min to seconds.

**Solution:** The conversion factor is

$$1 \text{ min} = 60 \text{ s}$$

Since the minute is to be removed as the unit of measurement, it must appear in the denominator of the (**1**) factor, as follows:

$$\text{Step 1:} \quad \left( \frac{60 \text{ s}}{1 \text{ min}} \right) = \mathbf{(1)}$$

$$\begin{aligned} \text{Step 2:} \quad 6.8 \text{ min}(\mathbf{1}) &= 6.8 \cancel{\text{ min}} \left( \frac{60 \text{ s}}{1 \cancel{\text{ min}}} \right) = (6.8)(60) \text{ s} \\ &= \mathbf{408 \text{ s}} \end{aligned}$$

**EXAMPLE 1.18** Convert 0.24 m to centimeters.

**Solution:** The conversion factor is

$$1 \text{ m} = 100 \text{ cm}$$

Since the meter is to be removed as the unit of measurement, it must appear in the denominator of the **(1)** factor as follows:

$$\text{Step 1:} \quad \left( \frac{100 \text{ cm}}{1 \text{ m}} \right) = \mathbf{1}$$

$$\begin{aligned} \text{Step 2:} \quad 0.24 \text{ m}(\mathbf{1}) &= 0.24 \cancel{\text{ m}} \left( \frac{100 \text{ cm}}{1 \cancel{\text{ m}}} \right) = (0.24)(100) \text{ cm} \\ &= \mathbf{24 \text{ cm}} \end{aligned}$$

The products **(1)(1)** and **(1)(1)(1)** are still **1**. Using this fact, we can perform a series of conversions in the same operation.

**EXAMPLE 1.19** Determine the number of minutes in half a day.

**Solution:** Working our way through from days to hours to minutes, always ensuring that the unit of measurement to be removed is in the denominator, results in the following sequence:

$$\begin{aligned} 0.5 \cancel{\text{ day}} \left( \frac{24 \cancel{\text{ h}}}{1 \cancel{\text{ day}}} \right) \left( \frac{60 \text{ min}}{1 \cancel{\text{ h}}} \right) &= (0.5)(24)(60) \text{ min} \\ &= \mathbf{720 \text{ min}} \end{aligned}$$

**EXAMPLE 1.20** Convert 2.2 yards to meters.

**Solution:** Working our way through from yards to feet to inches to meters results in the following:

$$\begin{aligned} 2.2 \cancel{\text{ yards}} \left( \frac{3 \cancel{\text{ ft}}}{1 \cancel{\text{ yard}}} \right) \left( \frac{12 \cancel{\text{ in.}}}{1 \cancel{\text{ ft}}} \right) \left( \frac{1 \text{ m}}{39.37 \cancel{\text{ in.}}} \right) &= \frac{(2.2)(3)(12)}{39.37} \text{ m} \\ &= \mathbf{2.012 \text{ m}} \end{aligned}$$

The following examples are variations of the above in practical situations.

**EXAMPLE 1.21** In Europe, Canada, and many other countries, the speed limit is posted in kilometers per hour. How fast in miles per hour is 100 km/h?

**Solution:**

$$\begin{aligned} & \left(\frac{100 \text{ km}}{\text{h}}\right)(1)(1)(1)(1) \\ &= \left(\frac{100 \cancel{\text{km}}}{\text{h}}\right)\left(\frac{1000 \cancel{\text{m}}}{1 \cancel{\text{km}}}\right)\left(\frac{39.37 \cancel{\text{in.}}}{1 \cancel{\text{m}}}\right)\left(\frac{1 \cancel{\text{ft}}}{12 \cancel{\text{in.}}}\right)\left(\frac{1 \text{ mi}}{5280 \cancel{\text{ft}}}\right) \\ &= \frac{(100)(1000)(39.37) \text{ mi}}{(12)(5280) \text{ h}} \\ &= \mathbf{62.14 \text{ mph}} \end{aligned}$$

Many travelers use 0.6 as a conversion factor to simplify the math involved; that is,

$$(100 \text{ km/h})(0.6) \cong 60 \text{ mph}$$

and

$$(60 \text{ km/h})(0.6) \cong 36 \text{ mph}$$

**EXAMPLE 1.22** Determine the speed in miles per hour of a competitor who can run an amazing 4-min mile.

**Solution:** Inverting the factor 4 min/1 mi to 1 mi/4 min, we can proceed as follows:

$$\left(\frac{1 \text{ mi}}{4 \cancel{\text{min}}}\right)\left(\frac{60 \cancel{\text{min}}}{4}\right) = \frac{60}{4} \text{ mi/h} = \mathbf{15 \text{ mph}}$$

**TABLE 1.3**

Symbol	Meaning
$\neq$	Not equal to $6.12 \neq 6.13$
$>$	Greater than $4.78 > 4.20$
$\gg$	Much greater than $840 \gg 16$
$<$	Less than $430 < 540$
$\ll$	Much less than $0.002 \ll 46$
$\geq$	Greater than or equal to $x \geq y$ is satisfied for $y = 3$ and $x > 3$ or $x = 3$
$\leq$	Less than or equal to $x \leq y$ is satisfied for $y = 3$ and $x < 3$ or $x = 3$
$\cong$	Approximately equal to $3.14159 \cong 3.14$
$\Sigma$	Sum of $\Sigma(4 + 6 + 8) = 18$
$\ $	Absolute magnitude of $ a  = 4$ , where $a = -4$ or $+4$
$\therefore$	Therefore $x = \sqrt{4} \therefore x = \pm 2$
$\equiv$	By definition Establishes a relationship between two or more quantities
$a:b$	Ratio defined by $\frac{a}{b}$
$a:b = c:d$	Proportion defined by $\frac{a}{b} = \frac{c}{d}$

**1.10 SYMBOLS**

Throughout the text, various symbols will be employed that you may not have had occasion to use. Some are defined in Table 1.3, and others will be defined in the text as the need arises.

**1.11 CONVERSION TABLES**

Conversion tables such as those appearing in Appendix A can be very useful when time does not permit the application of methods described in this chapter. However, even though such tables appear easy to use, frequent errors occur because the operations appearing at the head of the table are not performed properly. In any case, when using such tables, try to establish mentally some order of magnitude for the quantity to be determined compared to the magnitude of the quantity in its original set of units. This simple operation should prevent several impossible results that may occur if the conversion operation is improperly applied.

For example, consider the following from such a conversion table:

<u>To convert from</u>	<u>To</u>	<u>Multiply by</u>
Miles	Meters	$1.609 \times 10^3$

A conversion of 2.5 mi to meters would require that we multiply 2.5 by the conversion factor; that is,

$$2.5 \text{ mi}(1.609 \times 10^3) = \mathbf{4.02 \times 10^3 \text{ m}}$$

A conversion from 4000 m to miles would require a division process:

$$\frac{4000 \text{ m}}{1.609 \times 10^3} = 2486.02 \times 10^{-3} = \mathbf{2.49 \text{ mi}}$$

In each of the above, there should have been little difficulty realizing that 2.5 mi would convert to a few thousand meters and 4000 m would be only a few miles. As indicated above, this kind of anticipatory thinking will eliminate the possibility of ridiculous conversion results.

## 1.12 CALCULATORS

In most texts, the calculator is not discussed in detail. Instead, students are left with the general exercise of choosing an appropriate calculator and learning to use it properly on their own. However, some discussion about the use of the calculator is needed to eliminate some of the impossible results obtained (and often strongly defended by the user—because the calculator says so) through a correct understanding of the process by which a calculator performs the various tasks. Time and space do not permit a detailed explanation of all the possible operations, but the following discussion explains why it is important to understand how a calculator proceeds with a calculation and that the unit cannot accept data in any form and still generate the correct answer.

### TI-89 Calculator

Although the calculator chosen for this text is one of the more expensive, a great deal of thought went into its choice. The TI-89 Titanium model calculator (Fig. 1.5) was used in the previous edition and, before preparing the manuscript for this 13th edition, a study was made of the calculators available today. In all honesty, some of the cheapest calculators on the market can perform the necessary functions required in this text. However, the time it will take to perform some of the basic operations required in the ac section of this text may result in a high level of frustration because it takes so long to do a simple analysis. The TI-89 has the ability to significantly reduce the time required and number of operations needed to complete the same analysis and, therefore, was chosen for this edition also. However, it is certainly possible that your instructor is recommending a different calculator for the course or your chosen field. In such situations there is no doubt your professor has balanced the needs of the course with the financial obligations you face and has suggested a calculator that will perform very well.

For those using the TI-89 calculator, there will be times when it seems to require more steps than you expected to perform a simple task. However, be assured that as you work through the content of this text you will be very pleased with the performance of the calculator. Bear in mind that the TI-89 has capabilities that could be very helpful in other areas of study such as mathematics and physics. In addition, it is tool that will serve you well not only in your college years but in your future career as well.

When using any calculator for the first time, the unit must be set up to provide the answers in a desired format. Following are the steps needed to set up the TI-89 calculator correctly.

**Initial Settings** In the following sequences, the arrows within the square indicate the direction of the scrolling required to reach the desired location. The scrolling may continue for a number of levels but eventually the desired heading will appear on the screen.



**FIG. 1.5**  
*Texas Instruments  
Titanium TI-89 calculator.*  
(Don Johnson Photo)

**Notation** The first sequence sets the **engineering notation** (Section 1.7) as the choice for all answers. It is particularly important to take note that you must select the ENTER key twice to ensure the process is set in memory.

ON HOME MODE  $\downarrow$  Exponential Format  $\rightarrow \downarrow$   
ENGINEERING ENTER ENTER

**Accuracy Level** Next, the accuracy level can be set to two places as follows:

MODE  $\downarrow$  Display Digits  $\rightarrow \downarrow$  3:FIX 2 ENTER ENTER

**Approximate Mode** For all solutions, the solution should be in decimal form to second-place accuracy. If this is not set, some answers will appear in fractional form to ensure the answer is EXACT (another option). This selection is made with the following sequence:

MODE F2  $\downarrow$  Exact/Approx  $\rightarrow \downarrow$  3: APPROXIMATE ENTER ENTER

**Clear Screen** To clear the screen of all entries and results, use the following sequence:

F1  $\downarrow$  8: Clear Home ENTER

**Clear Current Entries** To delete the sequence of current entries at the bottom of the screen, select the CLEAR key.

**Turn Off** To turn off the calculator, apply the following sequence:

2ND ON

## Calculator Fundamentals

**Order of Operations** Although setting the correct format and accurate input is important, improper results occur primarily because users fail to realize that no matter how simple or complex an equation, the calculator performs the required operations in a specific order.

This is a fact that is true for any calculator you may use. The content below is for the majority of commercially available calculators.

Consider the operation

$$\frac{8}{3 + 1}$$

which is often entered as

$$8 \div 3 + 1 \text{ ENTER} = \frac{8}{3} + 1 = 2.67 + 1 = 3.67$$

This is incorrect (2 is the answer).

The calculator *will not* perform the addition first and then the division. In fact, addition and subtraction are the last operations to be performed in any equation. It is therefore very important that you carefully study and thoroughly understand the next few paragraphs in order to use the calculator properly.

**1. The first operations to be performed by a calculator can be set using parentheses (). It does not matter which operations are within the parentheses. The parentheses simply**

dictate that this part of the equation is to be determined first. There is no limit to the number of parentheses in each equation—all operations within parentheses will be performed first. For instance, for the example above, if parentheses are added as shown below, the addition will be performed first and the correct answer obtained:

$$\frac{8}{(3 + 1)} = \boxed{8} \boxed{\div} \boxed{(} \boxed{3} \boxed{+} \boxed{1} \boxed{)} \boxed{\text{ENTER}} \\ = 2.00$$

2. Next, powers and roots are performed, such as  $x^2$ ,  $\sqrt{x}$ , and so on.
3. Negation (applying a negative sign to a quantity) and single-key operations such as  $\sin$ ,  $\tan^{-1}$ , and so on, are performed.
4. Multiplication and division are then performed.
5. Addition and subtraction are performed last.

It may take a few moments and some repetition to remember the order, but at least you are now aware that there is an order to the operations and that ignoring them can result in meaningless results.

---

**EXAMPLE 1.23** Determine

$$\sqrt{\frac{9}{3}}$$

**Solution:**

$$\boxed{2\text{ND}} \boxed{\sqrt{\phantom{x}}} \boxed{(} \boxed{9} \boxed{\div} \boxed{3} \boxed{)} \boxed{\text{ENTER}} = 1.73$$

In this case, the left bracket is automatically entered after the square root sign. The right bracket must then be entered before performing the calculation.

For all calculator operations, the number of right brackets must always equal the number of left brackets.

---

**EXAMPLE 1.24** Find

$$\frac{3 + 9}{4}$$

**Solution:** If the problem is entered as it appears, the *incorrect answer* of 5.25 will result.

$$\boxed{3} \boxed{+} \boxed{9} \boxed{\div} \boxed{4} \boxed{\text{ENTER}} = 3 + \frac{9}{4} = 5.25$$

Using brackets to ensure that the addition takes place before the division will result in the correct answer as shown below:

$$\boxed{(} \boxed{3} \boxed{+} \boxed{9} \boxed{)} \boxed{\div} \boxed{4} \boxed{\text{ENTER}} \\ = \frac{(3 + 9)}{4} = \frac{12}{4} = 3.00$$

---

**EXAMPLE 1.25** Determine

$$\frac{1}{4} + \frac{1}{6} + \frac{2}{3}$$

**Solution:** Since the division will occur first, the correct result will be obtained by simply performing the operations as indicated. That is,

$$\boxed{1} \boxed{\div} \boxed{4} \boxed{+} \boxed{1} \boxed{\div} \boxed{6} \boxed{+} \boxed{2} \boxed{\div} \boxed{3} \boxed{\text{ENTER}} = \frac{1}{4} + \frac{1}{6} + \frac{2}{3} = 1.08$$

**Powers of Ten** The  $\boxed{\text{EE}}$  key is used to set the power of ten of a number. Setting up the number  $2200 = 2.2 \times 10^3$  requires the following keypad selections:

$$\boxed{2} \boxed{\cdot} \boxed{2} \boxed{\text{EE}} \boxed{3} \boxed{\text{ENTER}} = 2.20\text{E}3$$

Setting up the number  $8.2 \times 10^{-6}$  requires the negative sign ( $-$ ) from the *numerical keypad*. Do not use the negative sign from the mathematical listing of  $\div$ ,  $\times$ ,  $-$ , and  $+$ . That is,

$$\boxed{8} \boxed{\cdot} \boxed{2} \boxed{\text{EE}} \boxed{(-)} \boxed{6} \boxed{\text{ENTER}} = 8.20\text{E}-6$$

**EXAMPLE 1.26** Perform the addition  $6.3 \times 10^3 + 75 \times 10^3$  and compare your answer with the longhand solution of Example 1.8(a).

**Solution:**

$$\boxed{6} \boxed{\cdot} \boxed{3} \boxed{\text{EE}} \boxed{3} \boxed{+} \boxed{7} \boxed{5} \boxed{\text{EE}} \boxed{3} \boxed{\text{ENTER}} = 81.30\text{E}3$$

which confirms the results of Example 1.8(a).

**EXAMPLE 1.27** Perform the division  $(69 \times 10^4)/(13 \times 10^{-8})$  and compare your answer with the longhand solution of Example 1.10(b).

**Solution:**

$$\boxed{6} \boxed{9} \boxed{\text{EE}} \boxed{4} \boxed{\div} \boxed{1} \boxed{3} \boxed{\text{EE}} \boxed{(-)} \boxed{8} \boxed{\text{ENTER}} = 5.31\text{E}12$$

which confirms the results of Example 1.10(b).

**EXAMPLE 1.28** Using the provided format of each number, perform the following calculation in one series of keypad entries:

$$\frac{(0.004)(6 \times 10^{-4})}{(2 \times 10^{-3})^2} = ?$$

**Solution:**

$$\boxed{(} \boxed{(} \boxed{0} \boxed{\cdot} \boxed{0} \boxed{0} \boxed{4} \boxed{)} \boxed{\times} \boxed{(} \boxed{6} \boxed{\text{EE}} \boxed{(-)} \boxed{4} \boxed{)} \boxed{)} \boxed{\div} \boxed{2} \boxed{\text{EE}} \boxed{(-)} \boxed{3} \boxed{\wedge} \boxed{2} \boxed{\text{ENTER}} = 600.00\text{E}-3 = 0.6$$

Brackets were used to ensure that the calculations were performed in the correct order. Note also that the number of left brackets equals the number of right brackets.

## 1.13 COMPUTER ANALYSIS

There is no question that a basic knowledge of computer methods is something that the graduating student must learn in an educational program. Industry now requires students to be proficient in the use of a computer.

Two general directions can be taken to develop the necessary computer skills: the study of computer languages or the use of software packages.

### Languages

There are several languages that provide a direct line of communication with the computer and the operations it can perform. A **language** is a set of symbols, letters, words, or statements that the user can enter into the computer. The computer system will “understand” these entries and will perform them in the order established by a series of commands called a **program**. The program tells the computer what to do on a sequential, line-by-line basis in the same order a student would perform the calculations in longhand. The computer can respond only to the commands entered by the user. This requires that the programmer understand fully the sequence of operations and calculations required to obtain a particular solution. A lengthy analysis can result in a program having hundreds or thousands of lines. Once written, the program must be checked carefully to ensure that the results have meaning and are valid for an expected range of input variables. Some of the popular languages applied in the electrical/electronics field today include C++, QBASIC, Java, and FORTRAN. Each has its own set of commands and statements to communicate with the computer, but each can be used to perform the same type of analysis.

### Software Packages

The second approach to computer analysis—**software packages**—avoids the need to know a particular language; in fact, the user may not be aware of which language was used to write the programs within the package. All that is required is a knowledge of how to input the network parameters, define the operations to be performed, and extract the results; the package will do the rest. However, there is a problem with using packaged programs without understanding the basic steps the program uses. You can obtain a solution without the faintest idea of either how the solution was obtained or whether the results are valid or way off base. It is imperative that you realize that the computer should be used as a tool to assist the user—it must not be allowed to control the scope and potential of the user!

Each software package has a **menu**, which defines the range of application of the package. Once the software is entered into the computer, the system will perform all the functions appearing in the menu, as it was preprogrammed to do. Be aware, however, that if a particular type of analysis is requested that is not on the menu, the software package cannot provide the desired results. The package is limited solely to those maneuvers developed by the team of programmers who developed the software package. In such situations the user must turn to another software package or write a program using one of the languages listed above.

In broad terms, if a software package is available to perform a particular analysis, then that package should be used rather than developing new routines. Most popular software packages are the result of many hours of effort by teams of programmers with years of experience. However, if the results are not in the desired format, or if the software package does not provide all the desired results, then the user's innovative talents should be put to use to develop a software package. As noted above, any program the user writes that passes the tests of range and accuracy can be considered a software package of his or her authorship for future use.

## PROBLEMS

Note: More difficult problems are denoted by an asterisk (\*) throughout the text.

### SECTION 1.2 A Brief History

1. Visit your local library (at school or home) and describe the extent to which it provides literature and computer support for the technologies—in particular, electricity, electronics, electromagnetics, and computers.
2. Choose an area of particular interest in this field and write a very brief report on the history of the subject.
3. Choose an individual of particular importance in this field and write a very brief review of his or her life and important contributions.

### SECTION 1.3 Units of Measurement

4. **a.** In a recent Tour de France time trial, a participant traveled 60.5 mi in a time trial in 2 h, 15 min. What was his average speed in mph?  
**b.** What is the speed in km/h?
5. In most countries outside the United States speed is measured in kilometers per hour (km/h) rather than miles per hour (mph). Although the exact conversion from km/h to mph is 0.57, a conversion factor of 0.6 is generally used because it is easier to remember. For the reverse conversion a factor of 1.7 is normally used. Perform the following conversions using the approximate conversion factors.
  - a.** What is the speed in mph of an automobile on the German Autobahn traveling at 160 km/h?
  - b.** What is the speed in km/h of a motorcycle traveling at 70 mph in the United States?
6. How long in seconds will it take a car traveling at 80 mph to travel the length of a football field (100 yd)?
- \*7. A pitcher has the ability to throw a baseball at 95 mph.
  - a.** How fast is the speed in ft/s?
  - b.** How long does the hitter have to make a decision about swinging at the ball if the plate and the mound are separated by 60 ft?
  - c.** If the batter wanted a full second to make a decision, what would the speed in mph have to be?

### SECTION 1.4 Systems of Units

8. Are there any relative advantages associated with the metric system compared to the English system with respect to length, mass, force, and temperature? If so, explain.
9. Which of the four systems of units appearing in Table 1.1 has the smallest units for length, mass, and force? When would this system be used most effectively?
- \*10. Which system of Table 1.1 is closest in definition to the SI system? How are the two systems different? Why do you think the units of measurement for the SI system were chosen as listed in Table 1.1? Give the best reasons you can without referencing additional literature.
11. What is room temperature (23°C) in the English and SI systems?
12. How many foot-pounds of energy are associated with 4000 J?
13. In Europe the height of a man or woman is measured in centimeters and his or her weight in kilograms.
  - a.** What is the weight in pounds (lb) of a man who weighs 70.8 kg?
  - b.** What is the weight in kg of a woman who weighs 145 lb?
  - c.** What is the height of a man in cm who is 6 ft tall?
  - d.** In Norway, the average height of a man is 179.9 cm. What is his height in feet and inches?
14. Throughout the world, the majority of countries use the centigrade scale rather than the Fahrenheit scale. This can cause problems for travelers not familiar with what to expect at certain temperature levels. To alleviate this problem, the following **approximate** conversion is typically used:

$$^{\circ}\text{F} = 2(^{\circ}\text{C}) + 30^{\circ}$$

Comparing to the exact formula of  $^{\circ}\text{F} = \frac{9}{5}^{\circ}\text{C} + 32^{\circ}$ , we

find the ratio 9/5 is approximated to equal 2, and the temperature of 32° is changed to 30° simply to make the numbers easier to work with and slightly compensate for the fact that 2(°C) is more than 9/5(°C).

- a.** The temperature of 20°C is commonly accepted as normal room temperature. Using the approximate formula, determine (in your head) the equivalent Fahrenheit temperature.

- b. Use the exact formula and determine the equivalent Fahrenheit temperature for 20°C.  
 c. How do the results of parts (a) and (b) compare? Is the approximation valid as a first estimate of the Fahrenheit temperature?  
 d. Repeat parts (a) and (b) for a high temperature of 30°C and a low temperature of 5°C.

### SECTION 1.5 Significant Figures, Accuracy, and Rounding Off

15. Write the following numbers to tenths-place accuracy.  
 a. 14.6026                      b. 056.0420  
 c. 1,046.06                     d. 1/16  
 e.  $\pi$
16. Repeat Problem 15 using hundredths-place accuracy.  
 17. Repeat Problem 15 using thousandths-place accuracy.

### SECTION 1.6 Powers of Ten

18. Express the following numbers as powers of ten to hundredths-place accuracy:  
 a. 10,000                         b. 1,000,000  
 c. 1000                            d. 0.001  
 e. 1                                 f. 0.1
19. Using only those powers of ten listed in Table 1.2, express the following numbers in what seems to you the most logical form for future calculations:  
 a. 15,000                         b. 0.005  
 c. 2,400,000                     d. 60,000  
 e. 0.00040200                   f. 0.0000000002
20. Perform the following operations to hundredths-place accuracy:  
 a.  $4300 + 47,000$   
 b.  $8 \times 10^4 + 4.6 \times 10^5$   
 c.  $0.6 \times 10^{-3} - 6 \times 10^{-6}$   
 d.  $2.6 \times 10^3 + 60,000 \times 10^{-3} - 500$
21. Perform the following operations:  
 a.  $(1000)(10000)$                 b.  $(0.001)(100)$   
 c.  $(10^2)(10^7)$                      d.  $(100)(0.000001)$   
 e.  $(10^{-8})(10,000,000)$         f.  $(10,000)(10^{-10})(10^{26})$
22. Perform the following operations to hundredths-place accuracy:  
 a.  $(20,000)(0.003)$   
 b.  $8150 \times 0.001$   
 c.  $(0.000059)(2.2 \times 10^5)$   
 d.  $(21 \times 10^{-4})(0.03)(5 \times 10^7)$
23. Perform the following operations:  
 a.  $\frac{100}{10,000}$                             b.  $\frac{0.010}{1000}$   
 c.  $\frac{10,000}{0.001}$                             d.  $\frac{0.0000001}{100}$   
 e.  $\frac{10^{38}}{0.000100}$                         f.  $\frac{(100)^{1/2}}{0.01}$

24. Perform the following operations to hundredths-place accuracy:

a. $\frac{4000}{0.00008}$	b. $\frac{0.006}{6 \times 10^6}$
c. $\frac{0.000440}{0.00005}$	d. $\frac{88 \times 10^{18}}{8 \times 10^{-8}}$

25. Perform the following operations:

a. $(100)^3$	b. $(0.0001)^{1/2}$
c. $(10,000)^8$	d. $(0.00000010)^9$

26. Perform the following operations to hundredths-place accuracy:

a. $(400)^2$
b. $(6 \times 10^{-4})^4$
c. $(0.005)(3 \times 10^{-4})^2$
d. $[(2 \times 10^{-4})(0.8 \times 10^5)(0.0005 \times 10^6)]^3$

27. Perform the following operations to hundredths-place accuracy:

a. $\frac{(300)^2(100)}{3 \times 10^4}$	b. $[(40,000)^2][(20)^{-3}]$
c. $\frac{(60,000)^2}{(0.02)^2}$	d. $\frac{(0.000027)^{1/3}}{200,000}$
e. $\frac{[(4000)^2][300]}{2 \times 10^{-4}}$	
f. $[(0.000016)^{1/2}][(100,000)^5][0.02]$	
*g. $\frac{[(0.003)^3][0.00007]^{-2}[(160)^2]}{[(200)(0.0008)]^{-1/2}}$ (a challenge)	

### SECTION 1.7 Fixed-Point, Floating-Point, Scientific, and Engineering Notation

28. Write the following numbers in scientific and engineering notation to hundredths place:  
 a. 20.46                            b. 50,420  
 c. 0.000674                      d. 000.0460
29. Write the following numbers in scientific and engineering notation to tenths place:  
 a.  $5 \times 10^{-2}$   
 b.  $0.45 \times 10^{+2}$   
 c. 1/32  
 d.  $\pi$
30. Perform the following operations and leave the answer in engineering notation:  
 a.  $(8 \times 10^{-3})(4 \times 10^5) =$   
 b.  $(70 \times 10^6)(0.04 \times 10^3) =$   
 c.  $(0.002 \times 10^7)(600 \times 10^5)/(5 \times 10^4) =$   
 d.  $(6.2 \times 10^4)^2(82 \times 10^{-3})/(4.02 \times 10^3) =$



## GLOSSARY

- Artificial intelligence** A broad term for any technological effort to replicate the brain's functions.
- Cathode-ray tube (CRT)** A glass enclosure with a relatively flat face (screen) and a vacuum inside that will display the light generated from the bombardment of the screen by electrons.
- CGS system** The system of units employing the Centimeter, Gram, and Second as its fundamental units of measure.
- Difference engine** One of the first mechanical calculators.
- Edison effect** Establishing a flow of charge between two elements in an evacuated tube.
- Electromagnetism** The relationship between magnetic and electrical effects.
- Engineering notation** A method of notation that specifies that all powers of ten used to define a number be multiples of 3 with a mantissa greater than or equal to 1 but less than 1000.
- ENIAC** The first totally electronic computer.
- Fixed-point notation** Notation using a decimal point in a particular location to define the magnitude of a number.
- Fleming's valve** The first of the electronic devices, the diode.
- Floating-point notation** Notation that allows the magnitude of a number to define where the decimal point should be placed.
- Integrated circuit (IC)** A subminiature structure containing a vast number of electronic devices designed to perform a particular set of functions.
- Joule (J)** A unit of measurement for energy in the SI or MKS system. Equal to 0.7378 foot-pound in the English system and  $10^7$  ergs in the CGS system.
- Kelvin (K)** A unit of measurement for temperature in the SI system. Equal to  $273.15 + ^\circ\text{C}$  in the MKS and CGS systems.
- Kilogram (kg)** A unit of measure for mass in the SI and MKS systems. Equal to 1000 grams in the CGS system.
- Language** A communication link between user and computer to define the operations to be performed and the results to be displayed or printed.
- Leyden jar** One of the first charge-storage devices.
- Menu** A computer-generated list of choices for the user to determine the next operation to be performed.
- Meter (m)** A unit of measure for length in the SI and MKS systems. Equal to 1.094 yards in the English system and 100 centimeters in the CGS system.
- MKS system** The system of units employing the Meter, Kilogram, and Second as its fundamental units of measure.
- Nanotechnology** The production of integrated circuits in which the nanometer is the typical unit of measurement.
- Newton (N)** A unit of measurement for force in the SI and MKS systems. Equal to 100,000 dynes in the CGS system.
- Pound (lb)** A unit of measurement for force in the English system. Equal to 4.45 newtons in the SI or MKS system.
- Program** A sequential list of commands, instructions, and so on, to perform a specified task using a computer.
- Scientific notation** A method for describing very large and very small numbers through the use of powers of ten, which requires that the multiplier be a number between 1 and 10.
- Second (s)** A unit of measurement for time in the SI, MKS, English, and CGS systems.
- SI system** The system of units adopted by the IEEE in 1965 and the USASI in 1967 as the International System of Units (*Système International d'Unités*).
- Slug** A unit of measure for mass in the English system. Equal to 14.6 kilograms in the SI or MKS system.
- Software package** A computer program designed to perform specific analysis and design operations or generate results in a particular format.
- Static electricity** Stationary charge in a state of equilibrium.
- Transistor** The first semiconductor amplifier.
- Voltaic cell** A storage device that converts chemical to electrical energy.

*This page is intentionally left blank*

# Voltage and Current

# 2

## Objectives

- *Become aware of the basic atomic structure of conductors such as copper and aluminum and understand why they are used so extensively in the field.*
- *Understand how the terminal voltage of a battery or any dc supply is established and how it creates a flow of charge in the system.*
- *Become aware of the various sources of dc power.*
- *Understand how current is established in a circuit and how its magnitude is affected by the elements it encounters.*
- *Become familiar with the factors that affect the terminal voltage of a battery and how long a battery will remain effective.*
- *Be able to apply a voltmeter and ammeter correctly to measure the voltage and current at any point in the network.*

## 2.1 INTRODUCTION

Now that the foundation for the study of electricity/electronics has been established, the concepts of voltage and current can be investigated. The term **voltage** is encountered practically every day. We have all replaced batteries in our flashlights, answering machines, calculators, automobiles, and so on, that had specific voltage ratings. We are aware that most outlets in our homes are 120 volts ac. Although **current** may be a less familiar term, we know what happens when we place too many appliances on the same outlet—the circuit breaker opens due to the excessive current that results. It is fairly common knowledge that current is something that moves through the wires and causes sparks and possibly fire if there is a “short circuit.” Current heats up the coils of an electric heater or the burners of an electric stove; it generates light when passing through the filament of a bulb; it causes twists and kinks in the wire of an electric iron over time due to the heat generated; and so on. All in all, the terms *voltage* and *current* are part of the vocabulary of most individuals.

In this chapter, the basic impact of current and voltage and the properties of each are introduced and discussed in some detail. Hopefully, any mysteries surrounding the general characteristics of each will be eliminated, and you will gain a clear understanding of the impact of each on an electric/electronics circuit.

## 2.2 ATOMS AND THEIR STRUCTURE

A basic understanding of the fundamental concepts of current and voltage requires a degree of familiarity with the atom and its structure. The simplest of all atoms is the hydrogen atom, made up of two basic particles, the **proton** and the **electron**, in the relative positions shown in Fig. 2.1(a). The **nucleus** of the hydrogen atom is the proton, a positively charged particle.

*The orbiting electron carries a negative charge equal in magnitude to the positive charge of the proton.*



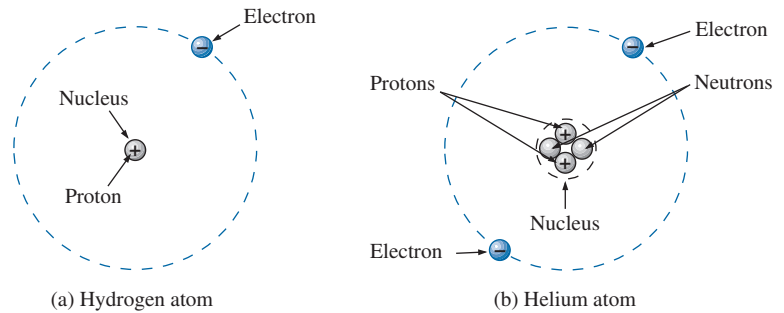

**FIG. 2.1**  
*Hydrogen and helium atoms.*

In all other elements, the nucleus also contains **neutrons**, which are slightly heavier than protons and have no *electrical charge*. The helium atom, for example, has two neutrons in addition to two electrons and two protons, as shown in Fig. 2.1(b). In general,

***the atomic structure of any stable atom has an equal number of electrons and protons.***

Different atoms have various numbers of electrons in concentric orbits called *shells* around the nucleus. The first shell, which is closest to the nucleus, can contain only two electrons. If an atom has three electrons, the extra electron must be placed in the next shell. The number of electrons in each succeeding shell is determined by  $2n^2$ , where  $n$  is the shell number. Each shell is then broken down into subshells where the number of electrons is limited to 2, 6, 10, and 14 in that order as you move away from the nucleus.

**Copper** is the most commonly used metal in the electrical/electronics industry. An examination of its atomic structure will reveal why it has such widespread application. As shown in Fig. 2.2, it has 29 electrons in orbits around the nucleus, with the 29th electron appearing all by itself in the 4th shell. Note that the number of electrons in each shell and subshell

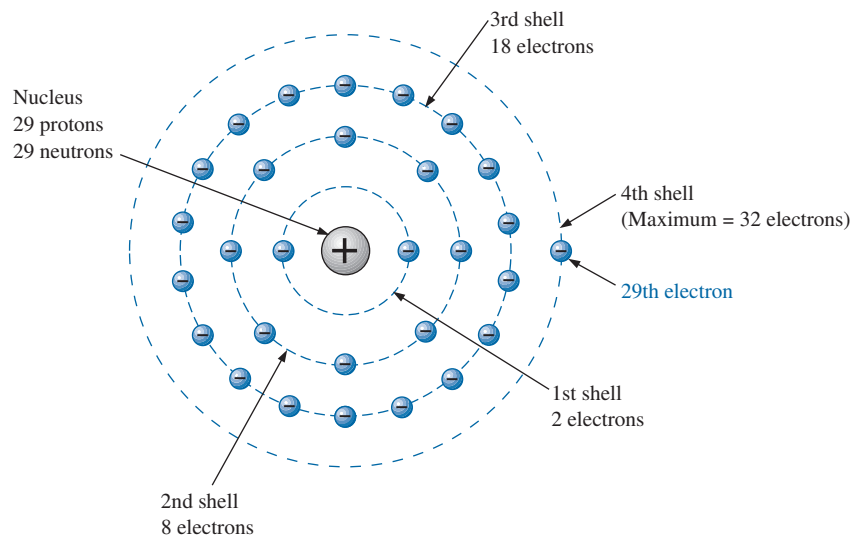

**FIG. 2.2**  
*The atomic structure of copper.*

is as defined above. There are two important things to note in Fig. 2.2. First, the 4th shell, which can have a total of  $2n^2 = 2(4)^2 = 32$  electrons, has only one electron. The outermost shell is incomplete and, in fact, is far from complete because it has only one electron. Atoms with complete shells (that is, a number of electrons equal to  $2n^2$ ) are usually quite stable. Those atoms with a small percentage of the defined number for the outermost shell are normally considered somewhat unstable and volatile. Second, the 29th electron is the farthest electron from the nucleus. Opposite charges are attracted to each other, but the farther apart they are, the less the attraction. In fact, the force of attraction between the nucleus and the 29th electron of copper can be determined by **Coulomb's law** developed by Charles Augustin Coulomb (Fig. 2.3) in the late 18th century:

$$F = k \frac{Q_1 Q_2}{r^2} \quad (\text{newtons, N}) \quad (2.1)$$

where  $F$  is in newtons (N),  $k = \text{a constant} = 9.0 \times 10^9 \text{ Nm}^2/\text{C}^2$ ,  $Q_1$  and  $Q_2$  are the charges in coulombs (a unit of measure discussed in the next section), and  $r$  is the distance between the two charges in meters.

At this point, the most important thing to note is that the distance between the charges appears as a squared term in the denominator. First, the fact that this term is in the denominator clearly reveals that as it increases, the force will decrease. However, since it is a squared term, the force will drop dramatically with distance. This relationship where a parameter of interest has a squared term in the denominator occurs frequently in this and related fields, so we will take a closer look at its impact. Defining  $k' = kQ_1Q_2$ , Eq. (2.1) will become the following:

$$F = \frac{kQ_1Q_2}{r^2} = \frac{k'}{r^2}$$

For very small distances between charges, the force of attraction or repulsion will be very high.

Consider  $r = 0.3 \text{ m}$ . The resulting force is

$$F = \frac{k'}{r^2} = \frac{k'}{(0.3)^2} \cong 11.1 k'$$

For  $r = 1 \text{ m}$ :

$$F = \frac{k'}{r^2} = \frac{k'}{(1)^2} = k'$$

For  $r = 2 \text{ m}$ :

$$F = \frac{k'}{r^2} = \frac{k'}{(2)^2} = \frac{k'}{4} = 0.25k'$$

and for  $r = 10 \text{ m}$ :

$$F = \frac{k'}{r^2} = \frac{k'}{(10)^2} = \frac{k'}{100} = 0.01k'$$

A plot of force versus distance is provided as Fig. 2.4. Clearly the squared term in the denominator has a dramatic effect on the level of attraction or repulsion between two charges. The result, therefore, is that the force of attraction between the 29th electron and the nucleus is significantly less than that between an electron in the first shell and

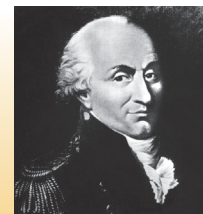

FIG. 2.3

Charles Augustin Coulomb.

INTERFOTO/Personalities/  
Alamy Stock Photo

**French** (Angoulême, Paris)  
**(1736–1806) Scientist and Inventor**  
**Military Engineer, West Indies**

Attended the engineering school at Mézières, the first such school of its kind. Formulated *Coulomb's law*, which defines the force between two electrical charges and is, in fact, one of the principal forces in atomic reactions. Performed extensive research on the friction encountered in machinery and windmills and the elasticity of metal and silk fibers.

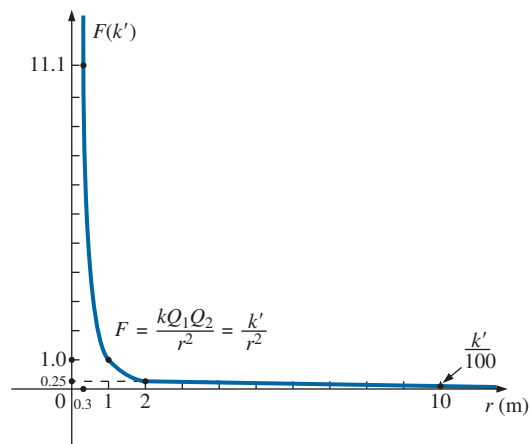

FIG. 2.4

Demonstrating the impact of a squared term in the denominator of an expression.



the nucleus. The result is that the 29th electron is loosely bound to the atomic structure and with a little bit of pressure from outside sources could be encouraged to leave the parent atom.

If this 29th electron gains sufficient energy from the surrounding medium to leave the parent atom, it is called a **free electron**. In 1 cubic in. of copper at room temperature, there are approximately  $1.4 \times 10^{24}$  free electrons. Expanded, that is 1,400,000,000,000,000,000,000,000 free electrons in a 1-in. square cube. The point is that we are dealing with enormous numbers of electrons when we talk about the number of free electrons in a copper wire—not just a few that you could leisurely count. Further, the numbers involved are clear evidence of the need to become proficient in the use of powers of ten to represent numbers and use them in mathematical calculations.

Other metals that exhibit the same properties as copper, but to a different degree, are silver, gold, and aluminum, and some rarer metals such as tungsten. Additional comments on the characteristics of conductors are in the following sections.

## 2.3 VOLTAGE

If we separate the 29th electron in Fig. 2.2 from the rest of the atomic structure of copper by a dashed line as shown in Fig. 2.5(a), we create regions that have a net positive and negative charge as shown in Fig. 2.5(b) and (c). For the region inside the dashed boundary, the number of protons in the nucleus exceeds the number of orbiting electrons by 1, so the net charge is positive as shown in both figures. This positive region created by separating the free electron from the basic atomic structure is called a **positive ion**. If the free electron then leaves the vicinity of the parent atom as shown in Fig. 2.5(d), regions of positive and negative charge have been established.

This separation of charge to establish regions of positive and negative charge is the action that occurs in every battery. Through chemical action, a heavy concentration of positive charge (positive ions) is established at the positive terminal, with an equally heavy concentration of negative charge (electrons) at the negative terminal.

In general,

**every source of voltage is established by simply creating a separation of positive and negative charges.**

It is that simple: If you want to create a voltage level of any magnitude, simply establish regions of positive and negative charge. The more the required voltage, the greater is the quantity of positive and negative charge.

In Fig. 2.6(a), for example, a region of positive charge has been established by a packaged number of positive ions, and a region of negative charge by a similar number of electrons, separated by a distance  $r$ . Since it would be inconsequential to talk about the voltage established by the separation of a single electron, a package of electrons called a **coulomb (C)** of charge was defined as follows:

**One coulomb of charge is the total charge associated with  $6.242 \times 10^{18}$  electrons.**

Conversely, the negative charge associated with a single electron is

$$Q_e = \frac{1}{6.242 \times 10^{18}} \text{C} = 0.1602 \times 10^{-18} \text{C}$$

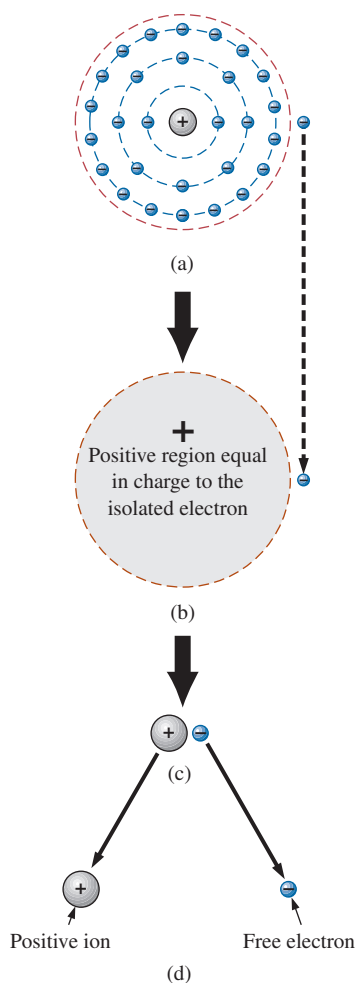
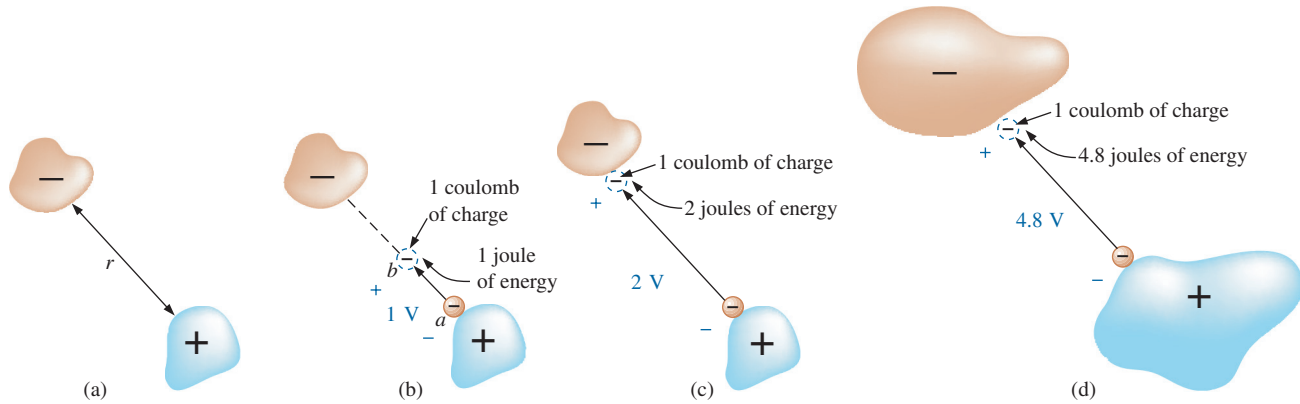

**FIG. 2.5**  
Defining the positive ion.



so that

$$Q_e = 1.602 \times 10^{-19} \text{ C} \quad (2.2)$$



**FIG. 2.6**  
Defining the voltage between two points.

In Fig. 2.6(b), if we take a coulomb of negative charge near the surface of the positive charge and move it toward the negative charge, we must expend energy to overcome the repulsive forces of the larger negative charge and the attractive forces of the positive charge. In the process of moving the charge from point *a* to point *b* in Fig. 2.6(b),

***if a total of 1 joule (J) of energy is used to move the negative charge of 1 coulomb (C), there is a difference of 1 volt (V) between the two points.***

The defining equation is

$$V = \frac{W}{Q} \quad \begin{array}{l} V = \text{volts (V)} \\ W = \text{joules (J)} \\ Q = \text{coulombs (C)} \end{array} \quad (2.3)$$

Take particular note that the charge is measured in coulombs, the energy in joules, and the voltage in volts. The unit of measurement, **volt**, was chosen to honor the efforts of Alessandro Volta, who first demonstrated that a voltage could be established through chemical action (Fig. 2.7).

If the charge is now moved all the way to the surface of the larger negative charge as shown in Fig. 2.6(c), using 2 J of energy for the whole trip, there are 2 V between the two charged bodies. If the package of positive and negative charge is larger, as shown in Fig. 2.6(d), more energy will have to be expended to overcome the larger repulsive forces of the large negative charge and attractive forces of the large positive charge. As shown in Fig. 2.6(d), 4.8 J of energy were expended, resulting in a voltage of 4.8 V between the two points. We can therefore conclude that it would take 12 J of energy to move 1 C of negative charge from the positive terminal to the negative terminal of a 12 V car battery.

Through algebraic manipulations, we can define an equation to determine the energy required to move charge through a difference in voltage:

$$W = QV \quad (\text{joules, J}) \quad (2.4)$$

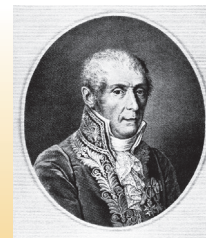

**FIG. 2.7**  
**Count Alessandro Volta.**  
Bilwisedition Ltd. & Co.  
KG/Alamy Stock Photo

**Italian** (Como, Pavia)  
**(1745–1827) Physicist**  
**Professor of Physics,**  
Pavia, Italy

Began electrical experiments at the age of 18 working with other European investigators. Major contribution was the development of an electrical energy source from chemical action in 1800. For the first time, electrical energy was available on a continuous basis and could be used for practical purposes. Developed the first *condenser*, known today as the *capacitor*. Was invited to Paris to demonstrate the *voltaic cell* to Napoleon. The International Electrical Congress meeting in Paris in 1881 honored his efforts by choosing the *volt* as the unit of measure for electromotive force.



Finally, if we want to know how much charge was involved, we use

$$Q = \frac{W}{V} \quad (\text{coulombs, C}) \quad (2.5)$$

**EXAMPLE 2.1** Find the voltage between two points if 60 J of energy are required to move a charge of 20 C between the two points.

**Solution:** Eq. (2.3):  $V = \frac{W}{Q} = \frac{60 \text{ J}}{20 \text{ C}} = 3 \text{ V}$

**EXAMPLE 2.2** Determine the energy expended moving a charge of 50  $\mu\text{C}$  between two points if the voltage between the points is 6 V.

**Solution:** Eq. (2.4):

$$W = QV = (50 \times 10^{-6} \text{ C})(6 \text{ V}) = 300 \times 10^{-6} \text{ J} = 300 \mu\text{J}$$

There are a variety of ways to separate charge to establish the desired voltage. The most common is the chemical action used in car batteries, flashlight batteries, and, in fact, all portable batteries. Other sources use mechanical methods such as car generators and steam power plants or alternative sources such as solar cells and windmills. In total, however, the sole purpose of the system is to create a separation of charge. In the future, therefore, when you see a positive and a negative terminal on any type of battery, you can think of it as a point where a large concentration of charge has gathered to create a voltage between the two points. More important is to recognize that a voltage exists between two points—for a battery between the positive and negative terminals. Hooking up just the positive or the negative terminal of a battery and not the other would be meaningless.

**Both terminals must be connected to define the applied voltage.**

As we moved the 1 C of charge in Fig. 2.6(b), the energy expended would depend on where we were in the crossing. The *position* of the charge is therefore a factor in determining the voltage level at each point in the crossing. Since the **potential energy** associated with a body is defined by its position, the term *potential* is often applied to define voltage levels. For example, the difference in potential is 4 V between the two points, or the **potential difference** between a point and ground is 12 V, and so on.

### The electron volt

A unit of energy sometimes applied in a number of physics oriented investigations is the **electron volt**.

It is the level of energy required to move an electron through a potential difference of 1 volt.

Applying the basic energy equation,

$$\begin{aligned} W &= QV \\ &= (1.602 \times 10^{-19} \text{ C})(1 \text{ volt}) \\ W &= 1.602 \times 10^{-19} \text{ J} \end{aligned}$$



and

$$1 \text{ eV} = 1.602 \times 10^{-19} \text{ J} \quad (2.6)$$

Conversely,

$$1 \text{ J} = \frac{1}{1.602 \times 10^{-19}} \text{ eV}$$

and

$$1 \text{ J} = 2.24 \times 10^{18} \text{ eV} \quad (2.7)$$

## 2.4 CURRENT

The question, “Which came first—the chicken or the egg?” can be applied here also because the layperson has a tendency to use the terms *current* and *voltage* interchangeably as if both were sources of energy. It is time to set things straight:

***The applied voltage is the starting mechanism—the current is a reaction to the applied voltage.***

In Fig. 2.8(a), a copper wire sits isolated on a laboratory bench. If we cut the wire with an imaginary perpendicular plane, producing the circular cross section shown in Fig. 2.8(b), we would be amazed to find that there are free electrons crossing the surface in both directions. Those free electrons generated at room temperature are in constant motion in random directions. However, at any instant of time, the number of electrons crossing the imaginary plane in one direction is exactly equal to that crossing in the opposite direction, so the *net flow in any one direction is zero*. Even though the wire seems dead to the world sitting by itself on the bench, internally, it is quite active. The same would be true for any other good conductor.

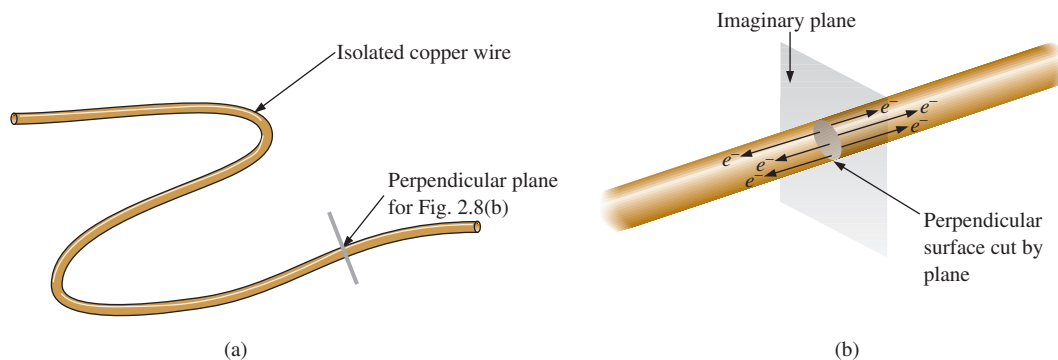

**FIG. 2.8**

*There is motion of free carriers in an isolated piece of copper wire, but the flow of charge fails to have a particular direction.*

Now, to make this electron flow do work for us, we need to give it a direction and be able to control its magnitude. This is accomplished by simply applying a voltage across the wire to force the electrons to move toward the positive terminal of the battery, as shown in Fig. 2.9. The instant the wire is placed across the terminals, the free electrons in the wire drift toward the positive terminal. The positive ions in the copper wire simply oscillate in a mean fixed position. As the electrons pass

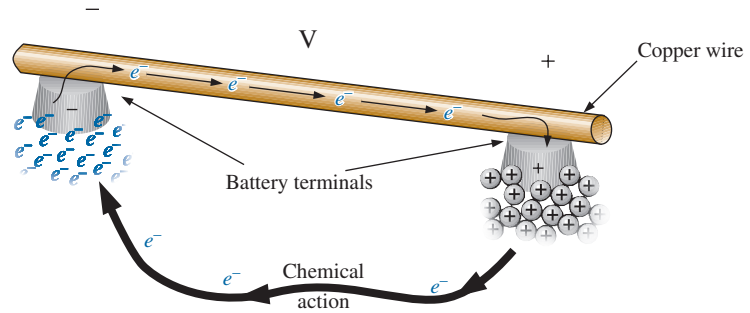

FIG. 2.9

*Motion of negatively charged electrons in a copper wire when placed across battery terminals with a difference in potential of volts (V).*

through the wire, the negative terminal of the battery acts as a supply of additional electrons to keep the process moving. The electrons arriving at the positive terminal are absorbed, and through the chemical action of the battery, additional electrons are deposited at the negative terminal to make up for those that left.

To take the process a step further, consider the configuration in Fig. 2.10, where a copper wire has been used to connect a light bulb to a battery to create the simplest of electric circuits. The instant the final connection is made, the free electrons of negative charge drift toward the positive terminal, while the positive ions left behind in the copper wire simply oscillate in a mean fixed position. The flow of charge (the electrons) through the bulb heats up the filament of the bulb through friction to the point that it glows red-hot and emits the desired light.

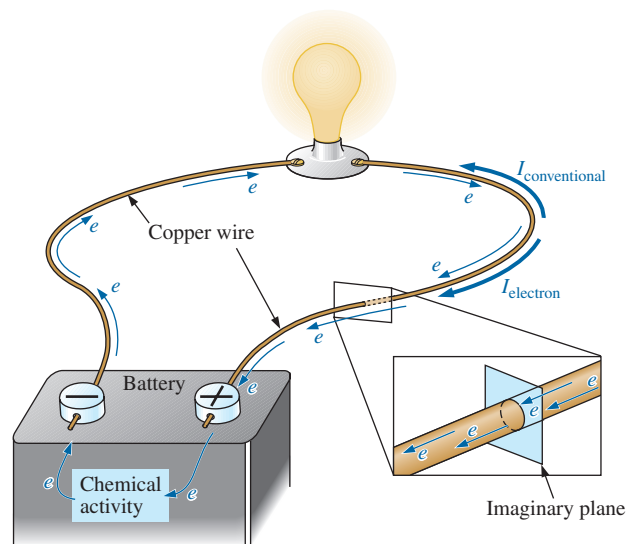

FIG. 2.10

*Basic electric circuit.*

In total, therefore, the applied voltage has established a flow of electrons in a particular direction. In fact, by definition,

***if  $6.242 \times 10^{18}$  electrons (1 coulomb) pass through the imaginary plane in Fig. 2.10 in 1 second, the flow of charge, or current, is said to be 1 ampere (A).***



The unit of current measurement, **ampere**, was chosen to honor the efforts of André Ampère in the study of electricity in motion (Fig. 2.11).

Using the coulomb as the unit of charge, we can determine the current in amperes from the following equation:

$$I = \frac{Q}{t} \quad \begin{array}{l} I = \text{amperes (A)} \\ Q = \text{coulombs (C)} \\ t = \text{time (s)} \end{array} \quad (2.8)$$

The capital letter  $I$  was chosen from the French word for current, *intensité*. The SI abbreviation for each quantity in Eq. (2.8) is provided to the right of the equation. The equation clearly reveals that for equal time intervals, the more charge that flows through the wire, the larger is the resulting current.

Through algebraic manipulations, the other two quantities can be determined as follows:

$$Q = It \quad (\text{coulombs, C}) \quad (2.9)$$

and

$$t = \frac{Q}{I} \quad (\text{seconds, s}) \quad (2.10)$$

**EXAMPLE 2.3** The charge flowing through the imaginary surface in Fig. 2.10 is 0.16 C every 64 ms. Determine the current in amperes.

**Solution:** Eq. (2.8):

$$I = \frac{Q}{t} = \frac{0.16 \text{ C}}{64 \times 10^{-3} \text{ s}} = \frac{160 \times 10^{-3} \text{ C}}{64 \times 10^{-3} \text{ s}} = 2.50 \text{ A}$$

**EXAMPLE 2.4** Determine how long it will take  $4 \times 10^{16}$  electrons to pass through the imaginary surface in Fig. 2.10 if the current is 5 mA.

**Solution:** Determine the charge in coulombs:

$$4 \times 10^{16} \text{ electrons} \left( \frac{1 \text{ C}}{6.242 \times 10^{18} \text{ electrons}} \right) = 0.641 \times 10^{-2} \text{ C} \\ = 6.41 \text{ mC}$$

$$\text{Eq. (2.10): } t = \frac{Q}{I} = \frac{6.41 \times 10^{-3} \text{ C}}{5 \times 10^{-3} \text{ A}} = 1.28 \text{ s}$$

In summary, therefore,

***the applied voltage (or potential difference) in an electrical/electronics system is the “pressure” to set the system in motion, and the current is the reaction to that pressure.***

A mechanical analogy often used to explain this is the simple garden hose. In the absence of any pressure, the water sits quietly in the hose with no general direction, just as electrons do not have a net direction in the absence of an applied voltage. However, release the spigot, and the applied pressure forces the water to flow through the hose. Similarly, apply a voltage to the circuit, and a flow of charge or current results.

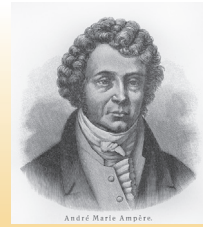

**FIG. 2.11**

*André Marie Ampère.*  
Nickolae/Fotolia

**French** (Lyon, Paris)  
(1775–1836)

**Mathematician and Physicist**  
**Professor of Mathematics,**  
École Polytechnique, Paris

On September 18, 1820, introduced a new field of study, electrodynamics, devoted to the effect of electricity in motion, including the interaction between currents in adjoining conductors and the interplay of the surrounding magnetic fields. Constructed the first *solenoid* and demonstrated how it could behave like a magnet (the first *electromagnet*). Suggested the name *galvanometer* for an instrument designed to measure current levels.



A second glance at Fig. 2.10 reveals that two directions of charge flow have been indicated. One is called **conventional flow**, and the other is called **electron flow**. This text discusses only conventional flow for a variety of reasons; namely, it is the most widely used at educational institutions and in industry, it defines the direction of the arrow in the design of all electronic device symbols, and it is the popular choice for all major computer software packages. The flow controversy is a result of an assumption made at the time electricity was discovered that the positive charge was the moving particle in metallic conductors. Be assured that the choice of conventional flow will not create great difficulty and confusion in the chapters to follow. Once the direction of  $I$  is established, the issue is dropped and the analysis can continue without confusion.

## Safety Considerations

It is important to realize that even small levels of current through the human body can cause serious, dangerous side effects. Experimental results reveal that the human body begins to react to currents of only a few milliamperes. Although most individuals can withstand currents up to perhaps 10 mA for very short periods of time without serious side effects, any current over 10 mA should be considered dangerous. In fact, currents of 50 mA can cause severe shock, and currents of over 100 mA can be fatal. In most cases, the skin resistance of the body when dry is sufficiently high to limit the current through the body to relatively safe levels for voltage levels typically found in the home. However, if the skin is wet due to perspiration, bathing, and so on, or if the skin barrier is broken due to an injury, the skin resistance drops dramatically, and current levels could rise to dangerous levels for the same voltage shock. In general, therefore, simply remember that *water and electricity don't mix*. Granted, there are safety devices in the home today [such as the ground fault circuit interrupt (GFCI) receptacle and breakers, discussed in Chapter 4] that are designed specifically for use in wet areas such as the bathroom and kitchen, but accidents happen. Treat electricity with respect—not fear.

## 2.5 VOLTAGE SOURCES

The term **dc**, used throughout this text, is an abbreviation for **direct current**, which encompasses all systems where there is a unidirectional (one direction) flow of charge. This section reviews dc voltage supplies that apply a fixed voltage to electrical/electronics systems.

The graphic symbol for all dc voltage sources is shown in Fig. 2.12. Note that the relative length of the bars at each end define the polarity of the supply. The long bar represents the positive side; the short bar, the negative. Note also the use of the letter  $E$  to denote *voltage source*. It comes from the fact that

***an electromotive force (emf) is a force that establishes the flow of charge (or current) in a system due to the application of a difference in potential.***

In general, dc voltage sources can be divided into three basic types: (1) batteries (chemical action or solar energy), (2) generators (electromechanical), and (3) power supplies (rectification—a conversion process to be described in your electronics courses).

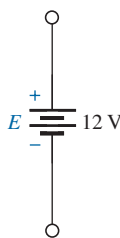

**FIG. 2.12**

Standard symbol for a dc voltage source.

## Batteries

**General Information** For the layperson, the battery is the most common of the dc sources. By definition, a battery (derived from the expression “battery of cells”) consists of a combination of two or more similar **cells**, a cell being the fundamental source of electrical energy developed through the conversion of chemical or solar energy. All cells can be divided into the **primary** or **secondary** types. The secondary is rechargeable, whereas the primary is not. That is, the chemical reaction of the secondary cell can be reversed to restore its capacity. The two most common rechargeable batteries are the lead-acid unit (used primarily in automobiles) and the nickel–metal hydride (NiMH) battery (used in calculators, tools, photoflash units, shavers, and so on). The obvious advantages of rechargeable units are the savings in time and money of not continually replacing discharged primary cells.

All the cells discussed in this chapter (except the **solar cell**, which absorbs energy from incident light in the form of photons) establish a potential difference at the expense of chemical energy. In addition, each has a positive and a negative *electrode* and an **electrolyte** to complete the circuit between electrodes within the battery. The electrolyte is the contact element and the source of ions for conduction between the terminals.

**Primary Cells (Nonrechargeable)** The popular alkaline primary battery uses a powdered zinc anode (+); a potassium (alkali metal) hydroxide electrolyte; and a manganese dioxide/carbon cathode (–) as shown in Fig. 2.13(a). In Fig. 2.13(b), note that for the cylindrical types (AAA, AA, C, and D), the voltage is the same for each, but the ampere-hour (Ah) rating increases significantly with size. The ampere-hour rating is an indication of the level of current that the battery can provide for a specified period of time (to be discussed in detail in Section 2.6). In particular, note that for the large, lantern-type battery, the voltage is only 4 times that of the AAA battery, but the ampere-hour rating of 52 Ah is almost 42 times that of the AAA battery.



**FIG. 2.13**

Alkaline primary cells: (a) cutaway of cylindrical cell; (b) various types of primary cells.

[(b) photo by Robert Boylestad]

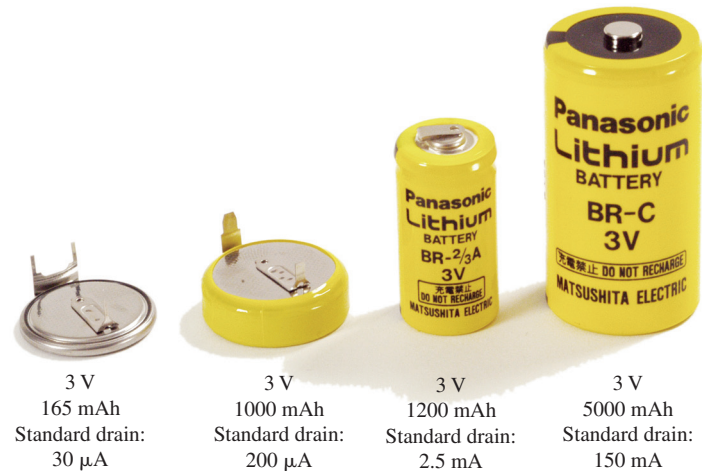

**FIG. 2.14**  
*Lithium primary batteries.*

Another type of popular primary cell is the lithium battery, shown in Fig. 2.14. Again, note that the voltage is the same for each, but the size increases substantially with the ampere-hour rating and the rated drain current. It is particularly useful when low temperature is encountered.

In general, therefore,

***for batteries of the same type, the size is dictated primarily by the standard drain current or ampere-hour rating, not by the terminal voltage rating.***

### Secondary Cells (Rechargeable)

***Lead-Acid:*** The 12 V of Fig. 2.15, typically used in automobiles, has an electrolyte of sulfuric acid and electrodes of spongy lead (Pb) and lead peroxide ( $\text{PbO}_2$ ). When a load is applied to the battery terminals, there is a transfer of electrons from the spongy lead electrode to the lead peroxide electrode through the load. This transfer of electrons

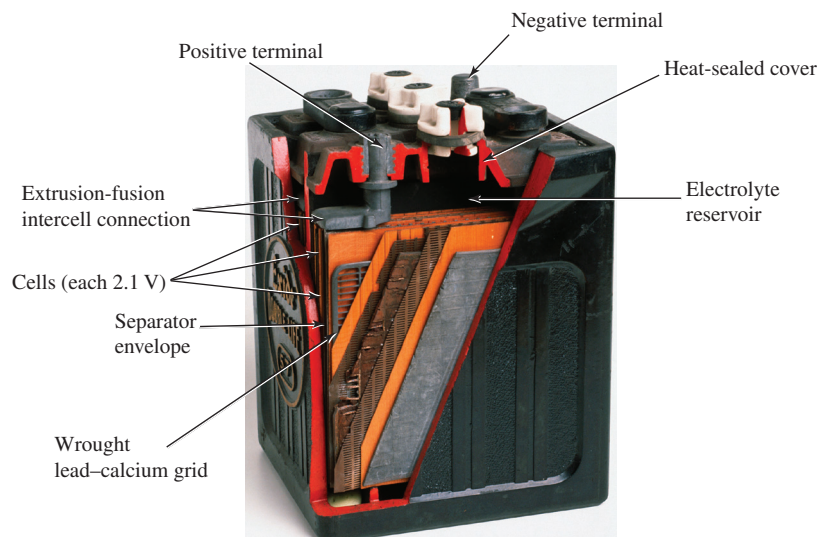

**FIG. 2.15**  
*Maintenance-free 12 V (actually 12.6 V) lead-acid battery.*  
(Clive Streeeter/DK Images)

will continue until the battery is completely discharged. The discharge time is determined by how diluted the acid has become and how heavy the coating of lead sulfate is on each plate. The state of discharge of a lead storage cell can be determined by measuring the **specific gravity** of the electrolyte with a hydrometer. The specific gravity of a substance is defined to be the ratio of the weight of a given volume of the substance to the weight of an equal volume of water at 4°C. For fully charged batteries, the specific gravity should be somewhere between 1.28 and 1.30. When the specific gravity drops to about 1.1, the battery should be recharged.

Since the lead storage cell is a secondary cell, it can be recharged at any point during the discharge phase simply by applying an external **dc current source** across the cell that passes current through the cell in a direction opposite to that in which the cell supplied current to the load. This removes the lead sulfate from the plates and restores the concentration of sulfuric acid.

The output of a lead storage cell over most of the discharge phase is about 2.1 V. In the commercial lead storage batteries used in automobiles, 12.6 V can be produced by six cells in series, as shown in Fig. 2.15. In general, lead-acid storage batteries are used in situations where a high current is required for relatively short periods of time. At one time, all lead-acid batteries were vented. Gases created during the discharge cycle could escape, and the vent plugs provided access to replace the water or electrolyte and to check the acid level with a hydrometer. The use of a grid made from a wrought lead–calcium alloy strip, rather than the lead–antimony cast grid commonly used, has resulted in maintenance-free batteries, shown in Fig. 2.15. The lead–antimony structure was susceptible to corrosion, overcharge, gassing, water usage, and self-discharge. Improved design with the lead–calcium grid has either eliminated or substantially reduced most of these problems.

It would seem that with so many advances in technology, the size and weight of the lead–acid battery would have decreased significantly in recent years, but even today it is used more than any other battery in automobiles and all forms of machinery. However, things are beginning to change with interest in nickel–metal hydride and lithium-ion batteries, which both pack more power per unit size than the lead–acid variety. Both will be described in the sections to follow.

**Nickel–Metal Hydride (NiMH):** The nickel–metal hydride rechargeable battery has been receiving enormous interest and development in recent years. The Toyota Prius and two other hybrids would use NiMH batteries rather than the lead–acid variety. For applications such as flashlights, shavers, portable televisions, power drills, and so on, rechargeable batteries such as the nickel–metal hydride (NiMH) batteries shown in Fig. 2.16 are often the secondary batteries of choice. These batteries are so well made that they can survive over 1000 charge/discharge cycles over a period of time and can last for years.

It is important to recognize that if an appliance calls for a rechargeable battery such as a NiMH battery, a primary cell should not be used. The appliance may have an internal charging network that would be dysfunctional with a primary cell. In addition, note that NiMH batteries are about 1.2 V per cell, whereas the common primary cells are typically 1.5 V per cell.

There is some ambiguity about how often a secondary cell should be recharged. Generally, the battery can be used until there is some indication that the energy level is low, such as a dimming light from a flashlight, less



**FIG. 2.17**

*iPhone.*

(a) STANCA SANDA/Alamy Stock Photo  
(b) Brent Lewin/Bloomberg/Getty Images

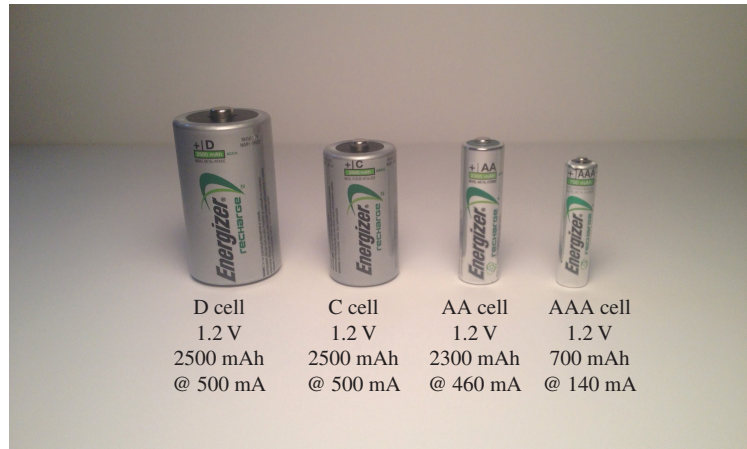

**FIG. 2.16**

*Nickel–metal hydride (NiMH) rechargeable batteries.*  
(photo by Robert Boylestad)

power from a drill, or a signal from low-battery indicator. Keep in mind that secondary cells do have some “memory.” If they are recharged continuously after being used for a short period of time, they may begin to believe they are short-term units and actually fail to hold the charge for the rated period of time. In any event, always try to avoid a “hard” discharge, which results when every bit of energy is drained from a cell. Too many hard-discharge cycles will reduce the cycle life of the battery. Finally, be aware that the charging mechanism for nickel–cadmium cells is quite different from that for lead–acid batteries. The nickel–cadmium battery is charged by a constant–current source, with the terminal voltage staying fairly steady through the entire charging cycle. The lead–acid battery is charged by a constant voltage source, permitting the current to vary as determined by the state of the battery. The capacity of the NiMH battery increases almost linearly throughout most of the charging cycle. Nickel–cadmium batteries become relatively warm when charging. The lower the capacity level of the battery when charging, the higher is the temperature of the cell. As the battery approaches rated capacity, the temperature of the cell approaches room temperature.

**Lithium-ion (Li-ion):** The battery receiving the most research and development in recent years is the lithium-ion battery. It carries more energy in a smaller space than either the lead–acid or NiMH rechargeable batteries. Its range of applications includes computers, a host of consumer products, power tools, and recently the sleek Tesla roadster with its battery pack composed of more than 6800 3.7 V Li-ion cells the size of a typical AA battery. It can travel some 265 miles but the battery pack costs between \$10,000 and \$15,000. Another problem is shelf life. Once manufactured, these batteries begin to slowly die even though they may go through normal charge/discharge cycles, which makes them similar to a normal primary cell, so lifetime is a major concern.

The very popular iPhone 4S appearing in Fig. 2.17 has a 3.7 V, 5.45 Wh lithium-ion polymer battery as its power source. Note that it takes about 40% by volume of the internal structure and contributes a great deal to its weight.

Industry is aware of the numerous positive characteristics of this power source and is pouring research money in at a very high rate. Recent

use of nanotechnology and microstructures along with improved design has alleviated many of the concerns regarding safety and longevity.

## Solar Cell

The use of solar cells as part of the effort to generate “clean” energy has grown exponentially in the last few years. At one time the cost and the low conversion efficiencies were the main stumbling blocks to widespread use of the solar cell. However, the company Nanosolar has significantly reduced the cost of solar panels by using a printing process that uses a great deal less of the expensive silicon material in the manufacturing process. Whereas the cost of generating solar electricity is about 4 to 10¢/kWh, compared to an average of 22¢/kWh using a local coal/oil utility, this new printing process has had a significant impact on reducing the cost level. Another factor that will reduce costs is the improving level of efficiency being obtained by manufacturers. At one time the accepted efficiency level of conversion was between 10% and 14%. Recently, however, the company Semprius, Inc., set a new record for commercially available solar panels with a 35.5% efficiency level—almost twice the typical commercial level. The Fraunhofer Institute for Solar Energy Systems in Germany reached a laboratory level of 44.7% conversion efficiency. The two factors that affect the cost the most are the cost of the materials and the efficiency level. Silicon is the most frequently used material but it is expensive. Recent trends have been to find improved materials and to try innovative maneuvers like stacking the cells or imbedding lenses to focus the incident light. In general, it appears that there is a strong thrust to make solar cells a very important option for generating clean energy in the near future. Given that the maximum available wattage on an average bright, sunlit day is 100 mW/cm<sup>2</sup>, the efficiency is an important element in any future plans for the expansion of solar power. At 10% to 14% efficiency the maximum available power from a 1-m<sup>2</sup> panel (approximately 3' × 3') would be 100 to 140 W. However, if the efficiency could be raised to 30%, the return could exceed 300 W per panel. When we consider the wide range of appliances that can be run on 300 W or less, this is a significant improvement.

Even though the efficiency may not be as high as desired, the important thing to remember when it comes to solar energy is that there is no cost associated with providing the energy in the first place. It is ready to be used and, hopefully, will never end. In cold climates with snow cover and long cloudy days, one might wonder about the feasibility or logic in installing solar panels. However, take a look at the fishing/hunting lodge in Fig. 2.18(a) located in northern Maine with twelve 265 W solar panels that provide a total of 3.18 kW under optimum conditions. Consider how many appliances, required in a camp of this kind, can operate with a power source of this magnitude. Keep in mind that the bank of 16 batteries will store unused energy on the sunny days for times when there is cloud cover or the panels are covered with snow. The system includes a solar charger and a 6 kW inverter to convert the dc to ac for use with appliances requiring 120V ac. During a recent visit, the owners revealed that the system works so well that they only turn on the generator about once a month for 3–5 hours, which usually occurs when a few rainy days coincide with a large group that uses the lodge late into the evening. They figure that they save about \$3500 a year on diesel and maintenance costs. Most importantly the solar system permits the use of the kitchen, laundry,



(a)

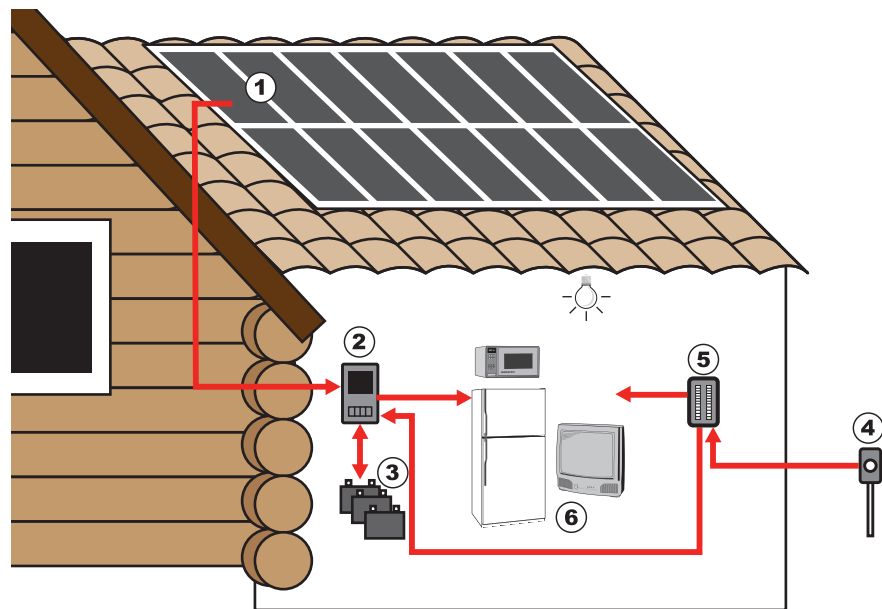

(b)

**FIG. 2.18**

*Red River Camps in Portage, Maine: (a) twelve 265 W panels on roof;*

*(b) system operations.*

[*(a) Courtesy of Red River Camps*]

and lights later in the evening, whereas with the generator as their sole source of power the supply of electricity normally ended at 10 P.M.

The basic system operates as shown in Fig. 2.18(b). The solar panels (1) convert sunlight into dc electric power. An inverter (2) converts the dc power into the standard ac power for use in the home (6). The batteries (3) can store energy from the sun for use if there is insufficient sunlight or a power failure. At night or on dark days when the demand exceeds the solar panel and battery supply, the generators (4) can provide power to the appliances (6) through a special hookup in the electrical panel (5).

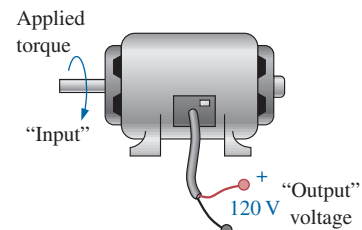

**FIG. 2.19**  
*EarthRoamer XV-LT.*  
(Virrage Images/Shutterstock)

There is no question that the use of solar panels is growing by leaps and bounds in recent years as manufacturers provide panels that meet the physical requirements of a wide range of applications. Consider the RV vehicle pictured in Fig. 2.19 designed to permit travel to all points of the globe. It has three panels of 240 W each to provide a total of 720 W of power that can be stored in a battery system with a 510 Ah capacity. The panels are obviously of a durability and strength to permit traveling in some of the harshest conditions.

## Generators

The **dc generator** is quite different from the battery, both in construction (Fig. 2.20) and in mode of operation. When the shaft of the generator is rotating at the nameplate speed due to the applied torque of some external source of mechanical power, a voltage of rated value appears across the external terminals. The terminal voltage and power-handling capabilities of the dc generator are typically higher than those of most batteries, and its lifetime is determined only by its construction. Commercially used dc generators typically have an output voltage of 120 V or 240 V. For the purposes of this text, the same symbols are used for a battery and a generator.



**FIG. 2.20**  
*dc generator.*

## Power Supplies

The dc supply encountered most frequently in the laboratory uses the **rectification** and *filtering* processes as its means toward obtaining a steady dc voltage. Both processes will be covered in detail in your basic electronics courses. In total, a time-varying voltage (such as ac voltage available from a home outlet) is converted to one of a fixed magnitude. A dc laboratory supply of this type is shown in Fig. 2.21.

Most dc laboratory supplies have a regulated, adjustable voltage output with three available terminals, as indicated horizontally at the bottom of Fig 2.21 and vertically in Fig 2.22(a). The symbol for ground or zero potential (the reference) is also shown in Fig. 2.22(a).



**FIG. 2.21**  
*A 0 V to 60 V, 0 to 1.5 A digital display dc power supply.*  
(Courtesy of B+K Precision.)

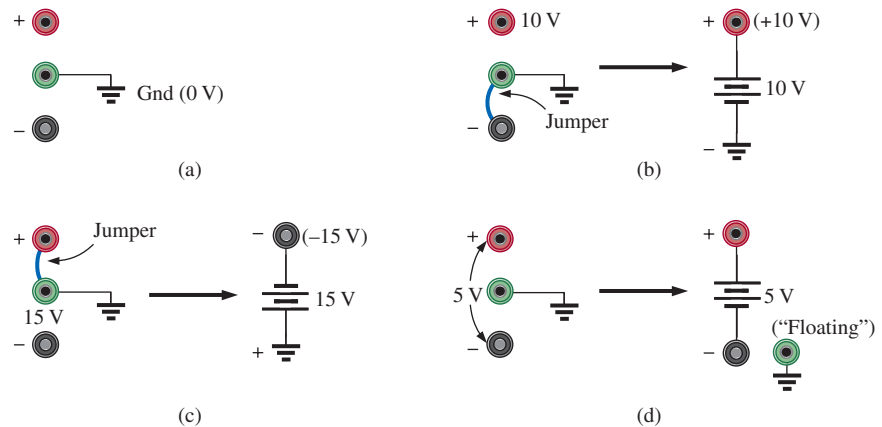

**FIG. 2.22**

*dc laboratory supply: (a) available terminals; (b) positive voltage with respect to (w.r.t.) ground; (c) negative voltage w.r.t. ground; (d) floating supply.*

If 10 V above ground potential are required, the connections are made as shown in Fig. 2.22(b). If 15 V below ground potential are required, the connections are made as shown in Fig. 2.22(c). If connections are as shown in Fig. 2.22(d), we say we have a “floating” voltage of 5 V since the reference level is not included. Seldom is the configuration in Fig. 2.22(d) used since it fails to protect the operator by providing a direct low-resistance path to ground and to establish a common ground for the system. In any case, *the positive and negative terminals must be part of any circuit configuration.*

## Fuel Cells

One of the most exciting developments in recent years has been the steadily rising interest in **fuel cells** as an alternative energy source. Fuel cells are now being used in small stationary power plants, transportation (buses), and a wide variety of applications where portability is a major factor, such as the space shuttle. A great deal of money is now being spent in an effort to design affordable fuel-cell vehicles.

Fuel cells have the distinct advantage of operating at efficiencies of 70% to 80% rather than the typical 20% to 25% efficiency of current internal combustion engine of today’s automobiles. They also have few moving parts, produce little or no pollution, generate very little noise, and use fuels such as hydrogen and oxygen that are readily available. Fuel cells are considered primary cells (of the continuous-feed variety) because they cannot be recharged. They hold their characteristics as long as the fuel (hydrogen) and oxygen are supplied to the cell. The only by-products of the conversion process are small amounts of heat (which is often used elsewhere in the system design), water (which may also be reused), and negligible levels of some oxides, depending on the components of the process. Overall, fuel cells are environmentally friendly.

The operation of the fuel cell is essentially opposite to that of the chemical process of **electrolysis**. Electrolysis is the process whereby electric current is passed through an electrolyte to break it down into its fundamental components. An electrolyte is any solution that will permit conduction through the movement of ions between adjoining electrodes. For instance, passing current through water results in a hydrogen gas by the cathode (negative terminal) and oxygen gas at the anode (positive

terminal). In 1839, Sir William Grove believed this process could be reversed and demonstrated that the proper application of the hydrogen gas and oxygen results in a current through an applied load connected to the electrodes of the system. The first commercial unit was used in a tractor in 1959, followed by an energy pack in the 1965 Gemini Space program. In 1996, the first small power plant was designed, and today it is an important component of the shuttle program.

The basic components of a fuel cell are depicted in Fig. 2.23(a) with details of the construction in Fig. 2.23(b). Hydrogen gas (the fuel) is supplied to the system at a rate proportional to the current required by the load. At the opposite end of the cell, oxygen is supplied as needed. The net result is a flow of electrons through the load and a discharge of water with a release of some heat developed in the process. The amount of heat is minimal, although it can also be used as a component in the design to improve the efficiency of the cell. The water (very clean) can simply be discharged or used for other applications such as cooling in the overall application. If the source of hydrogen or oxygen is removed, the system breaks down. The flow diagram of the system is relatively simple, as shown in Fig. 2.23(a). In an actual cell, shown in Fig. 2.23(b), the hydrogen gas is applied to a porous electrode called the *anode* that is coated with a platinum catalyst. The catalyst on the anode serves to speed up the process of breaking down the hydrogen atom into positive hydrogen ions and free electrons. The electrolyte between the electrodes is a solution or membrane that permits the passage of positive hydrogen ions but not electrons. Facing this wall, the electrons choose to pass through the load and light up the bulb, while the positive hydrogen ions migrate toward the cathode. At the porous cathode (also coated with the catalyst), the incoming oxygen atoms combine with the arriving hydrogen ions and the electrons from the circuit to create water ( $H_2O$ ) and heat. The circuit is, therefore, complete. The electrons are generated and then absorbed. If the hydrogen supply is cut off, the source of electrons is shut down, and the system is no longer an operating fuel cell.

In some fuel cells, either a liquid or molten electrolyte membrane is used. Depending on which the system uses, the chemical reactions will change slightly but not dramatically from that described above.

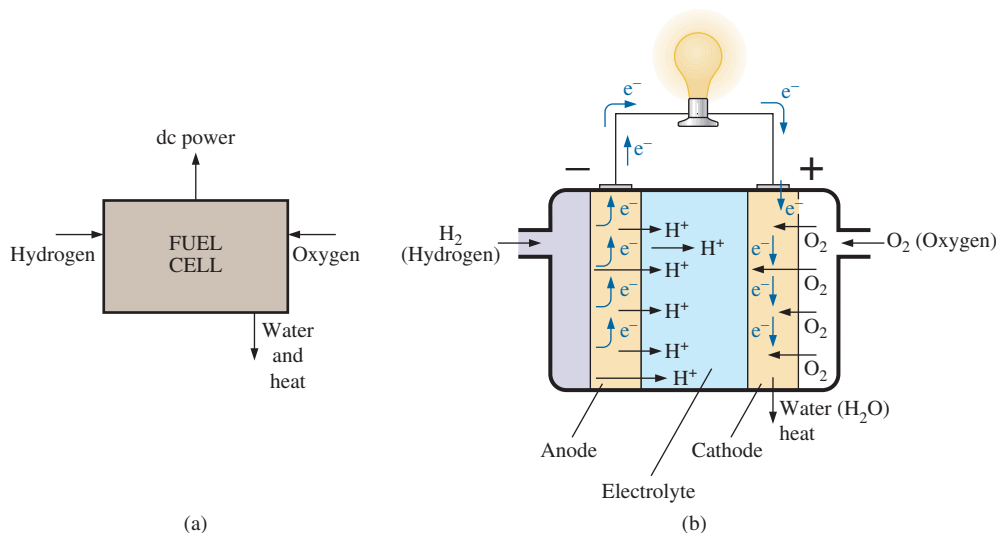

**FIG. 2.23**

*Fuel cell (a) functional block diagram; (b) basic construction.*



The phosphoric acid fuel cell is a popular cell using a liquid electrolyte, while the PEM uses a polymer electrolyte membrane. The liquid or molten type is typically used in stationary power plants, while the membrane type is favored for vehicular use.

The output from a single fuel cell is a low-voltage, high-current dc output. Stacking the cells in series or parallel increases the output voltage or current level.

For a number of years buses, trucks, motorcycles, forklifts, and many other vehicles have been running on fuel-cell technology. However, it was not until the summer of 2008 that Honda offered the FCX Clarity automobile, the first to be available for consumer use. The basic components of the vehicle are pointed out in Fig. 2.24. Basically, it is an electric car because there is no combustion and the source of power is the lithium batteries that are charged by the fuel cells. As long as oxygen and hydrogen are fed to the fuel cells, a dc voltage will be generated by the fuel cell to charge or maintain the voltage. This voltage is fed to an inverter, which in turn will provide the ac power for the drivetrain. Note in Fig. 2.24 that the vehicle also has the unique ability to capture braking energy and turn it into energy stored by a high-output battery for supplemental use. The fuel-cell car currently has a range of about 300 miles on a full hydrogen tank with fueling times as low as 3 minutes to match that of a typical gasoline tank. Of course, the most pleasing characteristic of the vehicle is that the only discharge is some residual water that can be used for cooling. In addition, sealed batteries will eventually deteriorate but fuel cells have a longer life because the “chemicals” (oxygen and hydrogen) are continually being replaced.

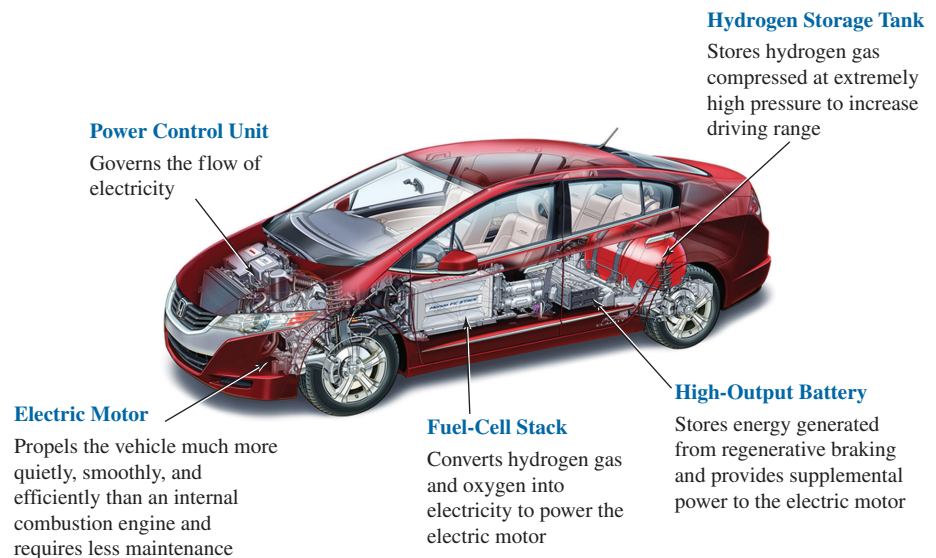

**FIG. 2.24**

*Honda FCX Clarity fuel-cell automobile.*

(Courtesy of American Honda Motor Co. Inc.)

## 2.6 AMPERE-HOUR RATING

The most important piece of data for any battery (other than its voltage rating) is its **ampere-hour (Ah) rating**. You have probably noted in the photographs of batteries in this chapter that both the voltage and the ampere-hour rating have been provided for each battery.



**The ampere-hour (Ah) rating provides an indication of how long a battery of fixed voltage will be able to supply a particular current.**

A battery with an ampere-hour rating of 100 will theoretically provide a current of 1 A for 100 hours, 10 A for 10 hours, or 100 A for 1 hour. Quite obviously, the greater the current, the shorter is the time. An equation for determining the length of time a battery will supply a particular current is the following:

$$\text{Life (hours)} = \frac{\text{ampere-hour (Ah) rating}}{\text{amperes drawn (A)}} \quad (2.11)$$

**EXAMPLE 2.5** How long will a 9 V transistor battery with an ampere-hour rating of 520 mAh provide a current of 20 mA?

**Solution:** Eq. (2.11):  $\text{Life} = \frac{520 \text{ mAh}}{20 \text{ mA}} = \frac{520}{20} \text{ h} = 26 \text{ h}$

**EXAMPLE 2.6** How long can a 1.5 V flashlight battery provide a current of 250 mA to light the bulb if the ampere-hour rating is 16 Ah?

**Solution:** Eq. (2.11):  $\text{Life} = \frac{16 \text{ Ah}}{250 \text{ mA}} = \frac{16}{250 \times 10^{-3}} \text{ h} = 64 \text{ h}$

## 2.7 BATTERY LIFE FACTORS

The previous section made it clear that the life of a battery is directly related to the magnitude of the current drawn from the supply. However, there are factors that affect the given ampere-hour rating of a battery, so we may find that a battery with an ampere-hour rating of 100 can supply a current of 10 A for 10 hours but can supply a current of 100 A for only 20 minutes rather than the full 1 hour calculated using Eq. (2.11). In other words,

***the capacity of a battery (in ampere-hours) will change with change in current demand.***

This is not to say that Eq. (2.11) is totally invalid. It can always be used to gain some insight into how long a battery can supply a particular current. However, be aware that there are factors that affect the ampere-hour rating. Just as with most systems, including the human body, the more we demand, the shorter is the time that the output level can be maintained. This is clearly verified by the curves in Fig. 2.25 for the Eveready Energizer D cell. As the constant-current drain increased, the ampere-hour rating decreased from about 18 Ah at 25 mA to around 12 Ah at 300 mA.

Another factor that affects the ampere-hour rating is the temperature of the unit and the surrounding medium. In Fig. 2.26, the capacity of the same battery plotted in Fig. 2.25 shows a peak value near the common room temperature of 68°F. At very cold temperatures and very warm temperatures, the capacity drops. Clearly, the ampere-hour rating will be provided at or near room temperature to give it a maximum value, but be aware that it will drop off with an increase or decrease in temperature. Most of us have noted that the battery in a car, radio, two-way radio, cellphone, flashlight, and so on seems to have less power in really cold weather. It would seem, then, that the battery capacity would increase

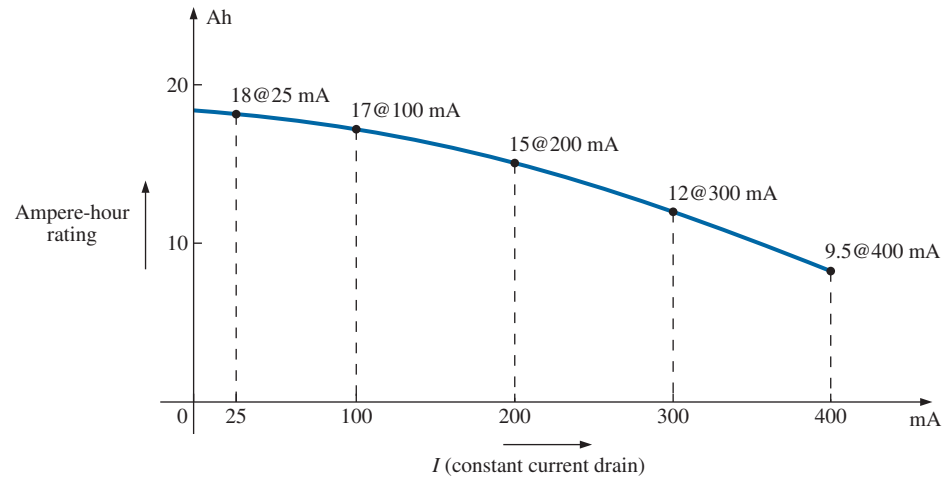

FIG. 2.25

Ampere-hour rating (capacity) versus drain current for an Energizer® D cell.

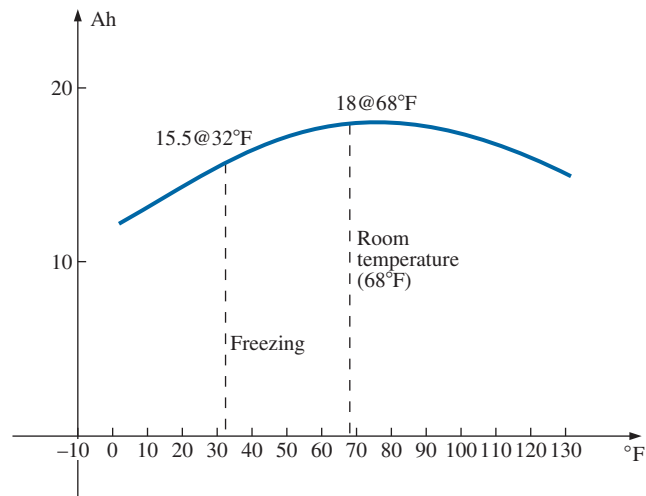

FIG. 2.26

Ampere-hour rating (capacity) versus temperature for an Energizer® D cell.

with higher temperatures—which, however, is not always the case. In general, therefore,

***the ampere-hour rating of a battery will decrease from the room-temperature level with very cold and very warm temperatures.***

Another interesting factor that affects the performance of a battery is how long it is asked to supply a particular voltage at a continuous drain current. Note the curves in Fig. 2.27, where the terminal voltage dropped at each level of drain current as the time period increased. The lower the current drain, the longer it could supply the desired current. At 100 mA, it was limited to about 100 hours near the rated voltage, but at 25 mA, it did not drop below 1.2 V until about 500 hours had passed. That is an increase in time of 5:1, which is significant. The result is that

***the terminal voltage of a battery will eventually drop (at any level of current drain) if the time period of continuous discharge is too long.***

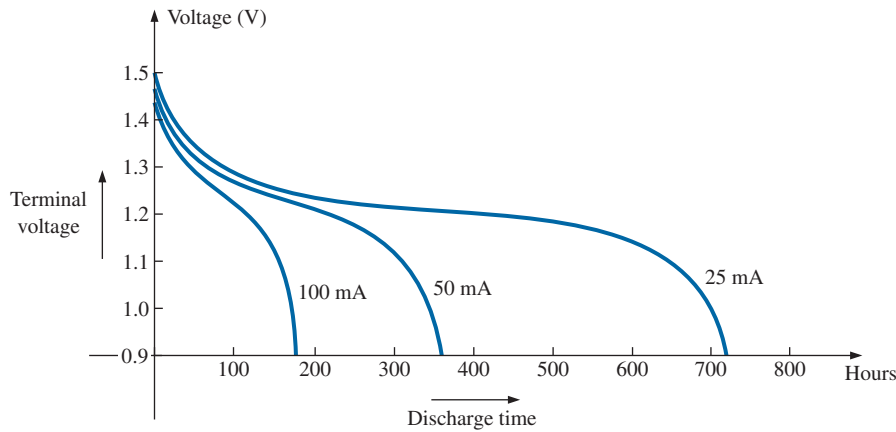
**FIG. 2.27**

Terminal voltage versus discharge time for specific drain currents for an Energizer® D cell.

## 2.8 CONDUCTORS AND INSULATORS

Different wires placed across the same two battery terminals allow different amounts of charge to flow between the terminals. Many factors, such as the density, mobility, and stability characteristics of a material, account for these variations in charge flow. In general, however,

**conductors are those materials that permit a generous flow of electrons with very little external force (voltage) applied.**

In addition,

**good conductors such as copper typically have only one electron in the valence (most distant from the nucleus) ring.**

Since **copper** is used most frequently, it serves as the standard of comparison for the relative conductivity in Table 2.1. Note that aluminum, which has seen some commercial use, has only 61% of the conductivity level of copper. The choice of material must be weighed against the cost and weight factors, however.

**Insulators are those materials that have very few free electrons and require a large applied potential (voltage) to establish a measurable current level.**

A common use of insulating material is for covering current-carrying wire, which, if uninsulated, could cause dangerous side effects. Power line workers wear rubber gloves and stand on rubber mats as safety measures when working on high-voltage transmission lines. A few different types of insulators and their applications appear in Fig. 2.28.

Be aware, however, that even the best insulator will break down (permit charge to flow through it) if a sufficiently large potential (voltage) is applied across it. The breakdown strengths of some common insulators are listed in Table 2.2. According to this table, for insulators with the same geometric shape, it would require  $270/30 = 9$  times as much potential to pass current through rubber as through air and approximately 67 times as much voltage to pass current through mica as through air.

**TABLE 2.1**

Relative conductivity of various materials.

Metal	Relative Conductivity (%)
Silver	105
Copper	<b>100</b>
Gold	70.5
Aluminum	61
Tungsten	31.2
Nickel	22.1
Iron	14
Constantan	3.52
Nichrome	1.73
Calorite	1.44

**TABLE 2.2**

Breakdown strength of some common insulators.

Material	Average Breakdown Strength (kV/cm)
Air	30
Porcelain	70
Oils	140
Bakelite®	150
Rubber	270
Paper (paraffin-coated)	500
Teflon®	600
Glass	900
Mica	2000

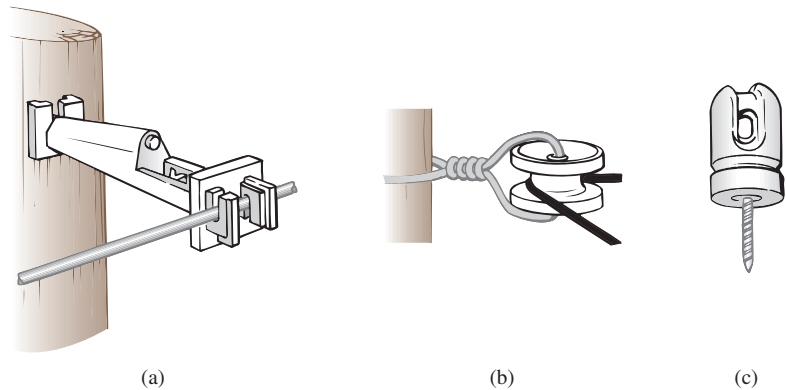

**FIG. 2.28**

*Various types of insulators and their applications. (a) Fi-Shock extender insulator; (b) Fi-Shock corner insulator; (c) Fi-Shock screw-in post insulator.*

## 2.9 SEMICONDUCTORS

***Semiconductors are a specific group of elements that exhibit characteristics between those of insulators and those of conductors.***

The prefix *semi*, included in the terminology, has the dictionary definition of *half*, *partial*, or *between*, as defined by its use. The entire electronics industry is dependent on this class of materials since the electronic devices and integrated circuits (ICs) are constructed of semiconductor materials. Although *silicon* (Si) is the most extensively employed material, *germanium* (Ge) and *gallium arsenide* (GaAs) are also used in many important high-speed electronic switching devices.

***Semiconductor materials typically have four electrons in the outermost valence ring.***

Semiconductors are further characterized as being photoconductive and having a negative temperature coefficient. Photoconductivity is a phenomenon in which the photons (small packages of energy) from incident light can increase the carrier density in the material and thereby the charge flow level. A negative temperature coefficient indicates that the resistance (a characteristic to be described in detail in the next chapter) decreases with an increase in temperature (opposite to that of most conductors). A great deal more will be said about semiconductors in the chapters to follow and in your basic electronics courses.

## 2.10 AMMETERS AND VOLTMETERS

It is important to be able to measure the current and voltage levels of an operating electrical system to check its operation, isolate malfunctions, and investigate effects impossible to predict on paper. As the names imply, **ammeters** are used to measure current levels; **voltmeters**, the potential difference between two points. If the current levels are usually of the order of milliamperes, the instrument will typically be referred to as a *milliammeter*, and if the current levels are in the microampere range, as a *microammeter*. Similar statements can be made for voltage levels. Throughout the industry, voltage levels are measured more frequently than current levels, primarily because measurement of the latter does not require that the network connections be disturbed.

The potential difference between two points can be measured by simply connecting the leads of the meter *across the two points*, as indicated in Fig. 2.29. An up-scale reading is obtained by placing the positive lead of the meter to the point of higher potential of the network and the common or negative lead to the point of lower potential. The reverse connection results in a negative reading or a below-zero indication.

Ammeters are connected as shown in Fig. 2.30. Since ammeters measure the rate of flow of charge, the meter must be placed in the network such that the charge flows through the meter. The only way this can be accomplished is to open the path in which the current is to be measured and place the meter between the two resulting terminals. For the configuration in Fig. 2.30, the voltage source lead (+) must be disconnected from the system and the ammeter inserted as shown. An up-scale reading will be obtained if the polarities on the terminals of the ammeter are such that the current of the system enters the positive terminal.

The introduction of any meter into an electrical/electronics system raises a concern about whether the meter will affect the behavior of the system. This question and others will be examined in Chapters 5 and 6 after additional terms and concepts have been introduced. For the moment, let it be said that since voltmeters and ammeters do have internal components, they will affect the network when introduced for measurement purposes. The design of each, however, is such that the impact is minimized.

There are instruments designed to measure just current or just voltage levels. However, the most common laboratory meters include the *volt-ohm-milliammeter* (VOM) and the *digital multimeter* (DMM), shown in Figs. 2.31 and 2.32, respectively. Both instruments measure voltage and current and a third quantity, resistance (introduced in the next chapter). The VOM uses an analog scale, which requires interpreting the position of a pointer on a continuous scale, while the DMM provides a display of numbers with decimal-point accuracy determined by the chosen scale.

The use of an analog continuous scale can take some practice, but analog scales still appear so frequently that one must become adept at reading the scale correctly. The laboratory experience is probably the best opportunity to practice the reading of such a scale, but for the moment

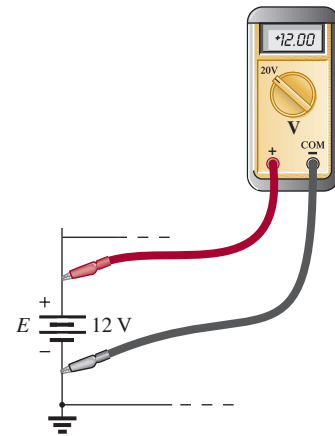

**FIG. 2.29**  
Voltmeter connection for an up-scale (+) reading.

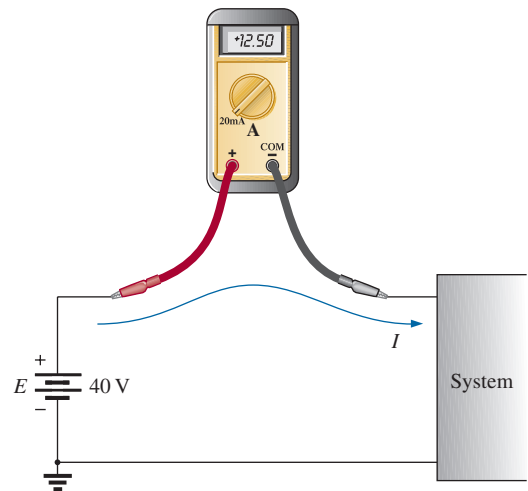

**FIG. 2.30**  
Ammeter connection for an up-scale (+) reading.



**FIG. 2.31**  
Volt-ohm-milliammeter (VOM) analog meter.  
(Andrew Scheck/Fotolia)



**FIG. 2.32**  
Digital multimeter (DMM).  
(Courtesy of Fluke Corporation)

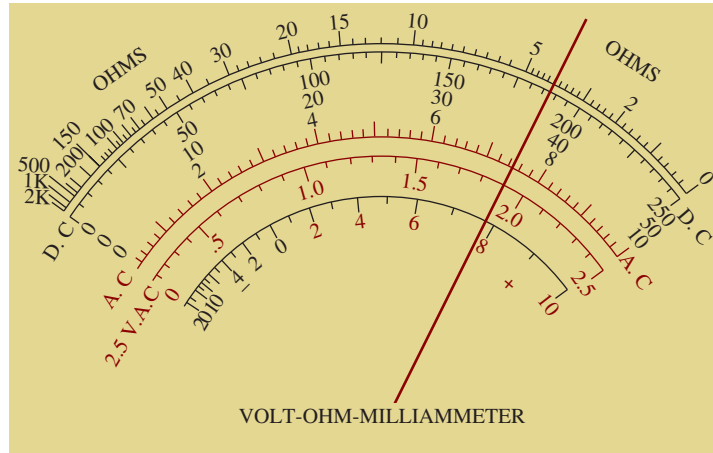

**FIG. 2.33**  
*Reading an analog scale.*

let us try to interpret the reading of the VOM shown in Fig. 2.33. First, you will note that the pointer passes over a number of scales. If reading the resistance (Chapter 3) of a resistive element, the top scale is used. If the meter is set on  $R \times 1$ , the resistance should be read as indicated. If the meter is set on  $R \times 10$ , the result must be increased by a factor of ten. Assuming  $R \times 1$  for our current discussion, we must first notice that the resistance scale increases from the right to the left. The pointer appears to be right over the heavy bar between 2 and 5. Since there are three distinct regions between the numbers 2 and 5, the first bar to the left of 2 must signify 3 and the next bar 4 to complete the sequence from 2 to 5. The needle is right over the bar representing 4 so the reading is obviously 4 ohms.

If the meter were set to read dc voltages, the band below the top resistance scale must be used. Now this scale increases from left to right with 250 V being the maximum voltage if the meter is set on  $V \times 1$ . For this scale the pointer is between 150 and 200 V. If we count the divisions between the two numbers, we find there are 10 divisions. If we divide the difference in voltage by the number of divisions, we obtain  $50 \text{ V}/10 \text{ div.}$  or 5 V per division. Counting from 150 V up, we find the pointer is 7.5 divisions above the 150 V level. The result is that the reading is at  $150 \text{ V} + (7.5 \text{ div.})(5 \text{ V/div.}) = 150 \text{ V} + 37.5 \text{ V} = 187.5 \text{ V}$ . It is a bit of struggle to make a simple reading but this is the process one should be able to perform with a high degree of confidence. If ac (Chapter 13) voltages were being measured on the  $V \times 1$  scale, then the red ac scale below the dc scale must be used. Again, the scale increases from left to right with the pointer between the 6- and 8-volt levels. Because the heavy bar between them must represent 7 V, the five divisions between 7 and 8 V must have divisions of  $1 \text{ V}/5 \text{ div.} = 0.2 \text{ V/div.}$  The pointer is very close to 2.5 divisions above 7 V, so the reading is approximately  $7 \text{ V} + (2.5 \text{ div.})(0.2 \text{ V/div.}) = 7 \text{ V} + 0.5 \text{ V} = 7.5 \text{ V}$ . Now in this case the pointer is really just to the left of the halfway point between the two bars, so the reading is closer to 7.45 V.

With all the extra effort required to read analog scales, why do we use them at all if we have digital meters that can read to hundredths-place accuracy? We do so because there are times when analog meters have characteristics that make them more efficient and safer to use. Consider the airline pilot and the huge dashboard in the cockpit with a range of



meters to monitor. The majority of the meters are analog and not digital. The reason for this choice is over time the mind can scan a range of meters and establish the correct position of each pointer in memory and, if one seems out of whack, it can be quickly identified. This task is not so easy if facing you are 20 digital meters with all kinds of numbers. In addition a swinging or bouncing pointer can quickly be identified. The pointer also quickly shows whether the undesirable movement is up or down—again not so easy when you have to remember the numbers associated with a stable condition.

As indicated above, the laboratory experience will provide practice in the use of both types of instruments.

## 2.11 APPLICATIONS

Throughout the text, Applications sections such as this one have been included to permit a further investigation of terms, quantities, or systems introduced in the chapter. The primary purpose of these Applications is to establish a link between the theoretical concepts of the text and the real, practical world. Although the majority of components that appear in a system may not have been introduced (and, in fact, some components will not be examined until more advanced studies), the topics were chosen very carefully and should be quite interesting to a new student of the subject matter. Sufficient comment is included to provide a surface understanding of the role of each part of the system, with the understanding that the details will come at a later date. Since exercises on the subject matter of the Applications do not appear at the end of the chapter, the content is designed not to challenge the student but rather to stimulate his or her interest and answer some basic questions such as how the system looks inside, what role specific elements play in the system, and, of course, how the system works. In essence, therefore, each Applications section provides an opportunity to begin to establish a practical background beyond simply the content of the chapter. Do not be concerned if you do not understand every detail of each application. Understanding will come with time and experience. For now, take what you can from the examples and then proceed with the material.

### Flashlight

Although the flashlight uses one of the simplest of electrical circuits, a few fundamentals about its operation do carry over to more sophisticated systems. First, and quite obviously, it is a dc system with a lifetime totally dependent on the state of the batteries and bulb. Unless it is the rechargeable type, each time you use it, you take some of the life out of it. For many hours, the brightness will not diminish noticeably. Then, however, as it reaches the end of its ampere-hour capacity, the light becomes dimmer at an increasingly rapid rate (almost exponentially). The standard two-battery flashlight is shown in Fig. 2.34(a) with its electrical schematic in Fig. 2.34(b). Each 1.5 V battery has an ampere-hour rating of about 18 as indicated in Fig. 2.13. The single-contact miniature flange-base bulb is rated at 2.5 V and 300 mA with good brightness and a lifetime of about 30 hours. Thirty hours may not seem like a long lifetime, but you have to consider how long you usually use a flashlight on each occasion. If we assume a 300 mA drain from the battery for the

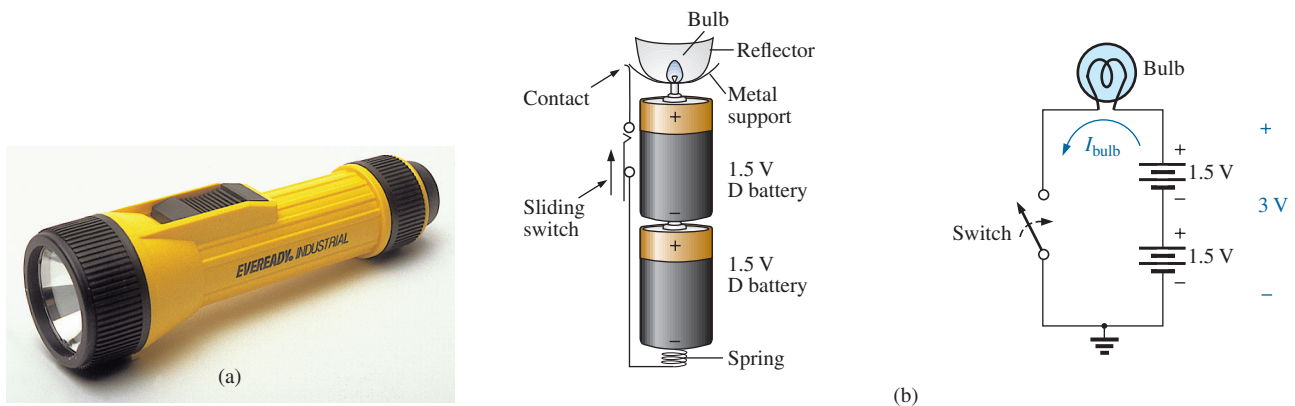

FIG. 2.34

(a) Eveready® D cell flashlight; (b) electrical schematic of flashlight of part (a).

bulb when in use, the lifetime of the battery, by Eq. (2.11), is about 60 hours. Comparing the 60-hour lifetime of the battery to the 30-hour life expectancy of the bulb suggests that we normally have to replace bulbs more frequently than batteries.

However, most of us have experienced the opposite effect. We can change batteries two or three times before we need to replace the bulb. This is simply one example of the fact that one cannot be guided solely by the specifications of each component of an electrical design. The operating conditions, terminal characteristics, and details about the actual response of the system for short and long periods of time must be considered. As mentioned earlier, the battery loses some of its power each time it is used. Although the terminal voltage may not change much at first, its ability to provide the same level of current drops with each usage. Further, batteries slowly discharge due to “leakage currents” even if the switch is not on. The air surrounding the battery is not “clean” in the sense that moisture and other elements in the air can provide a conduction path for leakage currents through the air through the surface of the battery itself, or through other nearby surfaces, and the battery eventually discharges. How often have we left a flashlight with new batteries in a car for a long period of time only to find the light very dim or the batteries dead when we need the flashlight the most? An additional problem is acid leaks that appear as brown stains or corrosion on the casing of the battery. These leaks also affect the life of the battery. Further, when the flashlight is turned on, there is an initial surge in current that drains the battery more than continuous use for a period of time. In other words, continually turning the flashlight on and off has a very detrimental effect on its life. We must also realize that the 30 hour rating of the bulb is for continuous use, that is, 300 mA flowing through the bulb for a continuous 30 hours. Certainly, the filament in the bulb and the bulb itself will get hotter with time, and this heat has a detrimental effect on the filament wire. When the flashlight is turned on and off, it gives the bulb a chance to cool down and regain its normal characteristics, thereby avoiding any real damage. Therefore, with normal use we can expect the bulb to last longer than the 30 hours specified for continuous use.

Even though the bulb is rated for 2.5 V operation, it would appear that the two batteries would result in an applied voltage of 3 V, which suggests poor operating conditions. However, a bulb rated at 2.5 V can



easily handle 2.5 V to 3 V. In addition, as was pointed out in this chapter, the terminal voltage drops with the current demand and usage. Under normal operating conditions, a 1.5 V battery is considered to be in good condition if the loaded terminal voltage is 1.3 V to 1.5 V. When it drops to the range from 1 V to 1.1 V, it is weak, and when it drops to the range from 0.8 V to 0.9 V, it has lost its effectiveness.

Be aware that the total supplied voltage of 3 V will be obtained only if the batteries are connected as shown in Fig. 2.34(b). Accidentally placing the two positive terminals together will result in a total voltage of 0 V, and the bulb will not light at all. *For the vast majority of systems with more than one battery, the positive terminal of one battery will always be connected to the negative terminal of another. For all low-voltage batteries, the end with the nipple is the positive terminal, and the end with the flat end is the negative terminal. In addition, the flat or negative end of a battery is always connected to the battery casing with the helical coil to keep the batteries in place. The positive end of the battery is always connected to a flat terminal connection or the element to be operated.* If you look carefully at the bulb, you will find that the nipple connected to the positive end of the battery is insulated from the jacket around the base of the bulb. The jacket is the second terminal of the battery used to complete the circuit through the on/off switch.

If a flashlight fails to operate properly, the first thing to check is the state of the batteries. It is best to replace both batteries at once. A system with one good battery and one nearing the end of its life will result in pressure on the good battery to supply the current demand, and, in fact, the bad battery will actually be a drain on the good battery. Next, check the condition of the bulb by checking the filament to see whether it has opened at some point because a long-term, continuous current level occurred or because the flashlight was dropped. If the battery and bulb seem to be in good shape, the next area of concern is the contacts between the positive terminal and the bulb and the switch. Cleaning both with emery cloth often eliminates this problem.

## 12 V Car Battery Charger

Battery chargers are a common household piece of equipment used to charge everything from small flashlight batteries to heavy-duty, marine, lead-acid batteries. Since all are plugged into a 120 V ac outlet such as found in the home, the basic construction of each is quite similar. In every charging system, a *transformer* (Chapter 23) must be included to reduce the ac voltage to a level appropriate for the charging dc level to be established. A *diode* (also called *rectifier*) arrangement must be included to convert the ac voltage, which varies with time, to an average dc level such as described in this chapter. Diodes and/or rectifiers will be discussed in detail in your first electronics course. Some dc chargers also include a *regulator* to provide an improved dc level (one that varies less with time or load). The car battery charger, one of the most common, is described here.

The outside appearance and the internal construction of a DieHard 2 A/10 A AMP Manual Battery Charger are provided in Fig. 2.35. Note in Fig. 2.35(b) that the transformer (as in most chargers) takes up most of the internal space. The additional air space and the holes in the casing are there to ensure an outlet for the heat that will develop due to the resulting current levels.

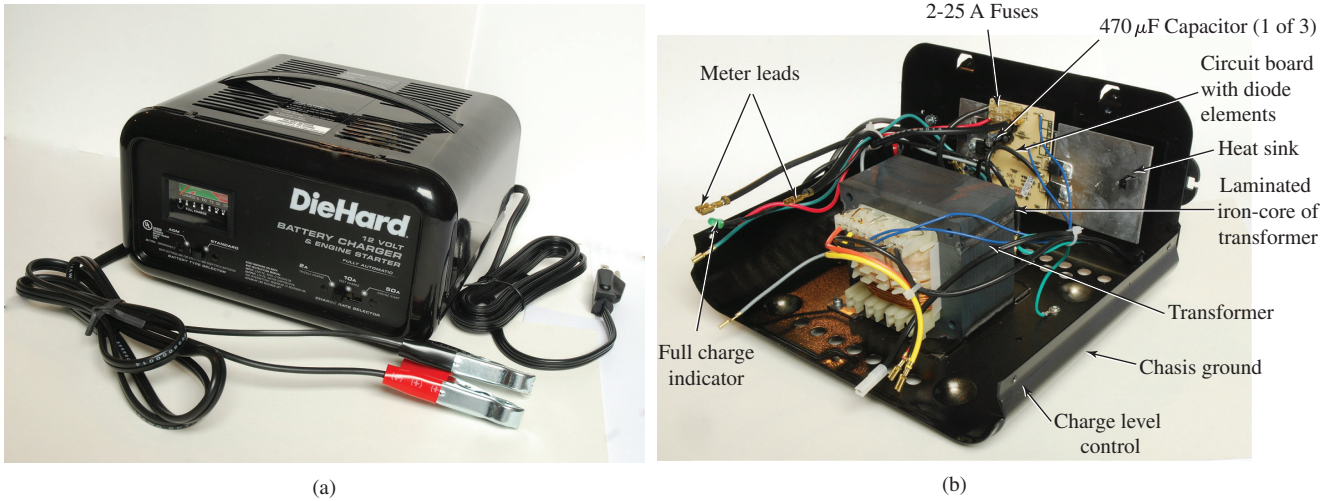

**FIG. 2.35**  
 Battery charger: (a) external appearance; (b) internal construction.  
 (Don Johnson Photo)

The schematic in Fig. 2.36 includes all the basic components of the charger. Note first that the 120 V ac from the outlet are applied directly across the primary of the transformer. The charging rate of 2 A or 10 A is determined by the switch, which simply controls how many turns of the primary will be in the circuit for the chosen charging rate. If the battery is charging at the 2 A level, the full primary will be in the circuit, and the ratio of the turns in the primary to the turns in the secondary will be a maximum. If it is charging at the 10 A level, fewer turns of the primary are in the circuit, and the ratio drops. When you study transformers, you will find that the voltage at the primary and secondary is directly related to the *turns ratio*. If the ratio from primary to secondary drops, the voltage drops also. The reverse effect occurs if the turns on the secondary exceed those on the primary.

The general appearance of the waveforms appears in Fig. 2.36 for the 10 A charging level. Note that so far, the ac voltage has the same

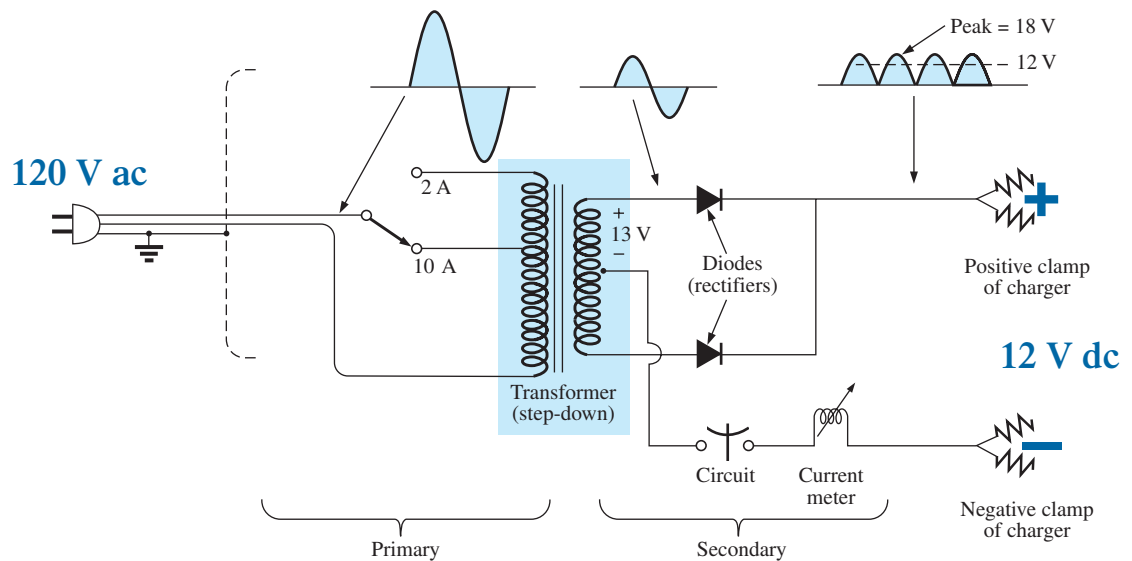

**FIG. 2.36**  
 Electrical schematic for the battery charger of Fig. 2.35.

wave shape across the primary and secondary. The only difference is in the peak value of the waveforms. Now the diodes take over and convert the ac waveform, which has zero average value (the waveform above equals the waveform below), to one that has an average value (all above the axis) as shown in the same figure. For the moment simply recognize that diodes are semiconductor electronic devices that permit only conventional current to flow through them in the direction indicated by the arrow in the symbol. Even though the waveform resulting from the diode action has a pulsing appearance with a peak value of about 18 V, it charges the 12 V battery whenever its voltage is greater than that of the battery, as shown by the shaded area. Below the 12 V level, the battery cannot discharge back into the charging network because the diodes permit current flow in only one direction.

In particular, note in Fig. 2.35(b) the large plate that carries the current from the rectifier (diode) configuration to the positive terminal of the battery. Its primary purpose is to provide a *heat sink* (a place for the heat to be distributed to the surrounding air, such as a piece of aluminum with fins screwed to the diode) for the diode configuration. Otherwise, the diodes could eventually melt down and self-destruct due to the resulting high current levels. Each component of Fig. 2.36 has been carefully labeled in Fig. 2.35(b) for reference.

When current is first applied to a battery at the 10 A charge rate, the current demand as indicated by the meter on the face of the instrument may rise to 11 A or almost 12 A. However, the level of current decreases as the battery charges until it drops to a level of 2 A or 3 A. For units such as this that do not have an automatic shutoff, it is important to disconnect the charger when the current drops to the fully charged level; otherwise, the battery becomes overcharged and may be damaged. A battery that is at its 50% level can take as long as 10 hours to charge, so don't expect it to be a 10-minute operation. In addition, if a battery is in very bad shape with a lower-than-normal voltage, the initial charging current may be too high for the design. To protect against such situations, the circuit breaker opens and stops the charging process. Because of the high current levels, it is important that the directions provided with the charger be carefully read and applied.

The 50 A option on the face of the charger is for starting situations. This option can be used for limited periods of time if the battery voltage is too low. It can only be used for 10-second periods spaced by 3-minute periods for cooldown of the charger and battery.

## Answering Machines/Phones dc Supply

A wide variety of systems in the home and office receive their dc operating voltage from an ac/dc conversion system plugged right into a 120 V ac outlet. Laptop computers, answering machines/phones, radios, clocks, cellular phones, CD players, and so on, all receive their dc power from a packaged system such as shown in Fig. 2.37. The conversion from ac to dc occurs within the unit, which is plugged directly into the outlet. The dc voltage is available at the end of the long wire, which is designed to be plugged into the operating unit. As small as the unit may be, it contains basically the same components as in the battery charger in Fig. 2.35.

In Fig. 2.38, you can see the transformer used to cut the voltage down to appropriate levels (again the largest component of the system). Note that two diodes establish a dc level, and a capacitive filter (Chapter 10) is added to smooth out the dc voltage as shown. The system can be

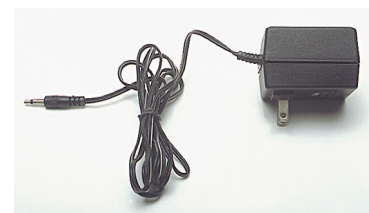

**FIG. 2.37**  
Answering machine/phone  
9 V dc supply.

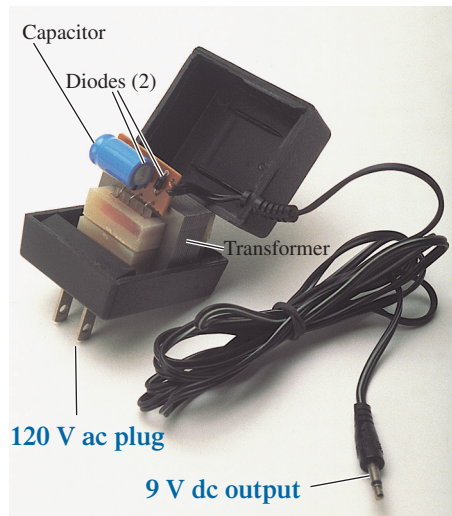

FIG. 2.38

Internal construction of the 9 V dc supply in Fig. 2.37.

relatively small because the operating current levels are quite small, permitting the use of thin wires to construct the transformer and limit its size. The lower currents also reduce the concerns about heating effects, permitting a small housing structure. The unit in Fig. 2.38, rated at 9 V at 200 mA, is commonly used to provide power to answering machines/phones. Further smoothing of the dc voltage is accomplished by a regulator built into the receiving unit. Its placement in the receiving unit reduces the possibility of picking up noise and oscillations along the long wire from the conversion unit to the operating unit, and it ensures that the full rated voltage is available at the unit itself, not a lesser value due to losses along the line.

## PROBLEMS

### SECTION 2.2 Atoms and Their Structure

- The numbers of orbiting electrons in aluminum and silver are 13 and 47, respectively. Draw the electronic configuration for each, and discuss briefly why each is a good conductor.
  - Using the Internet, find the atomic structure of gold and explain why it is an excellent conductor of electricity.
- Find the force of attraction in newtons between the charges  $Q_1$  and  $Q_2$  in Fig. 2.39 when
  - $r = 1$  m
  - $r = 3$  m
  - $r = 10$  m
  - Did the force drop off quickly with an increase in distance?

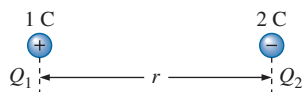

FIG. 2.39

Problem 2.

- Find the force of repulsion in newtons between  $Q_1$  and  $Q_2$  in Fig. 2.40 when
  - $r = 1$  ft
  - $r = 10$  ft
  - $r = 100$  yd
  - Comment on the change in magnitude of the force as the distance between the charges was dramatically increased.

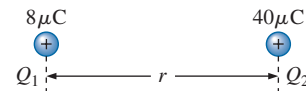

FIG. 2.40

Problem 3.

- Plot the force of attraction (in newtons) versus separation (in inches) between two unlike charges of  $2 \mu\text{C}$ . Use a range of 1 in. to 10 in. in 1 in. increments. Comment on the shape of the curve. Is it linear or nonlinear? What does it tell you about plotting a function whose magnitude is affected by a squared term in the denominator of the equation?
  - Using the plot of part (a), find the force of attraction at a 2.5 in. separation.
  - Calculate the force of attraction with a 2.5 in. separation and compare with the result of part (b).
- For two similar charges the force  $F_1$  exists for a separation of  $r$  meters. If the distance is increased to  $2r$ , find the new level of force  $F_2$  in terms of the original force and the distance involved.
- Determine the distance between two charges of  $30 \mu\text{C}$  if the force between the two charges is  $4.5 \times 10^4$  N.
- Two charged bodies  $Q_1$  and  $Q_2$ , when separated by a distance of 2 m, experience a force of repulsion equal to 1.8 N.
  - What will the force of repulsion be when they are 10 m apart?
  - If the ratio  $Q_1/Q_2 = 1/2$ , find  $Q_1$  and  $Q_2$  ( $r = 10$  m).



### SECTION 2.3 Voltage

8. What is the voltage between two points if 3.4 J of energy are required to move 12  $\mu\text{C}$  between the two points?
9. If the potential difference between two points is 50 V, how much energy is expended to bring 4 mC from one point to the other?
10. Find the charge in coulombs that requires 400  $\mu\text{J}$  of energy to be moved through a potential difference of 40 V.
11. How much charge passes through a radio battery of 9 V if the energy expended is 620 mJ?
- \*12.
  - a. How much energy in electron volts is required to move 1 trillion (1 million million) electrons through a potential difference of 40 V?
  - b. How many joules of energy does the result of part (a) represent?
  - c. Compare results (a) and (b). What can you say about the use of joules and electron volts as a unit of measure. Under what conditions should they be applied?

### SECTION 2.4 Current

13. Find the current in amperes if 96 mC of charge pass through a wire in 8.4 s.
14. If 600 C of charge pass through a wire in 4 min, find the current in amperes.
15. If a current of 40 mA exists for 1.2 min, how many coulombs of charge have passed through the wire?
16. How many coulombs of charge pass through a lamp in 1.2 min if the current is constant at 250 mA?
17. If the current in a conductor is constant at 2 mA, how much time is required for 6 mC to pass through the conductor?
18. If  $21.847 \times 10^{+18}$  electrons pass through a wire in 12 s, find the current.
19. How many electrons pass through a conductor in 5 min and 30 s if the current is 4 mA?
20. Will a fuse rated at 1 A “blow” if 86 C pass through it in 1.2 min?
- \*21. If  $0.92 \times 10^{+16}$  electrons pass through a wire in 50 ms, find the current.
- \*22. Which would you prefer?
  - a. A penny for every electron that passes through a wire in 0.01  $\mu\text{s}$  at a current of 2 mA, or
  - b. A dollar for every electron that passes through a wire in 1.5 ns if the current is 100  $\mu\text{A}$ .
- \*23. If a conductor with a current of 300 mA passing through it converts 60 J of electrical energy into heat in 40 s, what is the potential drop across the conductor?
- \*24. Charge is flowing through a conductor at the rate of 420 C/min. If 742 J of electrical energy are converted to heat in 30 s, what is the potential drop across the conductor?
- \*25. The potential difference between two points in an electric circuit is 24 V. If 0.8 J of energy were dissipated in a period of 6 ms, what would the current be between the two points?

### SECTION 2.6 Ampere-Hour Rating

26. What current will a battery with an Ah rating of 120 theoretically provide for 10 h?
27. What is the Ah rating of a battery that can provide 0.64 A for 80 h?
28. For how many hours will a battery with an Ah rating of 72 theoretically provide a current of 1.80 A?
29. A standard 12 V car battery has an ampere-hour rating of 45 Ah, whereas a heavy-duty battery has a rating of 75 Ah. How would you compare the energy levels of each and the available current for starting purposes?
30. At what current drain does the ampere-hour rating of the Energizer D Cell of Fig. 2.25 drop to 75% of its value at 25 mA?
31. What is the percentage loss in ampere-hour rating from room temperature to freezing for the Energizer D Cell of Fig. 2.26?
32. Using the graph of Fig. 2.27, how much longer can you maintain 1.2 V at a discharge rate of 25 mA compared to discharging at 100 mA?
- \*33. A portable television using a 12 V, 4 Ah rechargeable battery can operate for a period of about 8 h. What is the average current drawn during this period? What is the energy expended by the battery in joules?

### SECTION 2.8 Conductors and Insulators

34. Discuss two properties of the atomic structure of copper that make it a good conductor.
35. Explain the terms *insulator* and *breakdown strength*.
36. List three uses of insulators not mentioned in Section 2.8.
37.
  - a. Using Table 2.2, determine the level of applied voltage necessary to establish conduction through 1/2 in. of air.
  - b. Repeat part (a) for 1/2 in. of rubber.
  - c. Compare the results of parts (a) and (b).

### SECTION 2.9 Semiconductors

38. What is a semiconductor? How does it compare with a conductor and an insulator?
39. Consult a semiconductor electronics text and note the extensive use of germanium and silicon semiconductor materials. Review the characteristics of each material.

### SECTION 2.10 Ammeters and Voltmeters

40. What are the significant differences in the way ammeters and voltmeters are connected?
41. Compare analog and digital scales:
  - a. Which are you more comfortable with? Why?
  - b. Which can usually provide a higher degree of accuracy?
  - c. Can you think of any advantages of the analog scale over a digital scale? Be aware that the majority of scales in a plane's cockpit or in the control room of major power plants are analog.
  - d. Do you believe it is necessary to become proficient in reading analog scales? Why?



## GLOSSARY

- Ammeter** An instrument designed to read the current through elements in series with the meter.
- Ampere (A)** The SI unit of measurement applied to the flow of charge through a conductor.
- Ampere-hour (Ah) rating** The rating applied to a source of energy that will reveal how long a particular level of current can be drawn from that source.
- Cell** A fundamental source of electrical energy developed through the conversion of chemical or solar energy.
- Conductors** Materials that permit a generous flow of electrons with very little voltage applied.
- Conventional flow** The movement of charge through a conductor defined by the positive charge.
- Copper** A material possessing physical properties that make it particularly useful as a conductor of electricity.
- Coulomb (C)** The fundamental SI unit of measure for charge. It is equal to the charge carried by  $6.242 \times 10^{18}$  electrons.
- Coulomb's law** An equation defining the force of attraction or repulsion between two charges.
- Current** The flow of charge resulting from the application of a difference in potential between two points in an electrical system.
- dc current source** A source that will provide a fixed current level even though the load to which it is applied may cause its terminal voltage to change.
- dc generator** A source of dc voltage available through the turning of the shaft of the device by some external means.
- Direct current (dc)** Current having a single direction (unidirectional) and a fixed magnitude over time.
- Electrolysis** The process of passing a current through an electrolyte to break it down into its fundamental components.
- Electrolytes** The contact element and the source of ions between the electrodes of the battery.
- Electron** The particle with negative polarity that orbits the nucleus of an atom.
- Electron flow** The movement of charge through a conductor defined by the negative charge.
- Electron volt** A unit of energy defined by the movement of an electron through a potential difference of one volt.
- Free electron** An electron unassociated with any particular atom, relatively free to move through a crystal lattice structure under the influence of external forces.
- Fuel cell** A nonpolluting source of energy that can establish current through a load by simply applying the correct levels of hydrogen and oxygen.
- Insulators** Materials in which a very high voltage must be applied to produce any measurable current flow.
- Neutron** The particle having no electrical charge found in the nucleus of the atom.
- Nucleus** The structural center of an atom that contains both protons and neutrons.
- Positive ion** An atom having a net positive charge due to the loss of one of its negatively charged electrons.
- Potential difference** The algebraic difference in potential (or voltage) between two points in an electrical system.
- Potential energy** The energy that a mass possesses by virtue of its position.
- Primary cell** Sources of voltage that cannot be recharged.
- Proton** The particle of positive polarity found in the nucleus of an atom.
- Rectification** The process by which an ac signal is converted to one that has an average dc level.
- Secondary cell** Sources of voltage that can be recharged.
- Semiconductor** A material having a conductance value between that of an insulator and that of a conductor. Of significant importance in the manufacture of electronic devices.
- Solar cell** Sources of voltage available through the conversion of light energy (photons) into electrical energy.
- Specific gravity** The ratio of the weight of a given volume of a substance to the weight of an equal volume of water at 4°C.
- Volt (V)** The unit of measurement applied to the difference in potential between two points. If 1 joule of energy is required to move 1 coulomb of charge between two points, the difference in potential is said to be 1 volt.
- Voltage** The term applied to the difference in potential between two points as established by a separation of opposite charges.
- Voltmeter** An instrument designed to read the voltage across an element or between any two points in a network.

# Resistance

# 3

## Objectives

- Become familiar with the parameters that determine the resistance of an element and be able to calculate the resistance from the given dimensions and material characteristics.
- Understand the effects of temperature on the resistance of a material and how to calculate the change in resistance with temperature.
- Develop some understanding of superconductors and how they can affect future development in the industry.
- Become familiar with the broad range of commercially available resistors and how to read the value of each from the color code or labeling.
- Become aware of a variety of elements such as thermistors, photoconductive cells, and varistors and how their terminal resistance is controlled.

## 3.1 INTRODUCTION

In the previous chapter, we found that placing a voltage across the simplest of circuits results in a flow of charge through the circuit. The question remains, however, What determines the level of current that results when a particular voltage is applied? Why is the current heavier in some circuits than in others? The answers lie in the fact that there is an opposition to the flow of charge in the system that depends on the components of the circuit. This opposition to the flow of charge through an electrical circuit, called **resistance**, has the units of **ohms** and uses the Greek letter *omega* ( $\Omega$ ) as its symbol. The graphic symbol for resistance, which resembles the cutting edge of a saw, is provided in Fig. 3.1.

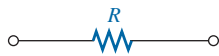
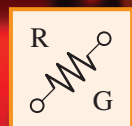

FIG. 3.1

Resistance symbol and notation.

This opposition, due primarily to collisions and friction between the free electrons and other electrons, ions, and atoms in the path of motion, converts the supplied electrical energy into **heat** that raises the temperature of the electrical component and surrounding medium. The heat you feel from an electrical heater is simply due to current passing through a high-resistance material.

Each material with its unique atomic structure reacts differently to pressures to establish current through its core. Conductors that permit a generous flow of charge with little external pressure have low resistance levels, while insulators have high resistance characteristics.



### 3.2 RESISTANCE: CIRCULAR WIRES

The resistance of any material is due primarily to four factors:

1. **Material**
2. **Length**
3. **Cross-sectional area**
4. **Temperature of the material**

As noted in Section 3.1, the atomic structure determines how easily a free electron will pass through a material. The longer the path through which the free electron must pass, the greater is the resistance factor. Free electrons pass more easily through conductors with larger cross-sectional areas. In addition, the higher the temperature of the conductive materials, the greater is the internal vibration and motion of the components that make up the atomic structure of the wire, and the more difficult it is for the free electrons to find a path through the material.

The first three elements are related by the following basic equation for resistance:

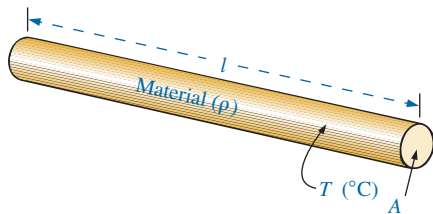

$$R = \rho \frac{l}{A} \quad \rho = \text{CM-}\Omega/\text{ft at } T = 20^\circ\text{C}$$

$$l = \text{feet}$$

$$A = \text{area in circular mils (CM)}$$
(3.1)

**FIG. 3.2**

Factors affecting the resistance of a conductor.

**TABLE 3.1**

Resistivity ( $\rho$ ) of various materials.

Material	$\rho$ (CM- $\Omega$ /ft)@20°C
Silver	9.9
<b>Copper</b>	<b>10.37</b>
Gold	14.7
Aluminum	17.0
Tungsten	33.0
Nickel	47.0
Iron	74.0
Constantan	295.0
Nichrome	600.0
Calorite	720.0
Carbon	21,000.0

with each component of the equation defined by Fig. 3.2.

The material is identified by a factor called the **resistivity**, which uses the Greek letter *rho* ( $\rho$ ) as its symbol and is measured in CM- $\Omega$ /ft. Its value at a temperature of 20°C (room temperature = 68°F) is provided in Table 3.1 for a variety of common materials. Since the larger the resistivity, the greater is the resistance to setting up a flow of charge, it appears as a multiplying factor in Eq. (3.1); that is, it appears in the numerator of the equation. The effect of higher and lower temperatures is considered in Section 3.4.

*It is important to realize at this point that since the resistivity is provided at room temperature, Eq. (3.1) is applicable only at that temperature.*

Since the resistivity is in the numerator of Eq. (3.1),

**the higher the resistivity, the greater is the resistance of a conductor**

as shown for two conductors of the same length in Fig. 3.3(a).

Further,

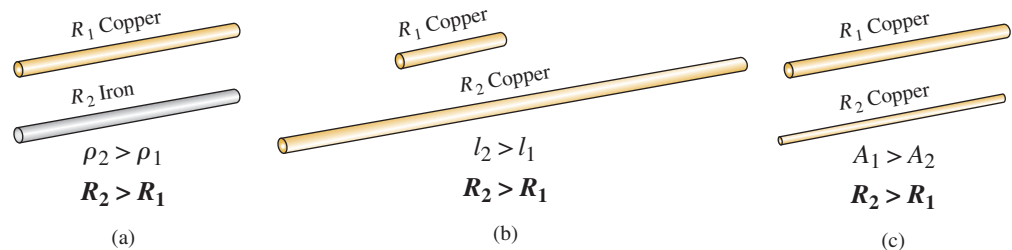

**FIG. 3.3**

Cases in which  $R_2 > R_1$ . For each case, all remaining parameters that control the resistance level are the same.

**the longer the conductor, the greater is the resistance**

since the length also appears in the numerator of Eq. (3.1). Note Fig. 3.3(b).

Finally,

**the greater the area of a conductor, the less is the resistance**

because the area appears in the denominator of Eq. (3.1). Note Fig. 3.3(c).

**Circular Mils (CM)**

In Eq. (3.1), the area is measured in a quantity called **circular mils (CM)**. It is the quantity used in most commercial wire tables, and thus it needs to be carefully defined. The *mil* is a unit of measurement for length and is related to the inch by

$$1 \text{ mil} = \frac{1}{1000} \text{ in.}$$

or

$$1000 \text{ mils} = 1 \text{ in.}$$

In general, therefore, the mil is a very small unit of measurement for length. There are 1000 mils in an inch, or 1 mil is only 1/1000 of an inch. It is a length that is not visible with the naked eye, although it can be measured with special instrumentation. The phrase *milling* used in steel factories is derived from the fact that a few mils of material are often removed by heavy machinery such as a lathe, and the thickness of steel is usually measured in mils.

By definition,

**a wire with a diameter of 1 mil has an area of 1 CM**

as shown in Fig. 3.4.

An interesting result of such a definition is that the area of a circular wire in circular mils can be defined by the following equation:

$$A_{CM} = (d_{mils})^2 \tag{3.2}$$

Verification of this equation appears in Fig. 3.5, which shows that a wire with a diameter of 2 mils has a total area of 4 CM, and a wire with a diameter of 3 mils has a total area of 9 CM.

Remember, to compute the area of a wire in circular mils when the diameter is given in inches, first convert the diameter to mils by simply writing the diameter in decimal form and moving the decimal point three places to the right. For example,

$$\frac{1}{8} \text{ in.} = \underset{\substack{\curvearrowright \\ 3 \text{ places}}}{0.125} \text{ in.} = 125 \text{ mils}$$

Then the area is determined by

$$A_{CM} = (d_{mils})^2 = (125 \text{ mils})^2 = \mathbf{15,625 \text{ CM}}$$

Sometimes when you are working with conductors that are not circular, you will need to convert square mils to circular mils, and vice versa. Applying the basic equation for the area of a circle and substituting a diameter of 1 mil results in

$$A = \frac{\pi d^2}{4} = \frac{\pi}{4} (1 \text{ mil})^2 = \frac{\pi}{4} \text{ sq mils} \stackrel{\text{by definition}}{\equiv} 1 \text{ CM}$$

from which we can conclude the following:

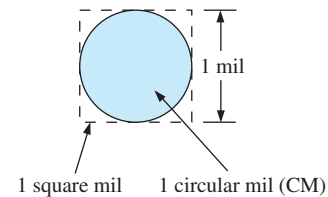

**FIG. 3.4**  
Defining the circular mil (CM).

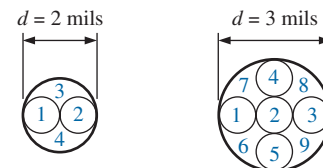

$$A = (2 \text{ mils})^2 = 4 \text{ CM} \quad A = (3 \text{ mils})^2 = 9 \text{ CM}$$

**FIG. 3.5**  
Verification of Eq. (3.2):  $A_{CM} = (d_{mils})^2$



$$1 \text{ CM} = \frac{\pi}{4} \text{ sq mils} \tag{3.3}$$

or

$$1 \text{ sq mil} = \frac{4}{\pi} \text{ CM} \tag{3.4}$$

**EXAMPLE 3.1** What is the resistance of a 100 ft length of copper wire with a diameter of 0.020 in. at 20°C?

**Solution:**

$$\rho = 10.37 \frac{\text{CM}\cdot\Omega}{\text{ft}} \text{ and } 0.020 \text{ in.} = 20 \text{ mils}$$

$$A_{\text{CM}} = (d_{\text{mils}})^2 = (20 \text{ mils})^2 = 400 \text{ CM}$$

$$R = \rho \frac{l}{A} = \frac{(10.37 \text{ CM}\cdot\Omega/\text{ft})(100 \text{ ft})}{400 \text{ CM}}$$

$$R = 2.59 \Omega$$

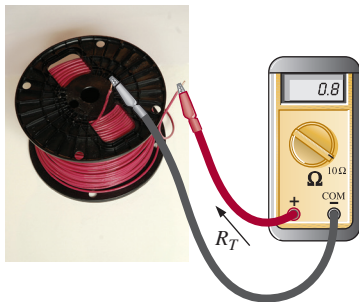

(Don Johnson Photo)

**FIG. 3.6**  
Example 3.2.

**EXAMPLE 3.2** An undetermined number of feet of wire have been used from the 500' spool of wire in Fig. 3.6. Find the length of the remaining copper wire if the diameter is 1/16 in. and the resistance is 0.8 Ω.

**Solution:**

$$\rho = 10.37 \text{ CM}\cdot\Omega/\text{ft} \text{ and } \frac{1}{16} \text{ in.} = 0.0625 \text{ in.} = 62.5 \text{ mils}$$

$$A_{\text{CM}} = (d_{\text{mils}})^2 = (62.5 \text{ mils})^2 = 3906.25 \text{ CM}$$

$$R = \rho \frac{l}{A} \Rightarrow l = \frac{RA}{\rho} = \frac{(0.8\Omega)(3906.25 \text{ CM})}{10.37 \frac{\text{CM}\cdot\Omega}{\text{ft}}} = \frac{3125}{10.37}$$

$$l = 301.35 \text{ ft}$$

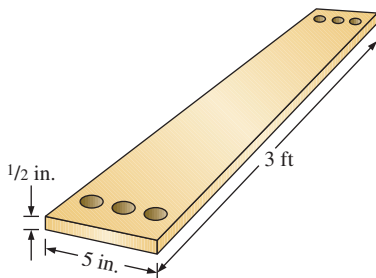

**FIG. 3.7**  
Example 3.3.

**EXAMPLE 3.3** What is the resistance of a copper bus-bar, as used in the power distribution panel of a high-rise office building, with the dimensions indicated in Fig. 3.7?

**Solution:**

$$A_{\text{CM}} \left\{ \begin{array}{l} 5.0 \text{ in.} = 5000 \text{ mils} \\ \frac{1}{2} \text{ in.} = 500 \text{ mils} \\ A = (5000 \text{ mils})(500 \text{ mils}) = 2.5 \times 10^6 \text{ sq mils} \\ = 2.5 \times 10^6 \text{ sq mils} \left( \frac{4/\pi \text{ CM}}{1 \text{ sq mil}} \right) \\ A = 3.183 \times 10^6 \text{ CM} \end{array} \right.$$

$$R = \rho \frac{l}{A} = \frac{(10.37 \text{ CM}\cdot\Omega/\text{ft})(3 \text{ ft})}{3.183 \times 10^6 \text{ CM}} = \frac{31.11}{3.183 \times 10^6}$$

$$R = 9.774 \times 10^{-6} \Omega$$

(quite small,  $0.000009774 \Omega \cong 0 \Omega$ )

You will learn in the following chapters that the lower the resistance of a conductor, the lower are the losses in conduction from the source to the load. Similarly, since resistivity is a major factor in determining the resistance of a conductor, the lower the resistivity, the lower is the resistance for the same-size conductor. It would appear from Table 3.1 that silver, copper, gold, and aluminum would be the best conductors and the most common. In general, there are other factors, however, such as **malleability** (ability of a material to be shaped), **ductility** (ability of a material to be drawn into long, thin wires), temperature sensitivity, resistance to abuse, and, of course, cost, that must all be weighed when choosing a conductor for a particular application.

In general, copper is the most widely used material because it is quite malleable, ductile, and available; has good thermal characteristics; and is less expensive than silver or gold. It is certainly not cheap, however. Contractors always ensure that the copper wiring has been removed before leveling a building because of its salvage value. Aluminum was once used for general wiring because it is cheaper than copper, but its thermal characteristics created some difficulties. The heating due to current flow and the cooling that occurred when the circuit was turned off resulted in expansion and contraction of the aluminum wire to the point where connections eventually loosened, resulting in dangerous side effects. Aluminum is still used today, however, in areas such as integrated circuit manufacturing and in situations where the connections can be made secure. Silver and gold are, of course, much more expensive than copper or aluminum, but the cost is justified for certain applications. Silver has excellent plating characteristics for surface preparations, and gold is used quite extensively in integrated circuits. Tungsten has a resistivity three times that of copper, but there are occasions when its physical characteristics (durability, hardness) are the overriding considerations.

### 3.3 WIRE TABLES

The wire table was designed primarily to standardize the size of wire produced by manufacturers. As a result, the manufacturer has a larger market, and the consumer knows that standard wire sizes will always be available. The table was designed to assist the user in every way possible; it usually includes data such as the cross-sectional area in circular mils, diameter in mils, ohms per 1000 feet at 20°C, and weight per 1000 feet.

The American Wire Gage (AWG) sizes are given in Table 3.2 for solid, round copper wire. A column indicating the maximum allowable current in amperes, as determined by the National Fire Protection Association, has also been included. The most commonly used appear in boldface.

The chosen sizes have an interesting relationship:

***The area is doubled for every drop in 3 gage numbers and increased by a factor of 10 for every drop of 10 gage numbers.***

Examining Eq. (3.1), we note also that *doubling the area cuts the resistance in half, and increasing the area by a factor of 10 decreases the resistance of 1/10 the original*, everything else kept constant.

The actual sizes of some of the gage wires listed in Table 3.2 are shown in Fig. 3.8 with a few of their areas of application. A few examples using Table 3.2 follow.

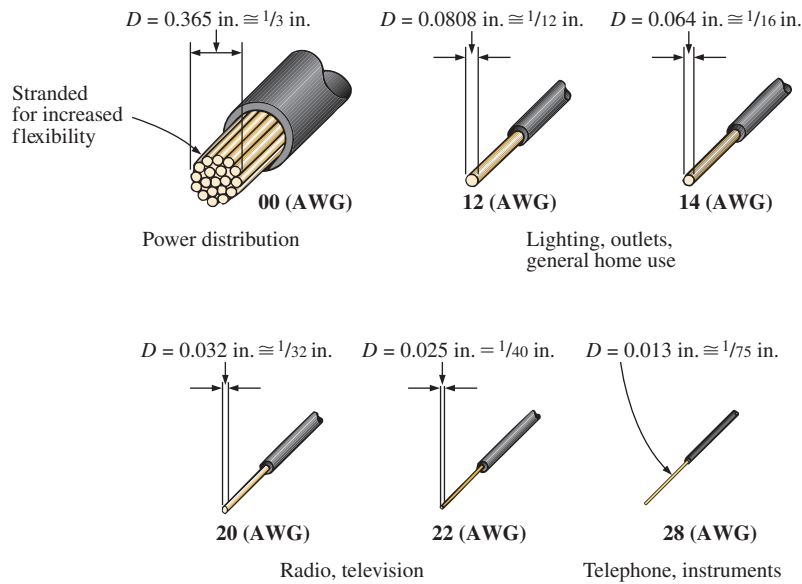

**TABLE 3.2**  
American Wire Gage (AWG) sizes.

	AWG #	Area (CM)	$\Omega/1000$ ft at 20°C	Maximum Allowable Current for RHW Insulation (A)*	
Businesses, Large homes	{ (4/0)	<b>0000</b>	211,600	0.0490	<b>230</b>
	{ (3/0)	<b>000</b>	167,810	0.0618	<b>200</b>
Most new homes	{ (2/0)	<b>00</b>	133,080	0.0780	<b>175</b>
	{ (1/0)	<b>0</b>	105,530	0.0983	<b>150</b>
		<b>1</b>	83,694	0.1240	<b>130</b>
		<b>2</b>	66,373	0.1563	<b>115</b>
		<b>3</b>	52,634	0.1970	<b>100</b>
		<b>4</b>	41,742	0.2485	<b>85</b>
		<b>5</b>	33,102	0.3133	—
Some electrical appliances	{	<b>6</b>	26,250	0.3951	<b>65</b>
	{	<b>7</b>	20,816	0.4982	—
	{	<b>8</b>	16,509	0.6282	<b>50</b>
	{	<b>9</b>	13,094	0.7921	—
	{	<b>10</b>	10,381	0.9989	<b>30</b>
		<b>11</b>	8,234.0	1.260	—
Most house wiring	{	<b>12</b>	6,529.9	1.588	<b>20</b>
	{	<b>13</b>	5,178.4	2.003	—
	{	<b>14</b>	4,106.8	2.525	<b>15</b>
		<b>15</b>	3,256.7	3.184	
		<b>16</b>	2,582.9	4.016	
		<b>17</b>	2,048.2	5.064	
		<b>18</b>	1,624.3	6.385	
		<b>19</b>	1,288.1	8.051	
Electronic projects	{	<b>20</b>	1,021.5	10.15	
	{	<b>21</b>	810.10	12.80	
	{	<b>22</b>	642.40	16.14	
	{	<b>23</b>	509.45	20.36	
	{	<b>24</b>	404.01	25.67	
	{	<b>25</b>	320.40	32.37	
	{	<b>26</b>	254.10	40.81	
	{	<b>27</b>	201.50	51.47	
	{	<b>28</b>	159.79	64.90	
	{	<b>29</b>	126.72	81.83	
		<b>30</b>	100.50	103.2	
		<b>31</b>	79.70	130.1	
As AWG increases area drops	→	<b>32</b>	63.21	164.1	
		<b>33</b>	50.13	206.9	
		<b>34</b>	39.75	260.9	
		<b>35</b>	31.52	329.0	
		<b>36</b>	25.00	414.8	
		<b>37</b>	19.83	523.1	
		<b>38</b>	15.72	659.6	
		<b>39</b>	12.47	831.8	
		<b>40</b>	9.89	1049.0	

As AWG  
increases  
resistance  
increases

\*Not more than three conductors in raceway, cable, or direct burial.

**FIG. 3.8**

Popular AWG sizes and some of their areas of application.

**EXAMPLE 3.4** Find the resistance of 650 ft of #8 copper wire ( $T = 20^\circ\text{C}$ ).

**Solution:** For #8 copper wire (solid),  $\Omega/1000$  ft at  $20^\circ\text{C} = 0.6282 \Omega$ , and

$$650 \text{ ft} \left( \frac{0.6282 \Omega}{1000 \text{ ft}} \right) = \mathbf{0.41 \Omega}$$

**EXAMPLE 3.5** What is the diameter, in inches, of a #12 copper wire?

**Solution:** For #12 copper wire (solid),  $A = 6529.9 \text{ CM}$ , and

$$d_{\text{mils}} = \sqrt{A_{\text{CM}}} = \sqrt{6529.9 \text{ CM}} \cong 80.81 \text{ mils}$$

$$d \cong \mathbf{0.08 \text{ in.}} \text{ (or close to } 1/12 \text{ in.)}$$

**EXAMPLE 3.6** For the system in Fig. 3.9, the total resistance of each power line cannot exceed  $0.025 \Omega$ , and the maximum current to be drawn by the load is 95 A. What gage wire should be used?

**Solution:**

$$R = \rho \frac{l}{A} \Rightarrow A = \rho \frac{l}{R} = \frac{(10.37 \text{ CM}\cdot\Omega/\text{ft})(100 \text{ ft})}{0.025 \Omega} = \mathbf{41,480 \text{ CM}}$$

Using the wire table, we choose the wire with the next largest area, which is #4, to satisfy the resistance requirement. We note, however, that 95 A must flow through the line. This specification requires that #3 wire be used since the #4 wire can carry a maximum current of only 85 A.

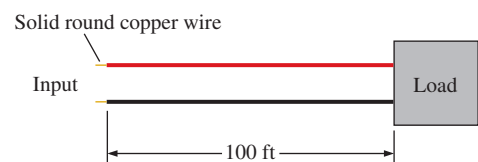

**FIG. 3.9**  
Example 3.6.

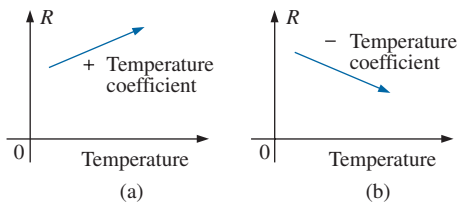
**FIG. 3.10**

Demonstrating the effect of a positive and a negative temperature coefficient on the resistance of a conductor.

### 3.4 TEMPERATURE EFFECTS

Temperature has a significant effect on the resistance of conductors, semiconductors, and insulators.

#### Conductors

Conductors have a generous number of free electrons, and any introduction of thermal energy will have little impact on the total number of free carriers. In fact, the thermal energy only increases the intensity of the random motion of the particles within the material and makes it increasingly difficult for a general drift of electrons in any one direction to be established. The result is that

*for good conductors, an increase in temperature results in an increase in the resistance level. Consequently, conductors have a positive temperature coefficient.*

The plot in Fig. 3.10(a) has a positive temperature coefficient.

#### Semiconductors

In semiconductors, an increase in temperature imparts a measure of thermal energy to the system that results in an increase in the number of free carriers in the material for conduction. The result is that

*for semiconductor materials, an increase in temperature results in a decrease in the resistance level. Consequently, semiconductors have negative temperature coefficients.*

The thermistor and photoconductive cell discussed in Sections 3.12 and 3.13, respectively, are excellent examples of semiconductor devices with negative temperature coefficients. The plot in Fig. 3.10(b) has a negative temperature coefficient.

#### Insulators

*As with semiconductors, an increase in temperature results in a decrease in the resistance of an insulator. The result is a negative temperature coefficient.*

### 3.5 CONDUCTORS AND THE INFERRED ABSOLUTE TEMPERATURE ( $T_i$ )

Fig. 3.11 reveals that for copper (and most other metallic conductors), the resistance increases almost linearly (in a straight-line relationship) with an increase in temperature. Since temperature can have such a pronounced effect on the resistance of a conductor, it is important that we have some method of determining the resistance at any temperature within operating limits. An equation for this purpose can be obtained by approximating the curve in Fig. 3.11 by the straight dashed line that intersects the temperature scale at  $-234.5^\circ\text{C}$ . Although the actual curve extends to **absolute zero** ( $-273.15^\circ\text{C}$ , or 0 K), the straight-line approximation is quite accurate for the normal operating temperature range. At two temperatures  $T_1$  and  $T_2$ , the resistance of copper is  $R_1$  and  $R_2$ ,

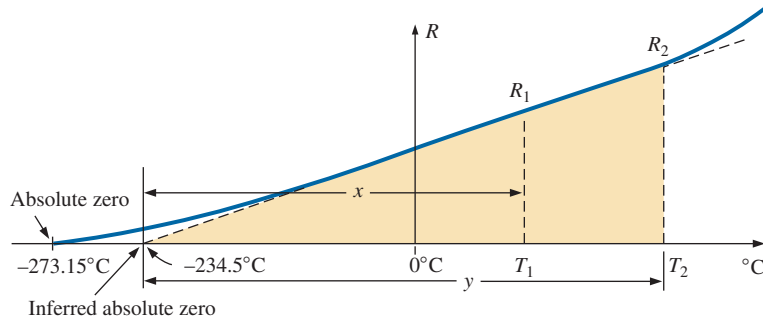
**FIG. 3.11**

*Effect of temperature on the resistance of copper.*

respectively, as indicated on the curve. Using a property of similar triangles, we may develop a mathematical relationship between these values of resistance at different temperatures. Let  $x$  equal the distance from  $-234.5^\circ\text{C}$  to  $T_1$  and  $y$  the distance from  $-234.5^\circ\text{C}$  to  $T_2$ , as shown in Fig. 3.11. From similar triangles,

$$\frac{x}{R_1} = \frac{y}{R_2}$$

or

$$\boxed{\frac{234.5 + T_1}{R_1} = \frac{234.5 + T_2}{R_2}} \quad (3.5)$$

The temperature of  $-234.5^\circ\text{C}$  is called the **inferred absolute temperature** ( $T_i$ ) of copper. For different conducting materials, the intersection of the straight-line approximation occurs at different temperatures. A few typical values are listed in Table 3.3.

The minus sign does not appear with the inferred absolute temperature on either side of Eq. (3.5) because  $x$  and  $y$  are the *distances* from  $-234.5^\circ\text{C}$  to  $T_1$  and  $T_2$ , respectively, and therefore are simply magnitudes. For  $T_1$  and  $T_2$  less than zero,  $x$  and  $y$  are less than  $-234.5^\circ\text{C}$ , and the distances are the differences between the inferred absolute temperature and the temperature of interest.

Eq. (3.5) can easily be adapted to any material by inserting the proper inferred absolute temperature. It may therefore be written as follows:

$$\boxed{\frac{|T_i| + T_1}{R_1} = \frac{|T_i| + T_2}{R_2}} \quad (3.6)$$

where  $|T_i|$  indicates that the inferred absolute temperature of the material involved is inserted as a positive value in the equation. In general, therefore, associate the sign only with  $T_1$  and  $T_2$ .

**EXAMPLE 3.7** If the resistance of a copper wire is  $50\ \Omega$  at  $20^\circ\text{C}$ , what is its resistance at  $100^\circ\text{C}$  (boiling point of water)?

**Solution:** Eq. (3.5):

$$\frac{234.5^\circ\text{C} + 20^\circ\text{C}}{50\ \Omega} = \frac{234.5^\circ\text{C} + 100^\circ\text{C}}{R_2}$$

$$R_2 = \frac{(50\ \Omega)(334.5^\circ\text{C})}{254.5^\circ\text{C}} = \mathbf{65.72\ \Omega}$$

**TABLE 3.3**

*Inferred absolute temperatures ( $T_i$ ).*

Material	$^\circ\text{C}$
Silver	-243
<b>Copper</b>	<b>-234.5</b>
Gold	-274
Aluminum	-236
Tungsten	-204
Nickel	-147
Iron	-162
Nichrome	-2,250
Constantan	-125,000

**EXAMPLE 3.8** If the resistance of a copper wire at freezing ( $0^\circ\text{C}$ ) is  $30\ \Omega$ , what is its resistance at  $-40^\circ\text{C}$ ?

**Solution:** Eq. (3.5):

$$\frac{234.5^\circ\text{C} + 0}{30\ \Omega} = \frac{234.5^\circ\text{C} - 40^\circ\text{C}}{R_2}$$

$$R_2 = \frac{(30\ \Omega)(194.5^\circ\text{C})}{234.5^\circ\text{C}} = \mathbf{24.88\ \Omega}$$

**EXAMPLE 3.9** If the resistance of an aluminum wire at room temperature ( $20^\circ\text{C}$ ) is  $100\ \text{m}\Omega$  (measured by a milliohm meter), at what temperature will its resistance increase to  $120\ \text{m}\Omega$ ?

**Solution:** Eq. (3.5):

$$\frac{236^\circ\text{C} + 20^\circ\text{C}}{100\ \text{m}\Omega} = \frac{236^\circ\text{C} + T_2}{120\ \text{m}\Omega}$$

and

$$T_2 = 120\ \text{m}\Omega \left( \frac{256^\circ\text{C}}{100\ \text{m}\Omega} \right) - 236^\circ\text{C}$$

$$T_2 = \mathbf{71.2^\circ\text{C}}$$

**TABLE 3.4**

Temperature coefficient of resistance for various conductors at  $20^\circ\text{C}$ .

Material	Temperature Coefficient ( $\alpha_{20}$ )
Silver	0.0038
<b>Copper</b>	<b>0.00393</b>
Gold	0.0034
Aluminum	0.00391
Tungsten	0.005
Nickel	0.006
Iron	0.0055
Constantan	0.000008
Nichrome	0.00044

### 3.6 TEMPERATURE COEFFICIENT OF RESISTANCE

There is a second popular equation for calculating the resistance of a conductor at different temperatures. Defining

$$\alpha_{20} = \frac{1}{|T_i| + 20^\circ\text{C}} \quad (\Omega/^\circ\text{C}/\Omega) \quad (3.7)$$

as the **temperature coefficient of resistance** at a temperature of  $20^\circ\text{C}$  and  $R_{20}$  as the resistance of the sample at  $20^\circ\text{C}$ , we determine the resistance  $R_1$  at a temperature  $T_1$  by

$$R_1 = R_{20} [1 + \alpha_{20} (T_1 - 20^\circ\text{C})] \quad (3.8)$$

The values of  $\alpha_{20}$  for different materials have been evaluated, and a few are listed in Table 3.4. Eq. (3.8) can be derived by applying the roles for similar triangles to the plot of Fig. 3.11.

Eq. (3.8) can be written in the following form:

$$\alpha_{20} = \frac{\left( \frac{R_1 - R_{20}}{T_1 - 20^\circ\text{C}} \right)}{R_{20}} = \frac{\Delta R}{R_{20} \Delta T} \quad (3.9)$$

from which the units of  $\Omega/^\circ\text{C}/\Omega$  for  $\alpha_{20}$  are defined.

Since  $\Delta R/\Delta T$  is the slope of the curve in Fig. 3.11, we can conclude that

**the higher the temperature coefficient of resistance for a material, the more sensitive is the resistance level to changes in temperature.**

Referring to Table 3.4, we find that copper is more sensitive to temperature variations than is silver, gold, or aluminum, although the

differences are quite small. The slope defined by  $\alpha_{20}$  for constantan is so small that the curve is almost horizontal.

Since  $R_{20}$  of Eq. (3.8) is the resistance of the conductor at  $20^\circ\text{C}$  and  $T_1 - 20^\circ\text{C}$  is the change in temperature from  $20^\circ\text{C}$ , Eq. (3.8) can be written in the following form:

$$R = \rho \frac{l}{A} [1 + \alpha_{20} \Delta T] \quad (3.10)$$

providing an equation for resistance in terms of all the controlling parameters.

### 3.7 PPM/ $^\circ\text{C}$

For resistors, as for conductors, resistance changes with a change in temperature. The specification is normally provided in parts per million per degree Celsius (**PPM/ $^\circ\text{C}$** ), providing an immediate indication of the sensitivity level of the resistor to temperature. For resistors, a 5000 PPM level is considered high, whereas 20 PPM is quite low. A 1000 PPM/ $^\circ\text{C}$  characteristic reveals that a  $1^\circ$  change in temperature results in a change in resistance equal to 1000 PPM, or  $1000/1,000,000 = 1/1000$  of its nameplate value—not a significant change for most applications. However, a  $10^\circ$  change results in a change equal to  $1/100$  (1%) of its nameplate value, which is becoming significant. The concern, therefore, lies not only with the PPM level but also with the range of expected temperature variation.

In equation form, the change in resistance is given by

$$\Delta R = \frac{R_{\text{nominal}}}{10^6} (\text{PPM})(\Delta T) \quad (3.11)$$

where  $R_{\text{nominal}}$  is the nameplate value of the resistor at room temperature and  $\Delta T$  is the change in temperature from the reference level of  $20^\circ\text{C}$ .

---

**EXAMPLE 3.10** For a 1 k $\Omega$  carbon composition resistor with a PPM of 2500, determine the resistance at  $60^\circ\text{C}$ .

**Solution:**

$$\begin{aligned} \Delta R &= \frac{1000 \Omega}{10^6} (2500)(60^\circ\text{C} - 20^\circ\text{C}) \\ &= 100 \Omega \end{aligned}$$

and

$$\begin{aligned} R &= R_{\text{nominal}} + \Delta R = 1000 \Omega + 100 \Omega \\ &= \mathbf{1100 \Omega} \end{aligned}$$

---

## 3.8 TYPES OF RESISTORS

### Fixed Resistors

Resistors are made in many forms, but all belong in either of two groups: fixed or variable. The most common of the low-wattage, fixed-type resistors is the film resistor shown in Fig. 3.12. It is constructed by depositing a thin layer of resistive material (typically carbon, metal, or metal

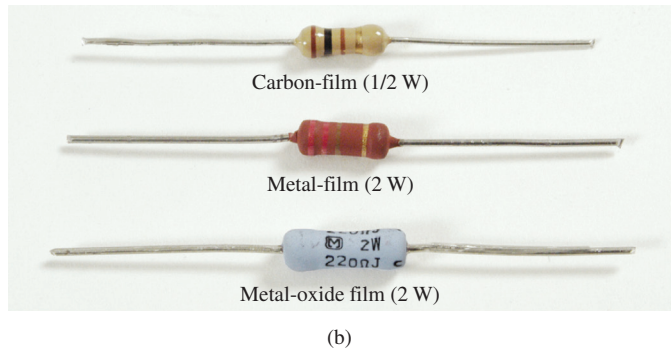
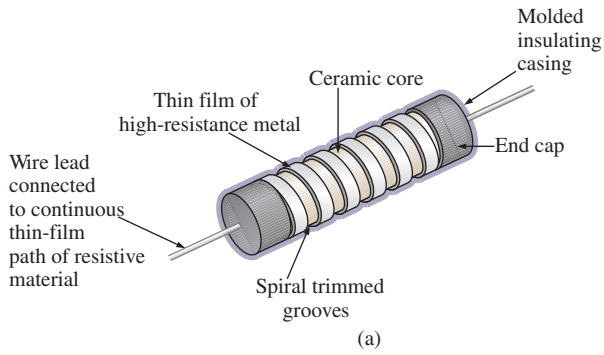

**FIG. 3.12**

*Film resistors: (a) construction; (b) types.*

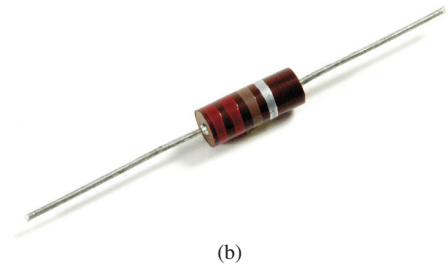
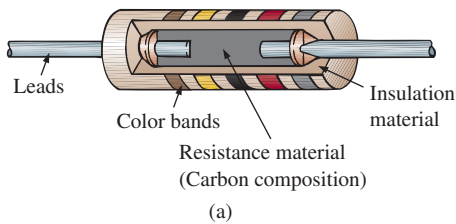

**FIG. 3.13**

*Fixed-composition resistors: (a) construction; (b) appearance.*

oxide) on a ceramic rod. The desired resistance is then obtained by cutting away some of the resistive material in a helical manner to establish a long, continuous band of high-resistance material from one end of the resistor to the other. In general, carbon-film resistors have a beige body and a lower wattage rating. The metal-film resistor is typically a stronger color, such as brick red or dark green, with higher wattage ratings. The metal-oxide resistor is usually a softer pastel color, such as rating powder blue shown in Fig. 3.12(b), and has the highest wattage rating of the three.

When you search through most electronics catalogs or visit a local electronics dealer to purchase resistors, you will find that the most common resistor is the film resistor. In years past, the carbon composition resistor in Fig. 3.13 was the most common, but fewer and fewer companies are manufacturing this variety, with its range of applications reduced to applications in which very high temperatures and inductive effects (Chapter 11) can be a problem. Its resistance is determined by the carbon composition material molded directly to each end of the resistor. The high-resistivity characteristics of carbon ( $\rho = 21,000 \text{ CM-}\Omega/\text{ft}$ ) provide a high-resistance path for the current through the element.

**For a particular style and manufacturer, the size of a resistor increases with the power or wattage rating.**

The concept of power is covered in detail in Chapter 4, but for the moment recognize that increased power ratings are normally associated with the ability to handle higher current and temperature levels. Fig. 3.14 depicts the actual size of thin-film, metal-oxide resistors in the 1/4 W to 5 W rating range. All the resistors in Fig. 3.14 are 1 M $\Omega$ , revealing that

**the size of a resistor does not define its resistance level.**

A variety of other fixed resistors are depicted in Fig. 3.15. The wire-wound resistors of Fig. 3.15(a) are formed by winding a high-resistance wire around a ceramic core. The entire structure is then baked in a ceramic cement to provide a protective covering. Wire-wound resistors are typically used for larger power applications, although they are also available with very small wattage ratings and very high accuracy.

Fig. 3.15(c) and (g) are special types of wire-wound resistors with a low percent tolerance. Note, in particular, the high power ratings for the wire-wound resistors for their relatively small size. Figs. 3.15(b), (d), and (f) are power film resistors that use a thicker layer of film material than used in the variety shown

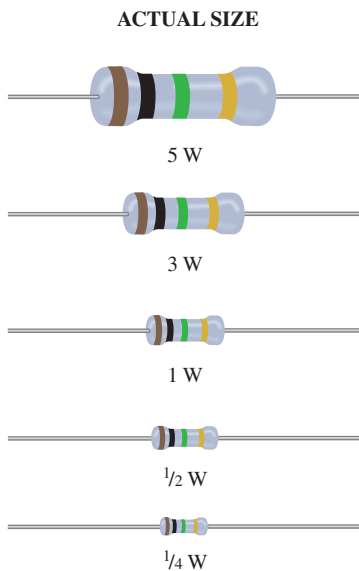

**FIG. 3.14**

*Fixed metal-oxide resistors of different wattage ratings.*

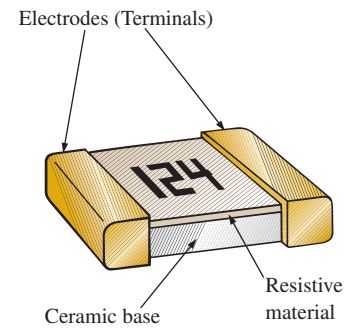
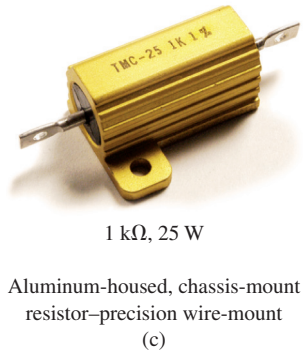
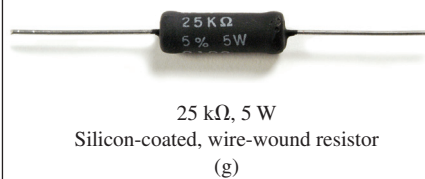
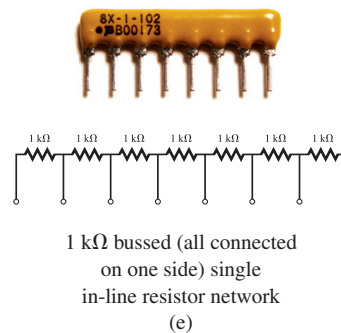
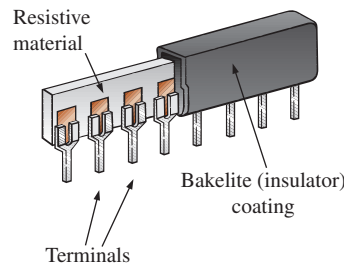
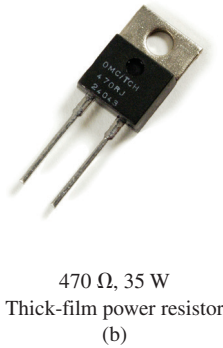
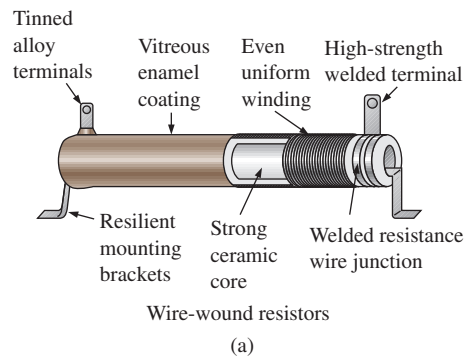
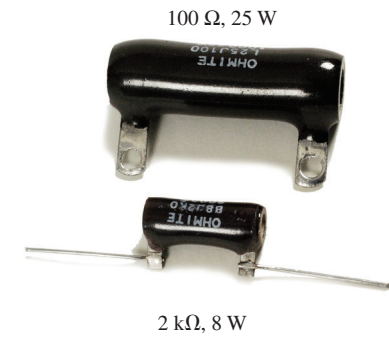

**FIG. 3.15**  
Various types of fixed resistors.

in Fig. 3.12. The chip resistors in Fig. 3.15(f) are used where space is a priority, such as on the surface of circuit board. Units of this type can be less than 1/16 in. in length or width, with thickness as small as 1/30 in., yet they can still handle 0.5 W of power with resistance levels as high as 1000 MΩ—clear evidence that size does not determine the resistance level. The fixed resistor in Fig. 3.15(e) has terminals applied to a layer of resistor material, with the resistance between the terminals a function of the dimensions of the resistive material and the placement of the terminal pads.

## Maximum Voltage Rating

In addition to a wattage rating, every resistor has a maximum voltage rating. Both must be considered with the use of any resistor in any application. In some cases, the maximum voltage rating may seem so high from typical operating voltages that the power rating is the only one of any consequence. Consider, however, a commercially available carbon composition resistor rated for 1 W, a 10% tolerance, and a maximum voltage rating of 500 V available in resistor values from  $2.2\ \Omega$  to  $1\ \text{M}\Omega$ . Keep in mind that the complete line of resistors with this 1 W power rating and maximum voltage rating all have the same size and construction. Internally, of course, the resistive material is altered to provide the desired resistance, but the external appearance is the same. Within this series of resistors, a  $10\ \Omega$  resistor would need only 3.16 V applied across it to reach the 1 W rating. The calculations surrounding this conclusion will be discussed in Chapter 4. Certainly, the 3.16 V is magnitudes smaller than the rated voltage of 500 V and it may never be necessary to worry about this rating. However, we would also find that if we were using a  $250\ \text{k}\Omega$  resistor from the package of resistors, it would require 500 V to reach the 1 W power dissipation level. In fact any resistor between  $250\ \text{k}\Omega$  and  $1\ \text{M}\Omega$  would require more than the rated 500 V to dissipate a power level of 1 W. For the  $1\ \text{M}\Omega$  resistor, the power dissipated at 500 V is only  $\frac{1}{4}$  W. The result, therefore, is that the applied voltage is a very important factor because it is related to the maximum power dissipation capabilities of the resistor. Furthermore, if the applied voltage exceeds the maximum rated value, the resistive qualities of the resistor may deteriorate, high surface currents may develop, arcing may occur, or the resistor itself may open or cause a short circuit.

## Variable Resistors

Variable resistors, as the name implies, have a terminal resistance that can be varied by turning a dial, knob, screw, or whatever seems appropriate for the application. They can have two or three terminals, but most have three terminals. If the two- or three-terminal device is used as a variable resistor, it is usually referred to as a **rheostat**. If the three-terminal device is used for controlling potential levels, it is then commonly called a **potentiometer**. Even though a three-terminal device can be used as a rheostat or a potentiometer (depending on how it is connected), it is typically called a *potentiometer* when listed in trade magazines or requested for a particular application.

The symbol for a three-terminal potentiometer appears in Fig. 3.16(a). When used as a variable resistor (or rheostat), it can be hooked up in one of two ways, as shown in Figs. 3.16(b) and (c). In Fig. 3.16(b), points *a* and

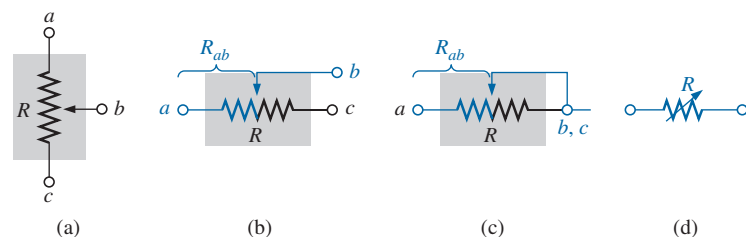

**FIG. 3.16**

Potentiometer: (a) symbol; (b) and (c) rheostat connections; (d) rheostat symbol.

$b$  are hooked up to the circuit, and the remaining terminal is left hanging. The resistance introduced is determined by that portion of the resistive element between points  $a$  and  $b$ . In Fig. 3.16(c), the resistance is again between points  $a$  and  $b$ , but now the remaining resistance is “shorted-out” (effect removed) by the connection from  $b$  to  $c$ . The universally accepted symbol for a rheostat appears in Fig. 3.16(d).

Most potentiometers have three terminals in the relative positions shown in Fig. 3.17. The knob, dial, or screw in the center of the housing controls the motion of a contact that can move along the resistive element connected between the outer two terminals. The contact is connected to the center terminal, establishing a resistance from movable contact to each outer terminal.

The internal construction of the potentiometer is provided in Fig. 3.17(b). The resistive element is typically carbon or wire-wound. The center leg ( $b$ ) is connected to the moveable arm (in blue) through the Philips screw without making contact with the moveable arm. Terminal  $c$  is connected directly to the bottom right of the resistive material without making contact with the moveable arm. The resistance between terminals  $c$  and  $b$  is then the major part of the resistive material as shown in Figs. 3.17(b) and (c). Contact is made at the point indicated by the dot in the moveable arm. The resistance between terminals  $b$  and  $a$  is then the smaller portion of the resistive material as shown in both figures. The contact point has the full range of the resistive material to control the level of resistance between the three points of the potentiometer.

**The resistance between the outside terminals  $a$  and  $c$  in Fig. 3.17 is always fixed at the full rated value of the potentiometer, regardless of the position of the wiper arm  $b$ .**

In other words, the resistance between terminals  $a$  and  $c$  in Fig. 3.18(a) for a  $1\text{ M}\Omega$  potentiometer will always be  $1\text{ M}\Omega$ , no matter how we turn the control element and move the contact. In Fig. 3.18(a), the center contact is not part of the network configuration.

**The resistance between the wiper arm and either outside terminal can be varied from a minimum of  $0\ \Omega$  to a maximum value equal to the full rated value of the potentiometer.**

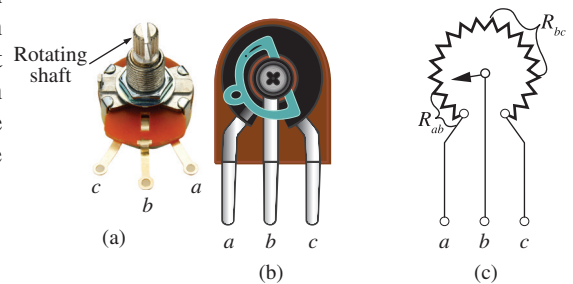

**FIG. 3.17**  
Potentiometer: (a) external, (b) internal, (c) circuit equivalent.  
(Don Johnson Photo)

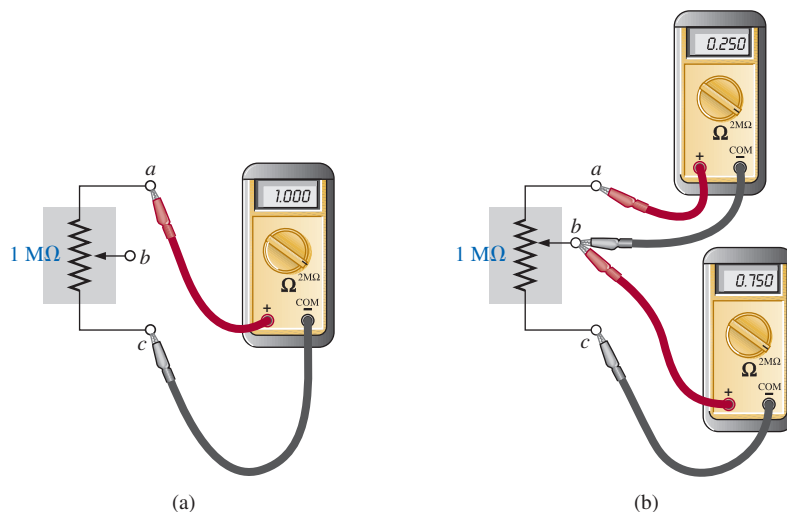

**FIG. 3.18**  
Resistance components of a potentiometer: (a) between outside terminals; (b) between wiper arm and each outside terminal.

In Fig. 3.18(b), the wiper arm has been placed 1/4 of the way down from point  $a$  to point  $c$ . The resulting resistance between points  $a$  and  $b$  will therefore be 1/4 of the total, or 250 k $\Omega$  (for a 1 M $\Omega$  potentiometer), and the resistance between  $b$  and  $c$  will be 3/4 of the total, or 750 k $\Omega$ .

**The sum of the resistances between the wiper arm and each outside terminal equals the full rated resistance of the potentiometer.**

This is demonstrated in Fig. 3.18(b), where 250 k $\Omega$  + 750 k $\Omega$  = 1 M $\Omega$ . Specifically,

$$R_{ac} = R_{ab} + R_{bc} \quad (3.12)$$

Therefore, as the resistance from the wiper arm to one outside contact increases, the resistance between the wiper arm and the other outside terminal must decrease accordingly. For example, if  $R_{ab}$  of a 1 k $\Omega$  potentiometer is 200  $\Omega$ , then the resistance  $R_{bc}$  must be 800  $\Omega$ . If  $R_{ab}$  is further decreased to 50  $\Omega$ , then  $R_{bc}$  must increase to 950  $\Omega$ , and so on.

The molded carbon composition potentiometer is typically applied in networks with smaller power demands, and it ranges in size from 20  $\Omega$  to 22 M $\Omega$  (maximum values). A miniature trimmer (less than 1/4 in. in diameter) appears in Fig. 3.19(a), and a variety of potentiometers that use a cermet resistive material appear in Fig. 3.19(b). The contact point of the three-point wire-wound resistor in Fig. 3.19(c) can be moved to set the resistance between the three terminals.

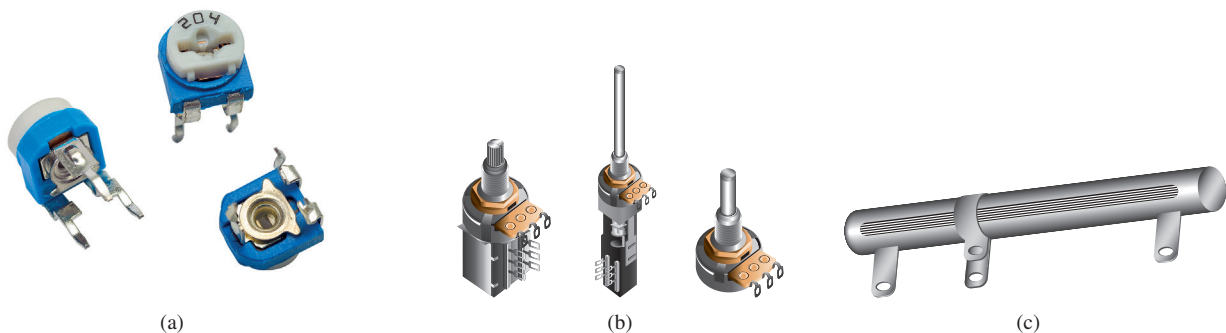

**FIG. 3.19**

Variable resistors: (a) 4 mm ( $\approx 5/32$  in.) trimmer; (b) conductive plastic and cermet elements; (c) three-point wire-wound resistor.  
(a) vlabo/Shutterstock

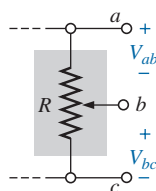

**FIG. 3.20**

Potentiometer control of voltage levels.

When the device is used as a potentiometer, the connections are as shown in Fig. 3.20. It can be used to control the level of  $V_{ab}$ ,  $V_{bc}$ , or both, depending on the application. Additional discussion of the potentiometer in a loaded situation can be found in later chapters.

### 3.9 COLOR CODING AND STANDARD RESISTOR VALUES

A wide variety of resistors, fixed or variable, are large enough to have their resistance in ohms printed on the casing. Some, however, are too small to have numbers printed on them, so a system of **color coding** is used. For the thin-film resistor, four, five, or six bands may be used. The four-band scheme is described. Later in this section, the purpose of the fifth and sixth bands will be described.

For the four-band scheme, the bands are *always read from the end that has a band closest to it*, as shown in Fig. 3.21. The bands are numbered as shown for reference in the discussion to follow.

**The first two bands represent the first and second digits, respectively.**

They are the actual first two numbers that define the numerical value of the resistor.

**The third band determines the power-of-ten multiplier for the first two digits (actually the number of zeros that follow the second digit for resistors greater than 10 Ω).**

**The fourth band is the manufacturer's tolerance, which is an indication of the precision by which the resistor was made.**

If the fourth band is omitted, the tolerance is assumed to be  $\pm 20\%$ .

The number corresponding to each color is defined in Fig. 3.22. The fourth band will be either  $\pm 5\%$  or  $\pm 10\%$  as defined by gold and silver, respectively. To remember which color goes with which percent, simply remember that  $\pm 5\%$  resistors cost more and gold is more valuable than silver.

Remembering which color goes with each digit takes a bit of practice. In general, the colors start with the very dark shades and move toward the lighter shades. The best way to memorize is to simply repeat over and over that red is 2, yellow is 4, and so on. Simply practice with a friend or a fellow student, and you will learn most of the colors in short order.



**FIG. 3.21**  
Color coding for fixed resistors.

Number	Color
0	Black
1	Brown
2	Red
3	Orange
4	Yellow
5	Green
6	Blue
7	Violet
8	Gray
9	White

$\pm 5\%$ (0.1 multiplier if 3rd band)	Gold
$\pm 10\%$ (0.01 multiplier if 3rd band)	Silver

**FIG. 3.22**  
Color coding.

**EXAMPLE 3.11** Find the value of the resistor in Fig. 3.23.

**Solution:** Reading from the band closest to the left edge, we find that the first two colors of brown and red represent the numbers 1 and 2, respectively. The third band is orange, representing the number 3 for the power of the multiplier as follows:

$$12 \times 10^3 \Omega$$

resulting in a value of 12 kΩ. As indicated above, if 12 kΩ is written as 12,000 Ω, the third band reveals the number of zeros that follow the first two digits.

Now for the fourth band of gold, representing a tolerance of  $\pm 5\%$ : To find the range into which the manufacturer has guaranteed the resistor will fall, first convert the 5% to a decimal number by moving the decimal point two places to the left:

$$5\% \Rightarrow 0.05$$

Then multiply the resistor value by this decimal number:

$$0.05(12 \text{ k}\Omega) = 600 \Omega$$

Finally, add the resulting number to the resistor value to determine the maximum value, and subtract the number to find the minimum value. That is,

$$\text{Maximum} = 12,000 \Omega + 600 \Omega = 12.6 \text{ k}\Omega$$

$$\text{Minimum} = 12,000 \Omega - 600 \Omega = 11.4 \text{ k}\Omega$$

$$\text{Range} = \mathbf{11.4 \text{ k}\Omega \text{ to } 12.6 \text{ k}\Omega}$$



**FIG. 3.23**  
Example 3.11.

The result is that the manufacturer has guaranteed with the 5% gold band that the resistor will fall in the range just determined. In other words, the manufacturer does not guarantee that the resistor will be exactly 12 k $\Omega$ , but rather that it will fall in a range as defined above.

Using the above procedure, the smallest resistor that can be labeled with the color code is 10  $\Omega$ . However,

**the range can be extended to include resistors from 0.1  $\Omega$  to 10  $\Omega$  by simply using gold as a multiplier color (third band) to represent 0.1 and using silver to represent 0.01.**

This is demonstrated in the next example.



**FIG. 3.24**  
Example 3.12.

**EXAMPLE 3.12** Find the value of the resistor in Fig. 3.24.

**Solution:** The first two colors are gray and red, representing the numbers 8 and 2, respectively. The third color is gold, representing a multiplier of 0.1. Using the multiplier, we obtain a resistance of

$$(0.1)(82 \Omega) = 8.2 \Omega$$

The fourth band is silver, representing a tolerance of  $\pm 10\%$ . Converting to a decimal number and multiplying through yields

$$10\% = 0.10 \quad \text{and} \quad (0.1)(8.2 \Omega) = 0.82 \Omega$$

$$\text{Maximum} = 8.2 \Omega + 0.82 \Omega = 9.02 \Omega$$

$$\text{Minimum} = 8.2 \Omega - 0.82 \Omega = 7.38 \Omega$$

so that **Range = 7.38  $\Omega$  to 9.02  $\Omega$**

Although it will take some time to learn the numbers associated with each color, it is certainly encouraging to become aware that

**the same color scheme to represent numbers is used for all the important elements of electrical circuits.**

Later on, you will find that the numerical value associated with each color is the same for capacitors and inductors. Therefore, once learned, the scheme has repeated areas of application.

Some manufacturers prefer to use a **five-band color code**. In such cases, as shown in the top portion of Fig. 3.25, three digits are provided before the multiplier. The fifth band remains the tolerance indicator. If the manufacturer decides to include the temperature coefficient, a sixth band will appear as shown in the lower portion of Fig. 3.25, with the color indicating the PPM level.

For four, five, or six bands, if the tolerance is less than 5%, the following colors are used to reflect the % tolerances:

**brown =  $\pm 1\%$ , red =  $\pm 2\%$ , green =  $\pm 0.5\%$ , blue =  $\pm 0.25\%$ , and violet =  $\pm 0.1\%$ .**

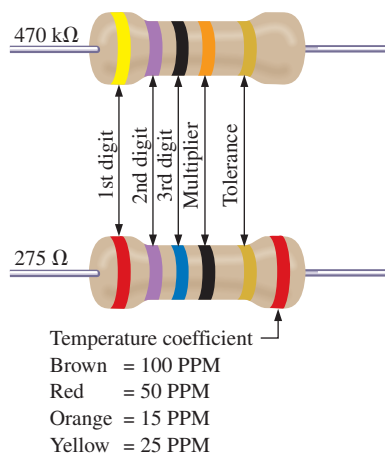

**FIG. 3.25**  
Five-band color coding for fixed resistors.

You might expect that resistors would be available for a full range of values such as 10  $\Omega$ , 20  $\Omega$ , 30  $\Omega$ , 40  $\Omega$ , 50  $\Omega$ , and so on. However, this is not the case, with some typical commercial values as 27  $\Omega$ , 56  $\Omega$ , and 68  $\Omega$ . There is a reason for the chosen values, which is best demonstrated by examining the list of standard values of commercially available resistors in Table 3.5. The values in boldface are the most common and typically available with 5%, 10%, and 20% tolerances.

**TABLE 3.5**
*Standard values of commercially available resistors.*

Ohms ( $\Omega$ )		Kilohms ( $k\Omega$ )		Megohms ( $M\Omega$ )				
<b>0.10</b>	<b>1.0</b>	<b>10</b>	<b>100</b>	<b>1000</b>	<b>10</b>	<b>100</b>	<b>1.0</b>	<b>10.0</b>
0.11	1.1	11	110	1100	11	110	1.1	11.0
<b>0.12</b>	<b>1.2</b>	<b>12</b>	<b>120</b>	<b>1200</b>	<b>12</b>	<b>120</b>	<b>1.2</b>	<b>12.0</b>
0.13	1.3	13	130	1300	13	130	1.3	13.0
<b>0.15</b>	<b>1.5</b>	<b>15</b>	<b>150</b>	<b>1500</b>	<b>15</b>	<b>150</b>	<b>1.5</b>	<b>15.0</b>
0.16	1.6	16	160	1600	16	160	1.6	16.0
<b>0.18</b>	<b>1.8</b>	<b>18</b>	<b>180</b>	<b>1800</b>	<b>18</b>	<b>180</b>	<b>1.8</b>	<b>18.0</b>
0.20	2.0	20	200	2000	20	200	2.0	20.0
<b>0.22</b>	<b>2.2</b>	<b>22</b>	<b>220</b>	<b>2200</b>	<b>22</b>	<b>220</b>	<b>2.2</b>	<b>22.0</b>
0.24	2.4	24	240	2400	24	240	2.4	
<b>0.27</b>	<b>2.7</b>	<b>27</b>	<b>270</b>	<b>2700</b>	<b>27</b>	<b>270</b>	<b>2.7</b>	
0.30	3.0	30	300	3000	30	300	3.0	
<b>0.33</b>	<b>3.3</b>	<b>33</b>	<b>330</b>	<b>3300</b>	<b>33</b>	<b>330</b>	<b>3.3</b>	
0.36	3.6	36	360	3600	36	360	3.6	
<b>0.39</b>	<b>3.9</b>	<b>39</b>	<b>390</b>	<b>3900</b>	<b>39</b>	<b>390</b>	<b>3.9</b>	
0.43	4.3	43	430	4300	43	430	4.3	
<b>0.47</b>	<b>4.7</b>	<b>47</b>	<b>470</b>	<b>4700</b>	<b>47</b>	<b>470</b>	<b>4.7</b>	
0.51	5.1	51	510	5100	51	510	5.1	
<b>0.56</b>	<b>5.6</b>	<b>56</b>	<b>560</b>	<b>5600</b>	<b>56</b>	<b>560</b>	<b>5.6</b>	
0.62	6.2	62	620	6200	62	620	6.2	
<b>0.68</b>	<b>6.8</b>	<b>68</b>	<b>680</b>	<b>6800</b>	<b>68</b>	<b>680</b>	<b>6.8</b>	
0.75	7.5	75	750	7500	75	750	7.5	
<b>0.82</b>	<b>8.2</b>	<b>82</b>	<b>820</b>	<b>8200</b>	<b>82</b>	<b>820</b>	<b>8.2</b>	
0.91	9.1	91	910	9100	91	910	9.1	

Examining the impact of the tolerance level will help explain the choice of numbers for the commercial values. Take the sequence  $47\ \Omega - 68\ \Omega - 100\ \Omega$ , which are all available with 20% tolerances. In Fig. 3.26(a), the tolerance band for each has been determined and plotted on a single axis. Note that with this tolerance (which is all that the manufacturer will guarantee), the full range of resistor values is available from

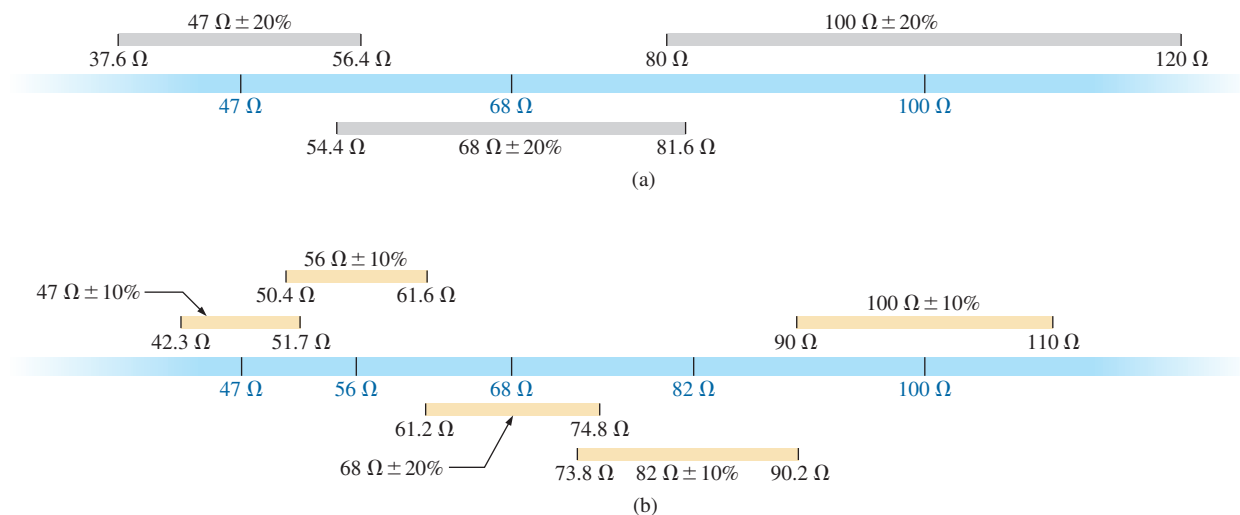
**FIG. 3.26**
*Guaranteeing the full range of resistor values for the given tolerance: (a) 20%; (b) 10%.*



37.6  $\Omega$  to 120  $\Omega$ . In other words, the manufacturer is guaranteeing the full range, using the tolerances to fill in the gaps. Dropping to the 10% level introduces the 56  $\Omega$  and 82  $\Omega$  resistors to fill in the gaps, as shown in Fig. 3.26(b). Dropping to the 5% level would require additional resistor values to fill in the gaps. In total, therefore, the resistor values were chosen to ensure that the full range was covered, as determined by the tolerances employed. Of course, if a specific value is desired but is not one of the standard values, combinations of standard values often result in a total resistance very close to the desired level. If this approach is still not satisfactory, a potentiometer can be set to the exact value and then inserted in the network.

Throughout the text, you will find that many of the resistor values are not standard values. This was done to reduce the mathematical complexity, which might interfere with the learning process. In the problem sections, however, standard values are frequently used to ensure that you start to become familiar with the commercial values available.

### 3.10 SURFACE MOUNT RESISTORS

In general, surface mount resistors, such as appearing in Fig. 3.15(f), are marked in three ways: color coding, three symbols, and two symbols.

The **color coding** is the same as just described earlier in this section for through-hole resistors.

The **three-symbol** approach uses three digits. The first two define the first two digits of the value; the last digit defines the power of the power-of-ten multiplier.

For instance:

$$820 \text{ is } 82 \times 10^0 \Omega = \mathbf{82} \Omega$$

$$222 \text{ is } 22 \times 10^2 \Omega = 2200 \Omega = \mathbf{2.2} \text{ k}\Omega$$

$$010 \text{ is } 1 \times 10^0 \Omega = \mathbf{1} \Omega$$

The **two-symbol** marking uses a letter followed by a number. The letter defines the value as in the following list. Note that all the numbers of the commercially available list of Table 3.5 are included.

<b>A</b> = 1.0	<b>B</b> = 1.1	<b>C</b> = 1.2	<b>D</b> = 1.3
<b>E</b> = 1.5	<b>F</b> = 1.6	<b>G</b> = 1.8	<b>H</b> = 2
<b>J</b> = 2.2	<b>K</b> = 2.4	<b>L</b> = 2.7	<b>M</b> = 3
<b>N</b> = 3.3	<b>P</b> = 3.6	<b>Q</b> = 3.9	<b>R</b> = 4.3
<b>S</b> = 4.7	<b>T</b> = 5.1	<b>U</b> = 5.6	<b>V</b> = 6.2
<b>W</b> = 6.8	<b>X</b> = 7.5	<b>Y</b> = 8.2	<b>Z</b> = 9.1

The second symbol is the power of the power-of-ten multiplier.  
For example,

$$C3 = 1.2 \times 10^3 \Omega = \mathbf{1.2} \text{ k}\Omega$$

$$T0 = 5.1 \times 10^0 \Omega = \mathbf{5.1} \Omega$$

$$Z1 = 9.1 \times 10^1 \Omega = \mathbf{91} \Omega$$

Additional symbols may precede or follow the codes and may differ depending on the manufacturer. These may provide information on the internal resistance structure, power rating, surface material, tapping, and tolerance.

### 3.11 CONDUCTANCE

By finding the reciprocal of the resistance of a material, we have a measure of how well the material conducts electricity. The quantity is called **conductance**, has the symbol  $G$ , and is measured in *siemens* (S) (note Fig. 3.27). In equation form, conductance is

$$G = \frac{1}{R} \quad (\text{siemens, S}) \quad (3.13)$$

A resistance of  $1 \text{ M}\Omega$  is equivalent to a conductance of  $10^{-6} \text{ S}$ , and a resistance of  $10 \text{ }\Omega$  is equivalent to a conductance of  $10^{-1} \text{ S}$ . The larger the conductance, therefore, the less is the resistance and the greater is the conductivity.

In equation form, the conductance is determined by

$$G = \frac{A}{\rho l} \quad (\text{S}) \quad (3.14)$$

indicating that increasing the area or decreasing either the length or the resistivity increases the conductance.

#### EXAMPLE 3.13

- Determine the conductance of a  $1 \text{ }\Omega$ , a  $50 \text{ k}\Omega$ , and a  $10 \text{ M}\Omega$  resistor.
- How does the conductance level change with increase in resistance?

**Solution:** Eq. (3.13):

$$\text{a. } 1 \text{ }\Omega : G = \frac{1}{R} = \frac{1}{1 \text{ }\Omega} = \mathbf{1 \text{ S}}$$

$$50 \text{ k}\Omega : G = \frac{1}{R} = \frac{1}{50 \text{ k}\Omega} = \frac{1}{50 \times 10^3 \text{ }\Omega} = 0.02 \times 10^{-3} \text{ S} = \mathbf{0.02 \text{ mS}}$$

$$10 \text{ M}\Omega : G = \frac{1}{R} = \frac{1}{10 \text{ M}\Omega} = \frac{1}{10 \times 10^6 \text{ }\Omega} = 0.1 \times 10^{-6} \text{ S} = \mathbf{0.1 \text{ }\mu\text{S}}$$

- The conductance level decreases rapidly with significant increase in resistance levels.

**EXAMPLE 3.14** What is the relative increase or decrease in conductivity of a conductor if the area is reduced by 30% and the length is increased by 40%? The resistivity is fixed.

**Solution:** Eq. (3.14):

$$G_i = \frac{1}{R_i} = \frac{1}{\frac{\rho_i l_i}{A_i}} = \frac{A_i}{\rho_i l_i}$$

with the subscript  $i$  for the initial value. Using the subscript  $n$  for the new value, we obtain

$$G_n = \frac{A_n}{\rho_n l_n} = \frac{0.70 A_i}{\rho_i (1.4 l_i)} = \frac{0.70}{1.4} \frac{A_i}{\rho_i l_i} = \frac{0.70}{1.4} G_i$$

and  $G_n = \mathbf{0.5 G_i}$

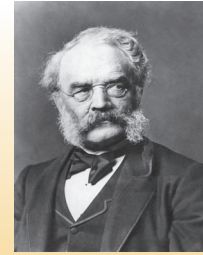

**FIG. 3.27**  
*Werner von Siemens.*  
INTERFOTO/Alamy Stock Photo

**German** (Lenthe, Berlin)  
(1816–92)

**Electrical Engineer**  
**Telegraph Manufacturer,**  
Siemens & Halske AG

Developed an *electroplating process* during a brief stay in prison for acting as a second in a duel between fellow officers of the Prussian army. Inspired by the electronic telegraph invented by Sir Charles Wheatstone in 1817, he improved on the design and with the help of his brother Carl proceeded to lay cable across the Mediterranean and from Europe to India. His inventions included the first *self-excited generator*, which depended on the *residual magnetism* of its electromagnet rather than an inefficient permanent magnet. In 1888 he was raised to the rank of nobility with the addition of *von* to his name. The current firm of Siemens AG has manufacturing outlets in some 35 countries and sales offices in some 125 countries.

### 3.12 OHMMETERS

The **ohmmeter** is an instrument used to perform the following tasks and several other useful functions:

1. *Measure the resistance of individual or combined elements.*
2. *Detect open-circuit (high-resistance) and short-circuit (low-resistance) situations.*
3. *Check the continuity of network connections and identify wires of a multilead cable.*
4. *Test some semiconductor (electronic) devices.*

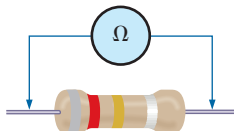

**FIG. 3.28**

*Measuring the resistance of a single element.*

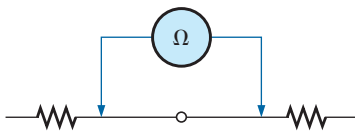

**FIG. 3.29**

*Checking the continuity of a connection.*

For most applications, the ohmmeters used most frequently are the ohmmeter section of a VOM or DMM. The details of the internal circuitry and the method of using the meter will be left primarily for a laboratory exercise. In general, however, the resistance of a resistor can be measured by simply connecting the two leads of the meter across the resistor, as shown in Fig. 3.28. There is no need to be concerned about which lead goes on which end; the result is the same in either case since resistors offer the same resistance to the flow of charge (current) in either direction. If the VOM is used, a switch must be set to the proper resistance range, and a nonlinear scale (usually the top scale of the meter) must be properly read to obtain the resistance value. The DMM also requires choosing the best scale setting for the resistance to be measured, but the result appears as a numerical display, with the proper placement of the decimal point determined by the chosen scale. When measuring the resistance of a single resistor, it is usually best to remove the resistor from the network before making the measurement. If this is difficult or impossible, at least one end of the resistor must not be connected to the network, otherwise the reading may include the effects of the other elements of the system.

If the two leads of the meter are touching in the ohmmeter mode, the resulting resistance is zero. A connection can be checked as shown in Fig. 3.29 by simply hooking up the meter to either side of the connection. If the resistance is zero, the connection is secure. If it is other than zero, the connection could be weak; if it is infinite, there is no connection at all.

If one wire of a harness or ribbon cable is known, a second can be found as shown in Fig. 3.30. Simply connect the end of the known lead to the end of any other lead. When the ohmmeter indicates zero ohms (or very low resistance), the second lead has been identified. The above procedure can also be used to determine the first known lead by simply connecting the meter to any wire at one end and then touching all the leads at the other end until a zero ohm indication is obtained. Ribbon cables are typically used to electrically interconnect multiple printed circuit board (PCB) functions.

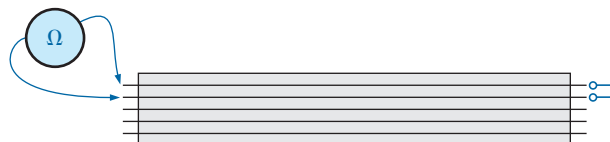

**FIG. 3.30**

*Identifying the leads of a multilead ribbon cable.*

Preliminary measurements of the condition of some electronic devices such as the diode and the transistor can be made using the ohmmeter. The meter can also be used to identify the terminals of such devices.

One important note about the use of any ohmmeter:

**Never hook up an ohmmeter to a live circuit!**

The reading will be meaningless, and you may damage the instrument. The ohmmeter section of any meter is designed to pass a small sensing current through the resistance to be measured. A large external current could damage the movement and would certainly throw off the calibration of the instrument. In addition:

**Never store a VOM or a DMM in the resistance mode.**

If the two leads of the meter touch, the small sensing current could drain the internal battery. VOMs should be stored with the selector switch on the highest voltage range, and the selector switch of DMMs should be in the off position.

### 3.13 RESISTANCE: METRIC UNITS

The design of resistive elements for various areas of application, including thin-film resistors and integrated circuits, uses metric units for the quantities of Eq. (3.1) introduced in Section 3.2. In SI units, the resistivity would be measured in ohm-meters, the area in square meters, and the length in meters. However, the meter is generally too large a unit of measure for most applications, and so the centimeter is usually employed. The resulting dimensions for Eq. (3.1) are therefore

$\rho$ :	ohm-centimeters
$l$ :	centimeters
$A$ :	square centimeters

The units for  $\rho$  can be derived from

$$\rho = \frac{RA}{l} = \frac{\Omega\text{-cm}^2}{\text{cm}} = \Omega\text{-cm}$$

The resistivity of a material is actually the resistance of a sample such as that appearing in Fig. 3.31. Table 3.6 provides a list of values of  $\rho$  in ohm-centimeters. Note that the area now is expressed in square centimeters, which can be determined using the basic equation  $A = \pi d^2/4$ , eliminating the need to work with circular mils, the special unit of measure associated with circular wires.

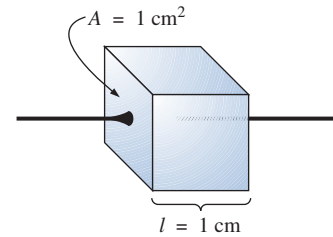

**FIG. 3.31**  
Defining  $\rho$  in ohm-centimeters.

**TABLE 3.6**  
Resistivity ( $r$ ) of various materials.

Material	$\Omega\text{-cm}$
Silver	$1.645 \times 10^{-6}$
<b>Copper</b>	<b><math>1.723 \times 10^{-6}</math></b>
Gold	$2.443 \times 10^{-6}$
Aluminum	$2.825 \times 10^{-6}$
Tungsten	$5.485 \times 10^{-6}$
Nickel	$7.811 \times 10^{-6}$
Iron	$12.299 \times 10^{-6}$
Tantalum	$15.54 \times 10^{-6}$
Nichrome	$99.72 \times 10^{-6}$
Tin oxide	$250 \times 10^{-6}$
Carbon	$3500 \times 10^{-6}$

**EXAMPLE 3.15** Determine the resistance of 100 ft of #28 copper telephone wire if the diameter is 0.0126 in.

**Solution:** Unit conversions:

$$l = 100 \text{ ft} \left( \frac{12 \text{ in.}}{1 \text{ ft}} \right) \left( \frac{2.54 \text{ cm}}{1 \text{ in.}} \right) = 3048 \text{ cm}$$

$$d = 0.0126 \text{ in.} \left( \frac{2.54 \text{ cm}}{1 \text{ in.}} \right) = 0.032 \text{ cm}$$

Therefore,

$$A = \frac{\pi d^2}{4} = \frac{(3.1416)(0.032 \text{ cm})^2}{4} = 8.04 \times 10^{-4} \text{ cm}^2$$

$$R = \rho \frac{l}{A} = \frac{(1.723 \times 10^{-6} \Omega\text{-cm})(3048 \text{ cm})}{8.04 \times 10^{-4} \text{ cm}^2} \cong 6.5 \Omega$$

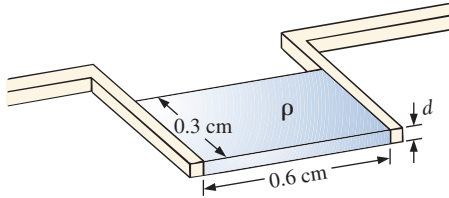

**FIG. 3.32**  
Thin-film resistor. Example 3.16.

Using the units for circular wires and Table 3.2 for the area of a #28 wire, we find

$$R = \rho \frac{l}{A} = \frac{(10.37 \text{ CM-}\Omega/\text{ft})(100 \text{ ft})}{159.79 \text{ CM}} \cong 6.5 \Omega$$

**EXAMPLE 3.16** Determine the resistance of the thin-film resistor in Fig. 3.32 if the **sheet resistance**  $R_s$  (defined by  $R_s = \rho/d$ ) is  $100 \Omega$ .

**Solution:** For deposited materials of the same thickness, the sheet resistance factor is usually employed in the design of thin-film resistors.

Eq. (3.1) can be written

$$R = \rho \frac{l}{A} = \rho \frac{l}{dw} = \left(\frac{\rho}{d}\right) \left(\frac{l}{w}\right) = R_s \frac{l}{w}$$

where  $l$  is the length of the sample and  $w$  is the width. Substituting into the above equation yields

$$R = R_s \frac{l}{w} = \frac{(100 \Omega)(0.6 \text{ cm})}{0.3 \text{ cm}} = 200 \Omega$$

as one might expect since  $l = 2w$ .

The conversion factor between resistivity in circular mil-ohms per foot and ohm-centimeters is the following:

$$\rho(\Omega\text{-cm}) = (1.662 \times 10^{-7}) \times (\text{value in CM-}\Omega/\text{ft})$$

For example, for copper,  $\rho = 10.37 \text{ CM-}\Omega/\text{ft}$ :

$$\begin{aligned} \rho(\Omega\text{-cm}) &= 1.662 \times 10^{-7} (10.37 \text{ CM-}\Omega/\text{ft}) \\ &= 1.723 \times 10^{-6} \Omega\text{-cm} \end{aligned}$$

as indicated in Table 3.6.

The resistivity in an integrated circuit design is typically in ohm-centimeter units, although tables often provide  $\rho$  in ohm-meters or microhm-centimeters. Using the conversion technique of Chapter 1, we find that the conversion factor between ohm-centimeters and ohm-meters is the following:

$$1.723 \times 10^{-6} \Omega\text{-cm} \left[ \frac{1 \text{ m}}{100 \text{ cm}} \right] = \frac{1}{100} [1.723 \times 10^{-6}] \Omega\text{-m}$$

or the value in ohm-meters is 1/100 the value in ohm-centimeters, and

$$\rho(\Omega\text{-m}) = \left(\frac{1}{100}\right) \times (\text{value in } \Omega\text{-cm}) \quad (3.15)$$

Similarly,

$$\rho(\mu\Omega\text{-cm}) = (10^6) \times (\text{value in } \Omega\text{-cm}) \quad (3.16)$$

For comparison purposes, typical values of  $\rho$  in ohm-centimeters for conductors, semiconductors, and insulators are provided in Table 3.7.

In particular, note the power-of-ten difference between conductors and insulators ( $10^{21}$ )—a difference of huge proportions. There is a significant difference in levels of  $\rho$  for the list of semiconductors, but the power-of-ten difference between the conductor and insulator levels is at least  $10^6$  for each of the semiconductors listed.

**TABLE 3.7**  
Comparing levels of  $\rho$  in  $\Omega$ -cm.

Conductor ( $\Omega$ -cm)	Semiconductor ( $\Omega$ -cm)	Insulator ( $\Omega$ -cm)
Copper $1.723 \times 10^{-6}$	Ge 50	In general: $10^{15}$
	Si $200 \times 10^3$	
	GaAs $70 \times 10^6$	

### 3.14 THE FOURTH ELEMENT—THE MEMRISTOR

In May 2008, researchers at Hewlett Packard Laboratories led by Dr. Stanley Williams had an amazing announcement—the discovery of the “missing” link in basic electronic circuit theory called a **memristor (memory resistor)**, shown in Fig. 3.33. Up to this point the basic passive elements of circuit theory were the resistor, the capacitor, and the inductor, with the last two to be introduced later in this text. The presence of this fourth element was postulated in a seminal 1971 paper in the *IEEE Transactions on Circuit Theory* by Leon Chua of the University of California at Berkeley. However, it was not until this announcement that the device was actually constructed and found to function as predicted. Many attempts were made to build a memristor through the years, but it was not until work was done at the nanometer scale that success was obtained. It turns out that the smaller the structure, the more prominent is the *memristance* response. The level of memristance at the nanometer scale is a million times stronger than at the micrometer scale and is almost undetectable at the millimeter scale. However, this property can work to the advantage of current integrated circuit (IC) designs that are already in the nanometer range.

The four basic circuit quantities of charge, current, voltage, and magnetic flux can be related in six ways. Three relations derive from the basic elements of the resistor, the capacitor, and the inductor. The resistor provides a direct relationship between current and voltage, the capacitor provides a relationship between charge and voltage, and the inductor provides a relationship between current and magnetic flux. That leaves the relationship between the magnetic flux and the charge moving through an element. Chua sought a device that would define the relationship between magnetic flux and charge similar to that between the voltage and current of a resistor.

In general, Chua was looking for a device whose resistance would be a function of how much charge has passed through it. In Chapter 11 the relationship between the movement of charge and the surrounding magnetic field will be described in keeping with the need to find a device relating charge flow and the surrounding magnetic field.

**The memristor is a device whose resistance increases with increase in the flow of charge in one direction and decreases as the flow of charge decreases in the reverse direction. Furthermore, and vastly important, it maintains its new resistance level when the excitation has been removed.**

This behavior in the nanometer range was discovered using the semiconductor titanium dioxide ( $\text{TiO}_2$ ), which is a highly resistive material but can be doped with other materials to make it very conductive. In this material, the dopants move in response to an applied electric field and drift in the direction of the resulting current. Starting out with a memristor with dopants only one side and pure  $\text{TiO}_2$  on the other, one can apply a biasing voltage to establish a current in the memristor. The

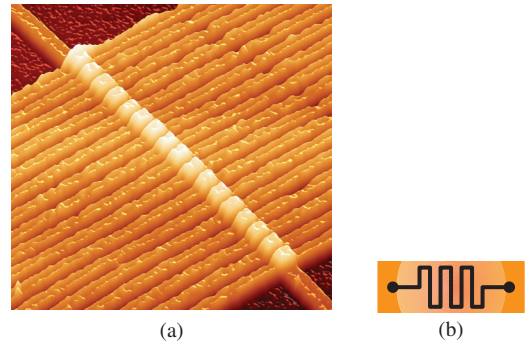

**FIG. 3.33**  
(a) An image of a circuit with 17 memristors captured by an atomic force microscope. Each memristor is composed of two layers of titanium dioxide sandwiched between a lower common wire and its own upper wire. As a voltage is applied across a memristor, the small signal resistance of one of the titanium dioxide layers is changed, which in turn is used as a method to register data. (b) Symbol.  
[(a) Copyright © 2014 Hewlett-Packard Development Company, L.P. Reproduced with Permission.]