



ADVANCES IN CLINICAL CHEMISTRY

Volume 15

Oscar Bodansky &
A. L. Latner

ADVANCES IN CLINICAL CHEMISTRY

VOLUME 15

This Page Intentionally Left Blank

Advances in
**CLINICAL
CHEMISTRY**

Edited by

OSCAR BODANSKY

*Sloan-Kettering Institute for Cancer Research
New York, New York*

A. L. LATNER

*Department of Clinical Biochemistry, The University of
Newcastle upon Tyne, The Royal Victoria Infirmary,
Newcastle upon Tyne, England*

VOLUME 15 • 1972



**ACADEMIC PRESS
NEW YORK AND LONDON**

COPYRIGHT © 1972, BY ACADEMIC PRESS, INC.

ALL RIGHTS RESERVED.

NO PART OF THIS PUBLICATION MAY BE REPRODUCED OR TRANSMITTED IN ANY FORM OR BY ANY MEANS, ELECTRONIC OR MECHANICAL, INCLUDING PHOTOCOPY, RECORDING, OR ANY INFORMATION STORAGE AND RETRIEVAL SYSTEM, WITHOUT PERMISSION IN WRITING FROM THE PUBLISHER.

ACADEMIC PRESS, INC.

111 Fifth Avenue, New York, New York 10003

United Kingdom Edition published by
ACADEMIC PRESS, INC. (LONDON) LTD.
24/28 Oval Road, London NW1

LIBRARY OF CONGRESS CATALOG CARD NUMBER: 58-12341

PRINTED IN THE UNITED STATES OF AMERICA

CONTENTS

LIST OF CONTRIBUTORS	vii
CORBET PAGE STEWART	ix
PREFACE	xiii

Automated, High-Resolution Analyses for the Clinical Laboratory by Liquid Column Chromatography

CHARLES D. SCOTT

1. Introduction	1
2. Analytical Systems	3
3. Description of Analyzers	4
4. Experimental Results and Applications	25
5. Utility and Future of High-Resolution Analytical Systems	36
References	39

Acid Phosphatase

OSCAR BODANSKY

1. Introduction	44
2. Methods of Determination of Acid Phosphatase Activity	45
3. Acid Phosphatases from Different Tissues: Purification, Isoenzymes, and Properties	52
4. Intracellular Distribution of Acid Phosphatase	77
5. Polymorphism of Acid Phosphatase in Human Erythrocytes	92
6. Alterations of Serum Acid Phosphatase Activity in Disease	99
7. Lysosomal Disease and Acid Phosphatase Activity	132
References	136

Normal and Abnormal Human Hemoglobins

TITUS H. J. HUISMAN

1. Introduction	150
2. Normal Human Hemoglobins	150
3. Hemoglobin Abnormalities	168
4. Thalassemia	188
5. The Genetic Heterogeneity of Fetal Hemoglobin (With Walter A. Schroeder)	200
6. Methodology (With Ruth N. Wrightstone)	213
References	224

The Endocrine Response to Trauma

IVAN D. A. JOHNSON

1. Introduction	255
2. Adrenocortical Secretion	256

3. Anterior Pituitary	261
4. Posterior Pituitary	265
5. Insulin and Carbohydrate Metabolism	267
6. Catecholamines	269
7. Kidney Hormones	271
8. Thyroid	272
9. Activation of the Endocrine Response	275
10. Adrenocortical Insufficiency	277
11. Summary	279
References	280

Instrumentation in Clinical Chemistry

PETER M. G. BROUGHTON AND JOHN B. DAWSON

1. Introduction	288
2. General Principles of Instrumentation	289
3. Atomic Spectroscopy	304
4. Ultraviolet and Visible Spectrophotometers	320
5. Fluorimeters and Phosphorimeters	327
6. Infrared and Raman Spectroscopy	331
7. Micro- and Radiowave Spectroscopy	337
8. Nucleonics and X-Ray Methods	339
9. Particle Spectrometry	345
10. Chromatography	347
11. Electrophoresis	355
12. Electrometric Methods	356
13. Conclusions	363
References	364
 AUTHOR INDEX	 381
 SUBJECT INDEX	 408
 CONTENTS OF PREVIOUS VOLUMES	 413

LIST OF CONTRIBUTORS

Numbers in parentheses indicate the pages on which the authors' contributions begin.

OSCAR BODANSKY (43), *Sloan-Kettering Institute for Cancer Research, New York, New York*

PETER M. G. BROUGHTON (287), *University Department of Chemical Pathology, The General Infirmary, Leeds, England*

JOHN B. DAWSON (287), *University Department of Medical Physics, The General Infirmary, Leeds, England*

TITUS H. J. HUISMAN (149), *Laboratory of Protein Chemistry, Department of Cell and Molecular Biology, Medical College of Georgia, and Veterans Administration Hospital, Augusta, Georgia*

IVAN D. A. JOHNSTON (225), *Department of Surgery, University of Newcastle upon Tyne, England*

WALTER A. SCHROEDER (200), *California Institute of Technology, Pasadena, California*

CHARLES D. SCOTT (1), *Biochemical Technology Division, Oak Ridge National Laboratory, Oak Ridge, Tennessee*

RUTH N. WRIGHTSTONE (213), *Department of Medical Technology, Medical College of Georgia, Augusta, Georgia*



CORBET PAGE STEWART

OBITUARY

CORBET PAGE STEWART

1897-1972

The death of Corbet Page Stewart on April 5, 1972 preceded by just a few days his 75th birthday. He was, along with the late Harry H. Sobotka, coeditor of *Advances in Clinical Chemistry* from Volume 1 in 1958 through to Volume 9, and continued in this capacity, along with Oscar Bodansky, until Volume 13 in 1970. There is no doubt that he played a very large part not only in the actual birth of this Serial Publication, but also in the standard which it has achieved. He brought with him an exceptionally wide knowledge of clinical chemistry, as well as an extraordinary facility for decisions regarding those people who were authorities in the advancing aspects of the subject. His facility as an editor was widely recognized. It was matched only by his ability to get on very well with colleagues and to render harmonious many situations which might otherwise have proved disruptive.

Corbet Page Stewart, affectionately known as "C.P." to his friends and colleagues, was born on the 14th April, 1897, at Willington, County Durham, where his father was the schoolmaster. He was educated at Bishop Auckland and subsequently at Armstrong College, Newcastle upon Tyne, which was, at that time, part of the University of Durham. He graduated in chemistry in 1920; his studies had, however, been interrupted by military service in the First World War. He subsequently studied for his doctorate under Professor George Barger in the Department of Medical Chemistry, University of Edinburgh, and proceeded to the Ph.D., his first doctorate, in 1925. He had held a Beit Memorial Fellowship from 1923 to 1925 and during this period worked each summer with Professor Gowland Hopkins at Cambridge. It was inevitable that, because of his publications and his international reputation, he proceeded to a second doctorate, the degree of D.Sc.

In 1926, he took up the appointments of Biochemist to the Royal Infirmary, Edinburgh, and Lecturer in the Department of Biochemistry of the University of Edinburgh. Such a joint appointment was, at the time, an unusual phenomenon, for his predecessor at the Royal Infirmary, Charles Harington, did not, in fact, hold a University appointment. Dr. Stewart gradually became a full-time clinical chemist and taught medical as well as science students.

From 1926 until the Second World War, he developed the biochemical service at the Royal Infirmary. At the same time he evolved undergraduate courses in medical biochemistry. In 1940, he was appointed Honorary Director of the Edinburgh and South-East Scotland Blood Transfusion Service and later became its Chairman. During the Second World War he was a member of the Medical Research Council's Blood Transfusion Research Committee and Adviser to the Polish Red Cross Institute of Blood Transfusion. As a result of this latter work, and his role in relation to the Polish Medical School, he received the honor of Polonia Restituta from the Polish Government-in-exile.

From 1942 to 1945, Dr. Stewart was a member of the Committee of the Biochemical Society.

In 1946, the University of Edinburgh established a Department of Clinical Chemistry with Dr. Stewart as Head and its first Reader. In 1948, with the onset of the National Health Service, he was made honorary consultant in clinical chemistry to the South-East Scotland Regional Hospital Board—an unusual event for a scientist who did not hold a medical degree. It was due recognition, however, of the remarkable knowledge of medicine in an individual without formal training in the subject. He was also appointed to the Board of Management of the Edinburgh Central Hospitals, and between 1956 and 1964 was Chairman of that Board as well as of the Boards of the Sick Childrens' Hospital and the geriatric hospital, Queensberry House.

In 1960, his Department at the Royal Infirmary, Edinburgh, moved into a new building, which was at that time acknowledged to be, and still is, one of the finest laboratories in the world. I visited it on a number of occasions and was more impressed each time. The move coincided with the 4th International Congress of Clinical Chemistry held in Edinburgh, with Dr. Stewart as Chairman of the Organising Committee. Three years later, in 1963, he served in a similar capacity at the International Congress on Nutrition, also held in Edinburgh. He was a member of the Organizing Committee of the Annual Colloquia on Protides of the Biological Fluids held at Bruges, and played an important role in relation to the West European Symposia on Clinical Chemistry.

Dr. Stewart was a leader in the development of clinical biochemistry in the United Kingdom. He was a founder member of the Association of Clinical Biochemists and became a member of its Council, subsequently its Chairman and eventually its President. I was, at that time, Chairman and together we drew up the first real Constitution of the Association. I well remember the wisdom he displayed both in this respect and later on in regard to the advice he gave me when I succeeded him as President.

His published work covered many fields and included diverse subjects such as the chemistry of amino acids and peptides, especially glutathione; mineral metabolism, with special reference to calcium; melanin pigment metabolism; ascorbic acid metabolism; metabolic aspects of cardiac muscle; and analytical techniques for lipids, nitrogenous compounds, and cortisol. He was an extraordinarily meticulous analyst who, from the first, maintained that the standards of technique in the service laboratory should be the same as those required for research purposes. He maintained that the fulfillment of clinical chemistry demanded equal collaboration between physician and chemist. The function of the latter was not to usurp that of the former but to assist the clinician by helping to shed light on the nature of an illness.

In addition to his large output of scientific papers, Dr. Stewart, was coauthor with D. Dunlop of *Clinical Chemistry in Practical Medicine* (E. & S. Livingstone Ltd., New York, 1st ed., 1931; 6th ed., 1962); with A. Stolman he was coeditor of *Toxicology Mechanisms and Analytical Methods* (Academic Press, New York, Vol. 1, 1960; Vol. 2, 1961). He was a member of the Editorial Board of *Clinica Chimica Acta* from the time of the foundation of that journal. He became Editor-in-Chief in 1960 and held this appointment until just before his death.

Stewart had many interests and talents outside the laboratory. As a youth he represented the University of Durham at cricket and hockey, and was a keen badminton player and an enthusiastic hill walker. In addition to being an excellent photographer with a keen eye for good composition, he had a fine collection of United States stamps, and was so interested in church architecture and history that he would make lengthy detours to add to the list of cathedrals and abbeys he had visited and about which he had an enormous store of knowledge.

There are very few men who will be remembered by their friends and colleagues with such deep respect and affection. Come wind, rain, or snow in any part of the world "C.P." would appear at meetings without hat or overcoat but with the inevitable cheroot or cigarette and a welcoming smile on his face. He obviously enjoyed life to the full and led a full life long into his retirement. In spite of his great ability, he was a very modest man, who achieved the highest pinnacle of success without blowing his own trumpet. He was always helpful to others, no matter how junior.

In 1963, Dr. Stewart received the Ames Award of the American Association of Clinical Chemists and in 1972, just before his death, he learned that he was to be the second recipient of the Distinguished Clinical Chemist Award of the International Federation of Clinical Chemistry. The award, presented after he had died, was received by his son, in the

presence of Queen Margrethe II of Denmark, at the opening ceremony of the 8th International Congress on Clinical Chemistry at Copenhagen on June 18, 1972. Those of us present will never forget this very moving ceremony and the intense applause when the award was received.

A. L. LATNER

PREFACE

In this volume of the *Advances*, the Editors have continued to follow the original dual aim of the series: the description of reliable diagnostic and prognostic procedures and the elucidation of fundamental biochemical abnormalities that underlie disease. As is true for so many other branches of science, clinical chemistry is experiencing an ever-accelerating pace of technological advance and accrual of new information. It is incumbent upon the clinical chemist to be aware of these changes, and to choose the particular technology and acquire that information which best suits the needs of his particular situation.

In their review on instrumentation in clinical chemistry, Broughton and Dawson have treated most comprehensively the principles underlying the use of various types of instruments in clinical chemistry, envisioning the incorporation of such instruments into automated and computerized systems. Scott has discussed a relatively new type of technology, namely, automated, high resolution analyses by liquid column chromatography. He describes procedures by means of which a large number of the constituents of a sample mixture are separated and quantified. Huisman reviewed the subject of normal and abnormal hemoglobins in these *Advances* in 1963, but the past nine years has seen such progress in various aspects of this important field that it was deemed advisable to bring the subject up to date. Although the enzyme acid phosphatase was discovered in 1925 and claimed considerable attention in the thirties and forties, no review of the entire subject has heretofore appeared in these *Advances*. Bodansky has considered not only the generally appreciated role of this enzyme in diagnosis of cancer of the prostate, but has also reviewed more recent applications in other diseases, in genetics, and in general biology. The metabolic responses following surgery or other physical trauma have been of substantial interest for several years and Johnston has now reviewed in some detail the endocrine aspects of these responses.

As in the past, it is a great pleasure to thank our contributors and publisher for their excellent cooperation in making this volume possible.

OSCAR BODANSKY
A. L. LATNER

This Page Intentionally Left Blank

AUTOMATED, HIGH-RESOLUTION ANALYSES FOR THE CLINICAL LABORATORY BY LIQUID COLUMN CHROMATOGRAPHY

Charles D. Scott

Biochemical Technology Division, Oak Ridge National Laboratory¹
Oak Ridge, Tennessee

1. Introduction.....	1
2. Analytical Systems.....	3
3. Description of Analyzers.....	4
3.1. General System Description.....	4
3.2. Separation Systems.....	4
3.3. Eluent Delivery.....	8
3.4. Generation of the Eluent Concentration Gradient.....	9
3.5. Sample Introduction.....	10
3.6. Column Monitor.....	10
3.7. Data Reduction.....	11
3.8. UV-Analyzer.....	11
3.9. Carbohydrate Analyzer.....	16
3.10. Ninhydrin-Positive Compound Analyzer.....	18
3.11. Organic Acid Analyzer.....	22
4. Experimental Results and Applications.....	25
4.1. Chromatographic Results.....	25
4.2. Identification of Separated Constituents.....	27
4.3. Normal Values.....	32
4.4. Differences in Pathological States and During Drug Intake.....	35
5. Utility and Future of High-Resolution Analytical Systems.....	36
5.1. Data Processing.....	37
5.2. Clinical Significance.....	37
5.3. Economics of High-Resolution Analyses.....	37
5.4. Screening Laboratories.....	39
5.5. Other Uses.....	39
References.....	39

1. Introduction

Many analytical methods used in the clinical laboratory today result in the analysis of a single constituent or of a single group of constituents in a physiological sample mixture. In most of these analytical procedures, an attempt is made to quantify the constituent without isolating it from the complex mixture. A great deal of developmental effort has been directed toward mechanizing many of these methods and, in some cases, in combining several analyses into a single, complex, automated instrumental array that requires a minimum of operator time. Although this

¹Operated for the U. S. Atomic Energy Commission by Union Carbide Corporation.

developmental work has been extremely important to the clinical laboratory from the standpoint of economics, recent research in the medical sciences will probably lead to even more drastic changes in the clinical laboratory in the near future.

It is now apparent that many pathological states will ultimately be defined, studied, and treated on the molecular level. There is a considerable body of information that suggests that the levels of chemical constituents in various body fluids can be used to help indicate bodily function and malfunction. This is not a new concept for the clinical laboratory, but the number of these potential "chemical indicators" has been expanded to several hundred. For example, in a recent bibliography (K1) on urinary constituents, the literature for a three-year period has over 3000 citations to over 700 molecular constituents, many of which could have pathological significance.

Quantitative methods for analyzing for large numbers of the individual constituents of body fluids have frequently involved several steps and excessive operator time. As a result, such complex analyses have been relegated to the research laboratory. It would be extremely difficult and expensive for the clinical laboratory to use these methods on a routine basis, even if they could be entirely automated. However, new high-resolution analytical systems that are capable of automatically analyzing for many of the individual constituents of a physiological sample may be useful in the clinical laboratory for such an in-depth analysis.

The term "high-resolution analysis" has been chosen to describe an analysis in which a large number of all the constituents of a sample mixture are separated and quantified. Thus, high-resolution analytical techniques have two very necessary components: (1) a means of separating the individual components; and (2) a means of detecting and quantifying the separated components. In general, the separation techniques that have proved most satisfactory have been some form of chromatography or electrophoresis, and quantification has been achieved primarily by photometric monitoring for liquid systems and flame ionization for gaseous systems.

Relatively few truly automated, high-resolution analytical systems are now used in the clinical laboratory. For this presentation, I have arbitrarily chosen only those systems that use column chromatography for separation. This choice is based not only on the ability of these systems to separate literally hundreds of the molecular constituents in a physiological fluid but also because they are directly amenable to a high degree of automation. Obviously, this latter point is extremely important for any future development in the clinical laboratory. Further, only liquid chromatography will be discussed here since there has recently

been an excellent review of the use of gas chromatography in the clinical laboratory (S10).

It is difficult to establish the time, places, and pertinent investigators involved in developing high-resolution analytical systems based on liquid chromatography since this technology has been evolving for many years. Yesterday's high-resolution systems are now considered very low-resolution systems indeed. Certainly the early work of Cohn in separation of nucleic acid derivatives by ion-exchange chromatography (C2) was important, as was the development of an automated analytical system for amino acids by Moore and Stein (M1). Hamilton showed that literally hundreds of ninhydrin-positive compounds in urine could be separated and quantified by a modified amino acid analyzer (H3), and Anderson and others followed through on some of Cohn's work to automate the analyses of complex biological fluids in a single system (A1, S1).

There are at present many investigators involved in the general area of high-resolution analysis for the clinical laboratory. Many recent contributions in this field can be found in the proceedings of the annual symposium series on "High-Resolution Analyses and Advanced Analytical Concepts for the Clinical Laboratory" (S4, S6, S8).

2. Analytical Systems

Although the concentrations of the constituents of all types of body fluids represent potentially useful diagnostic information, analysis of the most complex body fluid, urine, presents the most ambitious challenge. One of the most severe tests for the utility of a high-resolution system is its usefulness in analyzing for the constituents of urine. This body fluid has long been neglected in the clinical laboratory. The four analytical systems that will be considered here are at least potentially useful for urine analysis as well as for the other less complex body fluids. They are primarily used for the analysis of the low-molecular-weight (less than 1000) constituents.

Two of these systems, an analyzer for the UV-absorbing constituents (UV-analyzer) and one for carbohydrates, will be discussed in some detail. Two others, one for ninhydrin-positive compounds (amino acids and related compounds) and an analyzer for organic acids, will be introduced as systems that have great potential but which have not been fully developed as yet. These four analytical systems certainly do not represent all the concepts for the use of liquid chromatography in body fluids analysis; however, they are systems that have been used at least to some degree in clinical and medical research laboratories.

The UV- and carbohydrate analyzers were specifically developed to

be used for analyzing body fluids, and prototype systems of each analyzer are now being used at several laboratories. On the other hand, the ninhydrin-positive and organic acid analyzers were not originally developed to be used for complex body fluids, but rather for much simpler mixtures, e.g., protein hydrolyzates. As a result, these two systems have not been fully exploited for body fluids analyses, particularly for urine analysis, although preliminary work indicates that they may have great utility. Thus, the latter two systems will not be discussed in as much detail as the UV- and carbohydrate analyzers.

3. Description of Analyzers

Up to this point in time, high-resolution liquid chromatography requires the use of very small sorption particles packed in relatively long columns. This results in the necessity of operating with relatively high column inlet pressures to force the eluent through the column at a reasonable rate. This requirement of high-pressure operation is the major difference between high-resolution systems and the more conventional liquid chromatography. Much of the following discussion will emphasize the high pressure requirements.

3.1. GENERAL SYSTEM DESCRIPTION

Automated liquid chromatographs contain the following major components: (a) the separation section, which consists of a closed tubular column packed with small particles of the solid sorbent or support material; (b) an eluent storage and, in some cases, an eluent gradient preparation section; (c) an eluent delivery system equipped to deliver the eluent to and force it through the separation column; (d) a means for introducing the sample to the column; and (e) a means for detecting and quantifying the separated constituents in the column eluate (see Fig. 1). Automated data acquisition and processing may also be used.

The requirements of high-pressure operation affect the design and operation of the eluent delivery, sample introduction, and separation systems. Many of those involved in developing high-resolution analytical systems for body fluids have made very significant contributions to high-pressure liquid chromatography technology.

3.2. SEPARATION SYSTEMS

The most important component of the liquid chromatograph is the separation system. Recent advances in liquid chromatography have included the development of many new types of sorption media that have made high-resolution separations possible.

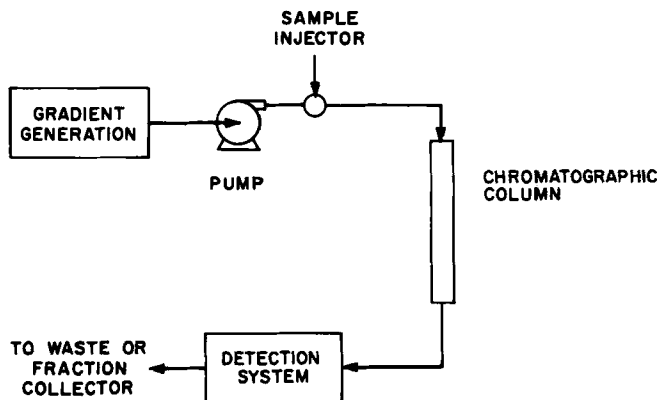

FIG. 1. Liquid column chromatography.

3.2.1. *Separation Media*

The aim in recent developments has been to produce media in which the solid-phase mass transport resistances are reduced. A reduction in these resistances will allow the chromatographic system to operate closer to equilibrium conditions, and should result in faster and more effective separations. All the systems under consideration here achieve high resolution by using relatively small particles (down to about $10\ \mu$ diameter) in the stationary sorption phase in chromatographic columns up to about 150 cm long. The small particles are used to reduce the solid-phase diffusional effects, and the relatively long columns are necessary to provide a sufficient number of separation stages to achieve the high resolution.

3.2.2. *Pressure Drop*

The combination of small particles and long columns contributes to high operating pressures. The effects of column and operating parameters on the pressure drop of liquid-chromatography columns designed to operate at pressures less than about 100 psi can essentially be disregarded since design problems are minimal; however, these effects become very important in high-pressure chromatography (greater than 1000 psi). For a particular type of sorption medium, the major parameters that influence the pressure drop across an ion exchange column are: particle diameter, flow rate, column length, and fluid properties such as density and viscosity. These effects have not been thoroughly studied for small particles; however, previous data (H2) and some of the author's recent work have shown that the pressure drop across a packed column is inversely dependent on the square of the mean diameter of

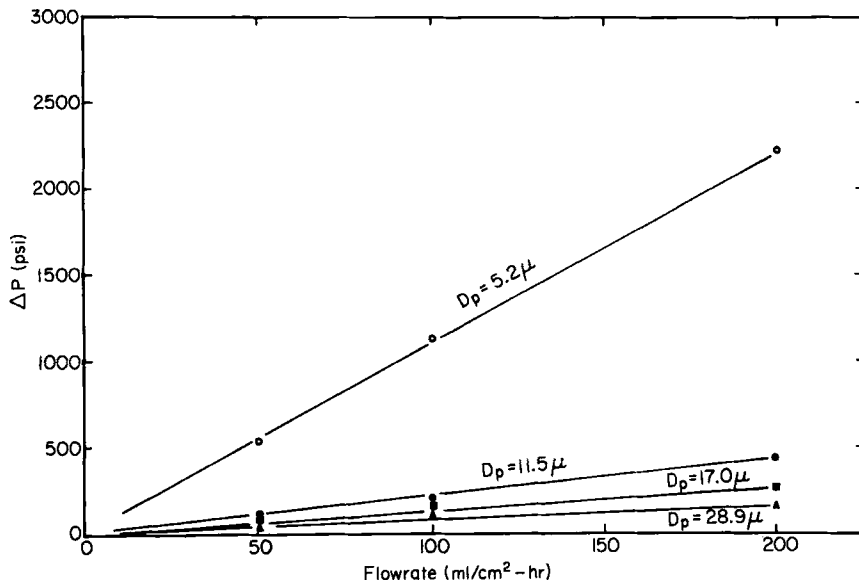

FIG. 2. Pressure drop across ion exchange resin columns as a function of flow rate for resins of different particle size. Operating conditions: 40°C; column, 0.62 × 100 cm, stainless steel; resin, Dowex 1 × -8.

ion exchange resin particles and linearly dependent on the linear velocity of the liquid phase and the length of the column (Fig. 2).

3.2.3. Columns

Metal columns, which can be easily fabricated from seamless metal tubing, can be used for high-pressure techniques. Conventional compression tubing fittings can be used for the fluid entrance and exit and for holding a porous metal support for the fixed bed (Fig. 3). Although the use of precision-bore tubing may be slightly more advantageous, good results have been obtained with common seamless tubing. Some glass columns operable to about 1000 psi are available and have been used in early models of the systems under consideration.

3.2.4. Column Geometry

The geometry of a chromatographic column has a significant effect on the resolution that is achieved. As the length of a column is increased, the separation of two components becomes more efficient; however, the width of the peaks is also increased. The diameter of the column should not have a great effect on resolution (assuming that comparable flow velocities and a proportionally scaled sample size are used) as long as

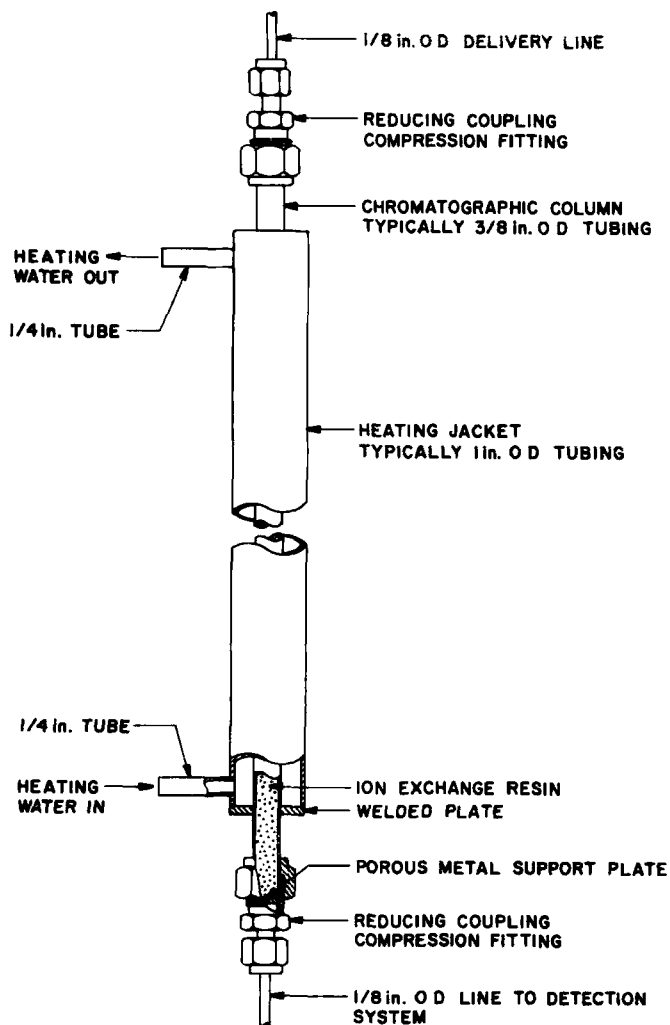

**MATERIAL: TYPE 316 STAINLESS
STEEL**

FIG. 3. High-pressure chromatographic column fabricated from stainless steel tubing. From Scott (S12) copyright © 1968 *Clinical Chemistry*.

the column is sufficiently small to prevent radial variations in fluid properties but not small enough to require a sample of such limited volume that the separated solutes cannot be detected by the column monitoring system. Column diameters in the range of 0.15 to 0.60 cm